

MP

RÉSEAU
ON
GPL

RACCORD À BRASER SUR CUIVRE POUR TUBE PE

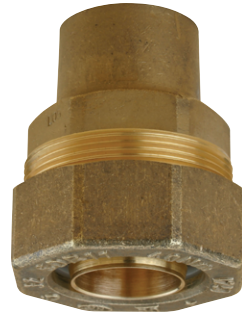
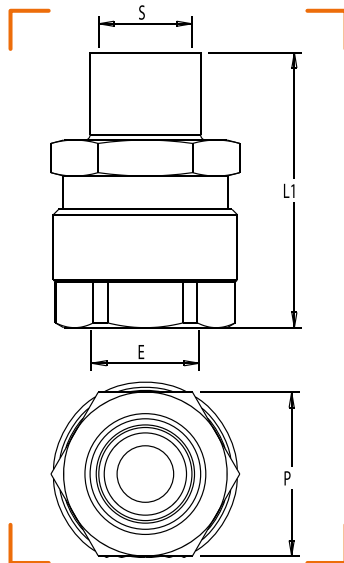

CARACTÉRISTIQUES TECHNIQUES

Normes : NF EN 1555-3+A1 / NF EN 1254-1
Température : -20°C à +60°C

CALIBRE	ENTRÉE PE (E)	SORTIE CU (S)	L1	P	NF	RÉF.
15	PE Ø 20	Cu Ø 18	54	32	x	1120-003
25/20	PE Ø 32	Cu Ø 22	57	41	x	1120-002
25	PE Ø 32	Cu Ø 28	61	41	x	1120-005
32/20	PE Ø 40	Cu Ø 22	79	46	x	1120-006
32	PE Ø 40	Cu Ø 35	79	46	x	1120-007
50	PE Ø 63	Cu Ø 54	106	65	x	1120-012