

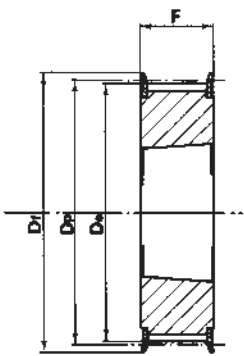

PULEGGE DENTATE HTD® PER BUSSOLA CONICA

HTD® Timing belt pulleys for taper bushes
HTD® Zahnriemenscheiben für Spannbuchsen
Poulies dentées HTD® à moyeu amovible
Poleas dentadas HTD® para casquillos cónicos



Tipo / Type
3F

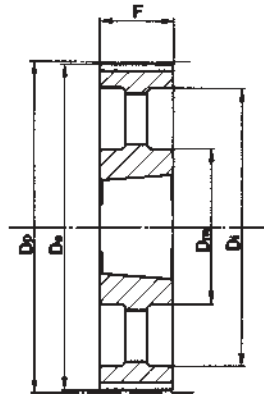

Tipo / Type
3A

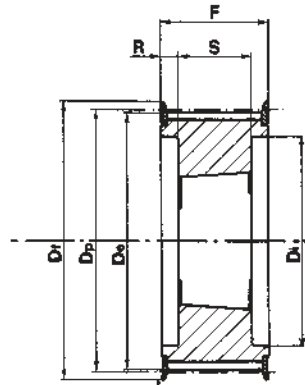

Tipo / Type
4F

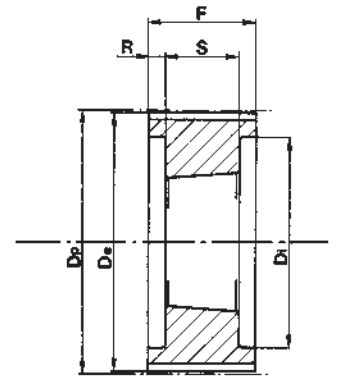

Tipo / Type
4

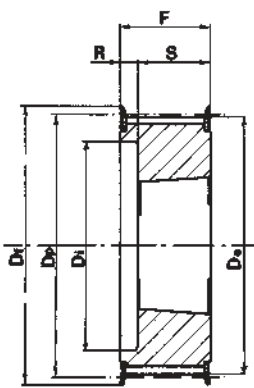

Tipo / Type
5F

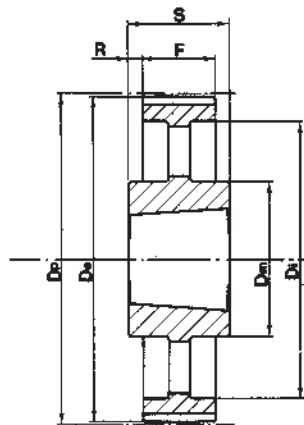

Tipo / Type
7A

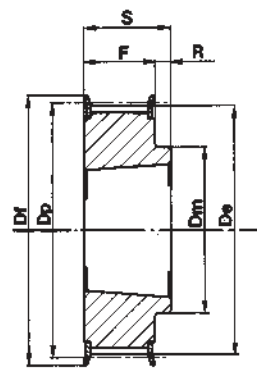

Tipo / Type
8F

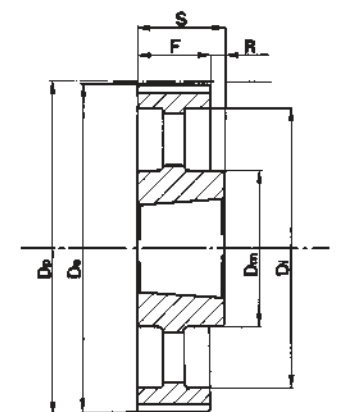

Tipo / Type
8A

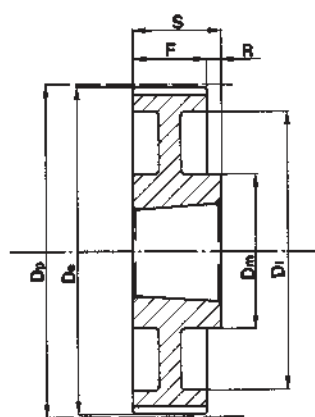

Tipo / Type
8W

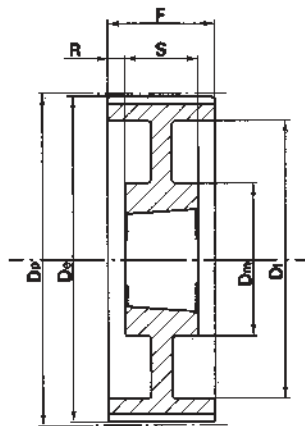

Tipo / Type
9W

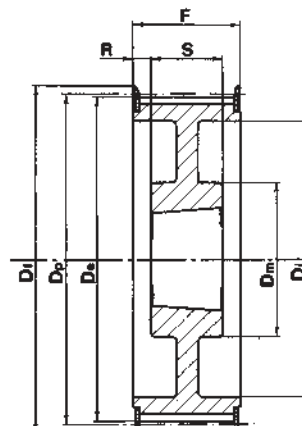

Tipo / Type
9WF

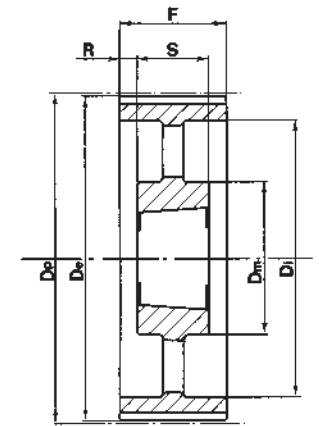

Tipo / Type
9A

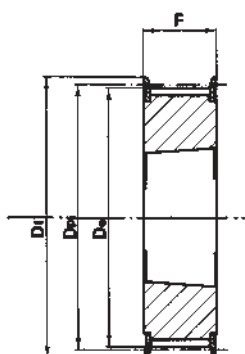

Tipo / Type
3F

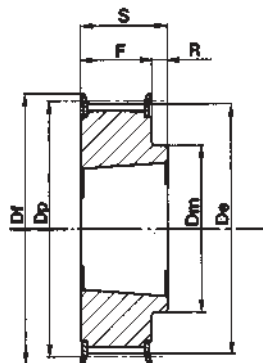

Tipo / Type
8F

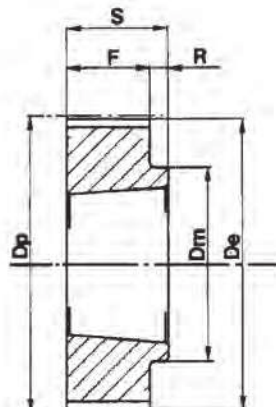

Tipo / Type
8

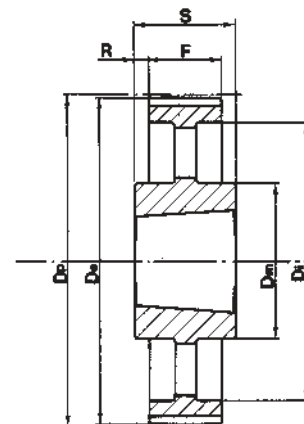

Tipo / Type
7A

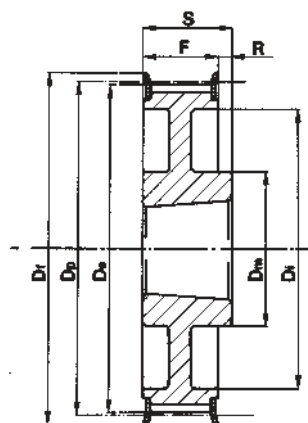

Tipo / Type
8WF

HTD® 5M-15

Caratteristiche Features Merkmale Características	Codice Code symbol Bezeichnung Code symbole Numero de fabrica	Nostro codice Our code Unser Code Notre code Nuestro codigo	Tipo Type Typ Type Tipo	Codice flangia Flange code Bordscheiben Typ Code flasque Código brida	Bussola Bush Buchse Moyeu Casquillo	Foro max. Max. Bore Max. Bohrung Alesage max. Agujero max.	Dp	De	Df	Dm	Di	F	S	R	Peso Weight / Gewicht Poids / Peso Kg	
Acciaio / Steel / Stahl Acier / Acero	con flangia / with flanges mit Flanges / avec flasques / con tapetas	34 5M 15	0515034	3F	FL020	1008	25	54,11	52,97	57,0	-	-	22	22	-	0,19
	36 5M 15	0515036	3F	FL021	1108	25	57,30	56,15	60,0	-	-	22	22	-	0,20	
	38 5M 15	0515038	3F	FL024	1108	25	60,48	59,34	66,5	-	-	22	22	-	0,26	
	40 5M 15	0515040	3F	FL025	1108	25	63,66	62,52	71,0	-	-	22	22	-	0,31	
	44 5M 15	0515044	3F	FL027	1108	25	70,03	68,89	75,0	-	-	22	22	-	0,41	
	48 5M 15	0515048	8F	FL029	1210	32	76,39	75,25	83,0	59	-	22	25	3	0,45	
	56 5M 15	0515056	8F	FL033	1210	32	89,13	87,98	93,0	70	-	22	25	3	0,75	
	64 5M 15	0515064	8F	FL038	1210	32	101,86	100,72	106,0	80	-	22	25	3	1,20	
senza flangia / without flanges ohne Flanschen / sans flasques sin tapetas	72 5M 15	0515072	8	-	1610	42	114,59	113,45	-	92	-	22	25	3	1,35	
	80 5M 15	0515080	8	-	1610	42	127,32	126,18	-	92	-	22	25	3	1,73	
	90 5M 15	0515090	8	-	1610	42	143,24	142,10	-	92	-	22	25	3	2,29	
	112 5M 15	0515112	8	-	2012	50	178,25	177,11	-	110	-	20	32	12	3,71	
	136 5M 15	0515136	7A	-	2012	50	216,45	215,31	-	110	199	20	32	6	3,08	

HTD® 8M-20

Caratteristiche Features Merkmale Características	Codice Code symbol Bezeichnung Code symbole Numero de fabrica	Nostro codice Our code Unser Code Notre code Nuestro codigo	Tipo Type Typ Tipo	Codice flangia Flange code Bordscheiben Typ Code flasque Código brida	Bussola Bush Buchse Moyeu Casquillo	Foro max. Max. Bore Max. Bohrung Alesage max. Agujero max.	Dp	De	Df	Dm	Di	F	S	R	Peso Weight / Gewicht Poids / Peso Kg
Acciaio / Steel / Stahl Acier / Acero con flangia / with flanges mit Flanges / avec flasques / con tapetas	22-8M-20	0820022	5F	FL053	1008	25	56,02	54,65	60,0	-	37	28	22	6	0,25
	24 8M 20	0820024	5F	FL069	1108	25	61,12	59,75	66,0	-	44	28	22	6	0,30
	26 8M 20	0820026	5F	FL061	1108	25	66,21	64,84	70,0	-	45	28	22	6	0,36
	28 8M 20	0820028	5F	FL079	1108	25	71,30	69,93	75,0	-	50	28	22	6	0,44
	30 8M 20	0820030	5F	FL073	1108	25	76,39	75,02	83,0	-	58	28	22	6	0,53
	32 8M 20	0820032	5F	FL076	1610	42	81,49	80,16	87,0	-	63	28	25	3	0,42
	34 8M 20	0820034	5F	FL066	1610	42	86,58	85,22	91,0	-	64	28	25	3	0,55
	36 8M 20	0820036	5F	FL068	1610	42	91,67	90,30	97,0	-	68	28	25	3	0,68
	38 8M 20	0820038	5F	FL070	1610	42	96,77	95,39	102,0	-	72	28	25	3	0,80
	40 8M 20	0820040	5F	FL077	1610	42	101,86	100,49	106,0	-	76	28	25	3	1,00
	44 8M 20	0820044	8F	FL075	2012	50	112,05	110,67	120,0	93	-	28	32	4	1,20
	48 8M 20	0820048	8F	FL078	2012	50	122,23	120,86	128,0	96	-	28	32	4	1,60
	56 8M 20	0820056	8F	FL085	2012	50	142,60	141,23	150,0	110	-	28	32	4	2,40
	64 8M 20	0820064	8F	FL090	2012	50	162,97	161,60	168,0	110	137	28	32	4	2,70
72 8M 20	0820072	8F	FL097	2012	50	183,35	181,97	192,0	110	158	28	32	4	3,30	
Ghisa / Cast iron Grauguss / Fonte Hierro fundido senza flangia / without flanges ohne Flanschen / sans flasques sin tapetas	80 8M 20	0820080	8W	-	2012	50	203,72	202,35	-	110	180	28	32	4	3,50
	90 8M 20	0820090	8A	-	2012	50	229,18	227,81	-	110	204	28	32	4	3,65
	144 8M 20	0820144	8A	-	2517	60	366,69	365,32	-	125	336	28	45	17	4,80

HTD® 8M-30

Caratteristiche Features Merkmale Características	Codice Code symbol Bezeichnung Code symbole Numero de fabrica	Nostro codice Our code Unser Code Notre code Nuestro codigo	Tipo Type Typ Tipo	Codice flangia Flange code Bordscheiben Typ Code flasque Código brida	Bussola Bush Buchse Moyeu Casquillo	Foro max. Max. Bore Max. Bohrung Alesage max. Agujero max.	Dp	De	Df	Dm	Di	F	S	R	Peso Weight / Gewicht Poids / Peso Kg
Acciaio / Steel / Stahl Acier / Acero con flangia / with flanges mit Flanges / avec flasques / con tapetas	22 8M 30	0830022	5F	FL053	1008	25	56,02	54,65	60,0	-	37	38	22	16	0,31
	24 8M 30	0830024	5F	FL069	1108	25	61,12	59,75	66,0	-	44	38	22	16	0,38
	26 8M 30	0830026	5F	FL061	1108	25	66,21	64,84	70,0	-	44	38	22	16	0,45
	28 8M 30	0830028	5F	FL079	1210	32	71,30	69,93	75,0	-	50	38	25	13	0,50
	30 8M 30	0830030	3F	FL073	1615	42	76,39	75,02	83,0	-	-	38	38	-	0,55
	32 8M 30	0830032	3F	FL076	1615	42	81,49	80,16	87,0	-	-	38	38	-	0,59
	34 8M 30	0830034	3F	FL066	1615	42	86,58	85,22	91,0	-	-	38	38	-	0,77
	36 8M 30	0830036	3F	FL068	1615	42	91,67	90,30	97,0	-	-	38	38	-	0,96
	38 8M 30	0830038	3F	FL070	1615	42	96,77	95,39	102,0	-	-	38	38	-	1,15
	40 8M 30	0830040	3F	FL077	1615	42	101,86	100,49	106,0	-	-	38	38	-	1,34
	44 8M 30	0830044	4F	FL075	2012	50	112,05	110,67	120,0	-	86	38	32	3	1,33
	48 8M 30	0830048	4F	FL078	2012	50	122,23	120,86	128,0	-	90	38	32	3	1,78
	56 8M 30	0830056	4F	FL085	2012	50	142,60	141,23	150,0	-	110	38	32	3	3,76
	64 8M 30	0830064	8F	FL090	2517	60	162,97	161,60	168,0	125	-	38	45	7	4,20
72 8M 30	0830072	8F	FL097	2517	60	183,35	181,97	192,0	125	158	38	45	7	4,30	
Ghisa / Cast iron Grauguss / Fonte Hierro fundido senza flangia / without flanges ohne Flanschen / sans flasques sin tapetas	80 8M 30	0830080	8W	-	2517	60	203,72	202,35	-	125	180	38	45	7	4,60
	90 8M 30	0830090	8A	-	2517	60	229,18	227,81	-	125	204	38	45	7	5,00
	112 8M 30	0830112	8A	-	2517	60	285,21	283,83	-	125	254	38	45	7	6,20
	144 8M 30	0830144	8A	-	2517	60	366,69	365,32	-	125	336	38	45	7	9,00

Pulegge dentate HTD® per bussola conica / HTD® Timing belt pulleys for taper bushes
HTD® Zahnriemenscheiben für Spannbüchsen / Poulies dentées HTD® à moyeu amovible
Poleas dentadas HTD® para casquillos cónicos



HTD® 8M-50

Caratteristiche Features Merkmale Características	Codice Code symbol Bezeichnung Code symbole Numero de fabrica	Nostro codice Our code Unser Code Notre code Nuestro codigo	Tipo Type Typ Type Tipo	Codice flangia Flange code Bordscheiben Typ Code flasque Código brida	Bussola Bush Buchse Moyeu Casquillo	Foro max. Max. Bore Max. Bohrung Alesage max. Agujero max.	Dp	De	Df	Dm	Di	F	S	R	Peso Weight / Gewicht Poids / Peso Kg
Acciaio / Steel / Stahl Acier / Acero con flangia / with flanges mit Flanges / avec flasques / con tapetas	28 8M 50	0850028	4F	FL079	1210	32	71,30	69,93	75,0	-	50	60	25	17,5	0,60
	30 8M 50	0850030	5F	FL073	1615	42	76,39	75,02	83,0	-	58	60	38	22,0	0,65
	32 8M 50	0850032	5F	FL076	1615	42	81,49	80,16	87,0	-	62	60	38	22,0	0,82
	34 8M 50	0850034	5F	FL066	1615	42	86,58	85,22	91,0	-	65	60	38	22,0	1,06
	36 8M 50	0850036	5F	FL068	1615	42	91,67	90,30	97,0	-	68	60	38	22,0	1,30
	38 8M 50	0850038	5F	FL070	1615	42	96,77	95,39	102,0	-	72	60	38	22,0	1,60
	40 8M 50	0850040	4F	FL077	2012	50	101,86	100,49	106,0	-	82	60	32	14,0	1,71
	44 8M 50	0850044	4F	FL075	2012	50	112,05	110,67	120,0	-	91	60	32	14,0	1,78
	48 8M 50	0850048	4F	FL078	2012	50	122,23	120,86	128,0	-	95	60	32	14,0	2,30
	56 8M 50	0850056	4F	FL085	2517	60	142,60	141,23	150,0	-	116	60	45	7,5	3,40
	64 8M 50	0850064	4F	FL090	2517	60	162,97	161,60	168,0	-	137	60	45	7,5	5,00
72 8M 50	0850072	9WF	FL097	2517	60	183,35	181,97	192,0	125	158	60	45	7,5	6,70	
Ghisa / Cast iron Grauguss / Fonte Hierro fundido senza flangia / without flanges ohne Flanschen / sans flasques sin tapetas	80 8M 50	0850080	4	-	3020	75	203,72	202,35	-	-	180	60	51	4,5	8,80
	90 8M 50	0850090	9W	-	3020	75	229,18	227,81	-	170	204	60	51	4,5	10,00
	112 8M 50	0850112	9W	-	3020	75	285,21	283,83	-	170	260	60	51	4,5	12,00
	144 8M 50	0850144	9A	-	3020	75	366,69	365,32	-	170	341	60	51	4,5	15,20
	168 8M 50	0850168	7A	-	3525	90	427,81	426,44	-	198	395	60	65	2,5	17,50
	192 8M 50	0850192	7A	-	3525	90	488,92	487,55	-	198	455	60	65	2,5	24,00

HTD® 8M-85

Caratteristiche Features Merkmale Características	Codice Code symbol Bezeichnung Code symbole Numero de fabrica	Nostro codice Our code Unser Code Notre code Nuestro codigo	Tipo Type Typ Type Tipo	Codice flangia Flange code Bordscheiben Typ Code flasque Código brida	Bussola Bush Buchse Moyeu Casquillo	Foro max. Max. Bore Max. Bohrung Alesage max. Agujero max.	Dp	De	Df	Dm	Di	F	S	R	Peso Weight / Gewicht Poids / Peso Kg
Acciaio / Steel / Stahl Acier / Acero con flangia / with flanges mit Flanges / avec flasques / con tapetas	34 8M 85	0885034	4F	FL066	1615	42	86,58	85,22	91,0	-	65	95	38	28,5	1,43
	36 8M 85	0885036	4F	FL068	1615	42	91,67	90,30	97,0	-	68	95	38	28,5	1,87
	38 8M 85	0885038	4F	FL070	1615	42	96,77	95,39	102,0	-	72	95	38	28,5	2,20
	40 8M 85	0885040	4F	FL077	2012	50	101,86	100,49	106,0	-	82	95	32	31,5	1,80
	44 8M 85	0885044	4F	FL075	2012	50	112,05	110,67	120,0	-	91	95	32	31,5	2,30
	48 8M 85	0885048	4F	FL078	2517	60	122,23	120,86	128,0	-	100	95	45	25,0	2,66
	56 8M 85	0885056	4F	FL085	2517	60	142,60	141,23	150,0	-	117	95	45	25,0	4,45
	64 8M 85	0885064	4F	FL090	2517	60	162,97	161,60	168,0	-	137	95	45	25,0	6,20
72 8M 85	0885072	4F	FL097	3020	75	183,35	181,97	192,0	-	158	95	51	22,0	8,00	
Ghisa / Cast iron Grauguss / Fonte Hierro fundido senza flangia / without flanges ohne Flanschen / sans flasques sin tapetas	80 8M 85	0885080	4	-	3020	75	203,72	202,35	-	-	180	95	51	22,0	10,00
	90 8M 85	0885090	9W	-	3020	75	229,18	227,81	-	170	204	95	51	22,0	10,80
	112 8M 85	0885112	9W	-	3020	75	285,21	283,83	-	170	260	95	51	22,0	15,00
	144 8M 85	0885144	9A	-	3525	90	366,69	365,32	-	198	336	95	65	15,0	20,00
	168 8M 85	0885168	9A	-	3525	90	427,81	426,44	-	198	395	95	65	15,0	22,00
	192 8M 85	0885192	9A	-	3525	90	488,92	487,55	-	198	455	95	65	15,0	26,00

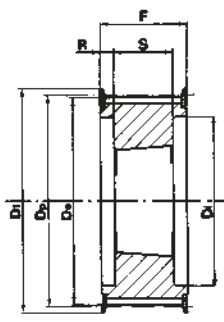

Tipo / Type
4F

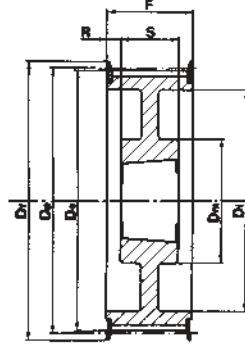

Tipo / Type
9WF

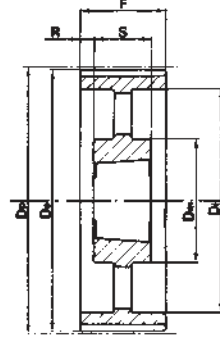

Tipo / Type
9A

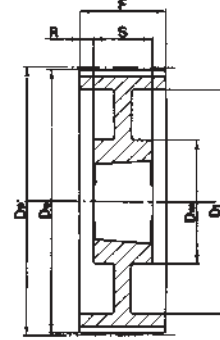

Tipo / Type
9W

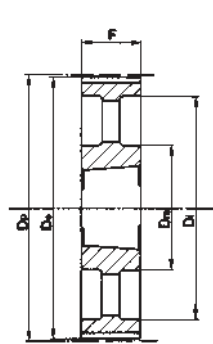

Tipo / Type
3A

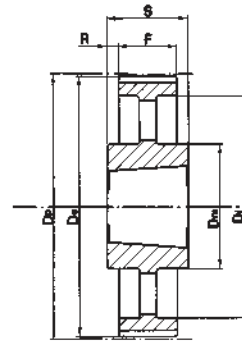

Tipo / Type
7A

HTD® 14M-40

Caratteristiche Features Merkmale Características Características	Codice Code symbol Bezeichnung Code symbole Numero de fabrica	Nostro codice Our code Unser Code Notre code Nuestro codigo	Tipo Type Typ Type Tipo	Codice flangia Flange code Bordscheiben Typ Code flasque Código brida	Bussola Bush Buchse Moyeu Casquillo	Foro max. Max. Bore Max. Bohrung Alesage max. Agujero max.	Dp	De	Df	Dm	Di	F	S	R	Peso Weight / Gewicht Poids / Peso Kg
Acciaio / Steel / Stahl Acier / Acero	28 14M 40	1440028	4F	FL153	2012	50	124,78	122,12	128,0	-	94	54	32	11,0	2,07
	29 14M 40	1440029	4F	FL154	2012	50	129,23	126,57	138,0	-	98	54	32	11,0	2,38
	30 14M 40	1440030	4F	FL154	2012	50	133,69	130,99	138,0	-	98	54	32	11,0	2,65
	32 14M 40	1440032	4F	FL160	2012	50	142,60	139,88	154,0	-	108	54	32	11,0	3,40
	34 14M 40	1440034	4F	FL166	2517	60	151,52	148,79	160,0	-	110	54	45	4,5	3,87
	36 14M 40	1440036	4F	FL168	2517	60	160,43	157,68	168,0	-	120	54	45	4,5	4,80
	38 14M 40	1440038	4F	FL172	2517	60	169,34	166,60	183,0	-	130	54	45	4,5	5,40
	40 14M 40	1440040	4F	FL162	2517	60	178,25	175,49	188,0	-	138	54	45	4,5	6,00
	44 14M 40	1440044	4F	FL175	3020	75	196,08	193,28	211,0	-	155	54	51	1,5	7,80
	48 14M 40	1440048	4F	FL180	3020	75	213,90	211,11	226,0	-	170	54	51	1,5	9,40
	56 14M 40	1440056	9WF	FL182	3020	75	249,55	246,76	256,0	170	208	54	51	1,5	10,80
	64 14M 40	1440064	9WF	FL184	3020	75	285,21	282,41	296,0	170	240	54	51	1,5	13,40
Ghisa / Cast iron Grauguss / Fonte Hierro fundido	72 14M 40	1440072	9W	-	3020	75	320,86	318,06	-	170	280	54	51	1,5	15,20
	80 14M 40	1440080	9A	-	3020	75	356,51	353,71	-	170	315	54	51	1,5	16,00
	90 14M 40	1440090	9A	-	3020	75	401,07	398,28	-	170	360	54	51	1,5	17,80
	112 14M 40	1440112	9A	-	3020	75	499,11	496,32	-	170	457	54	51	1,5	25,60
	144 14M 40	1440144	9A	-	3020	75	641,71	638,92	-	170	600	54	51	1,5	32,00
	168 14M 40	1440168	9A	-	3020	75	748,66	745,87	-	170	706	54	51	1,5	44,00
	192 14M 40	1440192	9A	-	3535	90	855,62	852,82	-	190	813	54	51	1,5	49,00
	216 14M 40	1440216	9A	-	3535	90	962,57	959,76	-	190	920	54	51	1,5	55,00

Pulegge dentate HTD® per bussola conica / HTD® Timing belt pulleys for taper bushes
HTD® Zahnriemenscheiben für Spannbüchsen / Poulies dentées HTD® à moyeu amovible
Poleas dentadas HTD® para casquillos cónicos



HTD® 14M-55

Caratteristiche Features Merkmale Características	Codice Code symbol Bezeichnung Code symbole Numero de fabrica	Nostro codice Our code Unser Code Notre code Nuestro codigo	Tipo Type Typ Type Tipo	Codice flangia Flange code Bordscheiben Typ Code flasque Código brida	Bussola Bush Buchse Moyeu Casquillo	Foro max. Max. Bore Max. Bohrung Alesage max. Agujero max.	Dp	De	Df	Dm	Di	F	S	R	Peso Weight / Gewicht Poids / Peso Kg
Acciaio / Steel / Stahl Acier / Acero	28 14M 55	1455028	4F	FL153	2012	50	124,78	122,12	128,0	-	94	70	32	19,0	2,20
	29 14M 55	1455029	4F	FL154	2012	50	129,23	126,57	138,0	-	100	70	32	19,0	2,74
	30 14M 55	1455030	4F	FL154	2517	60	133,69	130,99	138,0	-	100	70	45	12,5	2,70
	32 14M 55	1455032	4F	FL160	2517	60	142,60	139,88	154,0	-	108	70	45	12,5	3,66
	34 14M 55	1455034	4F	FL166	2517	60	151,52	148,79	160,0	-	110	70	45	12,5	4,55
	36 14M 55	1455036	4F	FL168	2517	60	160,43	157,68	168,0	-	120	70	45	12,5	5,20
	38 14M 55	1455038	4F	FL172	2517	60	169,34	166,60	183,0	-	130	70	45	12,5	6,20
	40 14M 55	1455040	4F	FL162	2517	60	178,25	175,49	188,0	-	138	70	45	12,5	7,00
	44 14M 55	1455044	4F	FL175	3020	75	196,08	193,28	211,0	-	155	70	51	9,5	8,60
	48 14M 55	1455048	4F	FL180	3020	75	213,90	211,11	226,0	-	170	70	51	9,5	10,40
	56 14M 55	1455056	9WF	FL182	3020	75	249,55	246,76	256,0	170	208	70	51	9,5	12,40
Ghisa / Cast iron / Grauguss Fonte / Hierro fundido	64 14M 55	1455064	9WF	FL184	3020	75	285,21	282,41	296,0	170	240	70	51	9,5	14,50
	72 14M 55	1455072	9W	-	3020	75	320,86	318,06	-	170	280	70	51	9,5	16,20
	80 14M 55	1455080	9A	-	3020	75	356,51	353,71	-	170	315	70	51	9,5	17,50
	90 14M 55	1455090	9A	-	3020	75	401,07	398,28	-	170	360	70	51	9,5	20,10
	112 14M 55	1455112	9A	-	3020	75	499,11	496,32	-	170	457	70	51	9,5	28,40
	144 14M 55	1455144	9A	-	3020	75	641,71	638,92	-	170	600	70	51	9,5	36,20
	168 14M 55	1455168	9A	-	3020	75	748,66	745,87	-	170	706	70	51	9,5	49,00
	192 14M 55	1455192	9A	-	3535	90	855,62	852,82	-	170	813	70	51	9,5	53,00
	216 14M 55	1455216	7A	-	3535	90	962,57	959,76	-	190	920	70	89	9,5	65,80

HTD® 14M 85

Caratteristiche Features Merkmale Características	Codice Code symbol Bezeichnung Code symbole Numero de fabrica	Nostro codice Our code Unser Code Notre code Nuestro codigo	Tipo Type Typ Type Tipo	Codice flangia Flange code Bordscheiben Typ Code flasque Código brida	Bussola Bush Buchse Moyeu Casquillo	Foro max. Max. Bore Max. Bohrung Alesage max. Agujero max.	Dp	De	Df	Dm	Di	F	S	R	Peso Weight / Gewicht Poids / Peso Kg
Acciaio / Steel / Stahl Acier / Acero	28 14M 85	1485028	4F	FL153	2517	60	124,78	122,12	128,0	-	98	102	45	28,5	2,70
	29 14M 85	1485029	4F	FL154	2517	60	129,23	126,57	138,0	-	100	102	45	28,5	3,40
	30 14M 85	1485030	4F	FL154	2517	60	133,69	130,99	138,0	-	100	102	45	28,5	3,75
	32 14M 85	1485032	4F	FL160	2517	60	142,60	139,88	154,0	-	108	102	45	28,5	4,80
	34 14M 85	1485034	4F	FL166	2517	60	151,52	148,79	160,0	-	110	102	45	28,5	6,00
	36 14M 85	1485036	4F	FL168	3020	75	160,43	157,68	168,0	-	120	102	51	25,5	5,80
	38 14M 85	1485038	4F	FL172	3020	75	169,34	166,60	183,0	-	130	102	51	25,5	6,80
	40 14M 85	1485040	4F	FL162	3020	75	178,25	175,49	188,0	-	138	102	51	25,5	8,00
	44 14M 85	1485044	4F	FL175	3020	75	196,08	193,28	211,0	-	153	102	51	25,5	11,80
	48 14M 85	1485048	4F	FL180	3020	75	213,90	211,11	226,0	-	170	102	51	25,5	15,10
	56 14M 85	1485056	4F	FL182	3525	90	249,55	246,76	256,0	-	210	102	65	18,5	19,00
Ghisa / Cast iron / Grauguss Fonte / Hierro fundido	64 14M 85	1485064	9WF	FL184	3525	90	285,21	282,41	296,0	190	240	102	65	18,5	23,00
	72 14M 85	1485072	9W	-	3525	90	320,86	318,06	-	190	280	102	65	18,5	25,00
	80 14M 85	1485080	9A	-	3525	90	356,51	353,71	-	190	315	102	65	18,5	26,00
	90 14M 85	1485090	9A	-	3525	90	401,07	398,28	-	190	360	102	65	18,5	27,80
	112 14M 85	1485112	9A	-	3525	90	499,11	496,32	-	190	457	102	65	18,5	36,50
	144 14M 85	1485144	9A	-	3525	90	641,71	638,92	-	190	600	102	65	18,5	48,00
	168 14M 85	1485168	9A	-	3525	90	748,66	745,87	-	190	706	102	65	18,5	60,00
	192 14M 85	1485192	3A	-	4040	100	855,62	852,82	-	190	813	102	102	-	86,00
	216 14M 85	1485216	3A	-	4040	100	962,57	959,76	-	190	920	102	102	-	91,50

HTD® 14M-115

Caratteristiche Features Merkmale Características	Codice Code symbol Bezeichnung Code symbole Numero de fabrica	Nostro codice Our code Unser Code Notre code Nuestro codigo	Tipo Type Typ Type Tipo	Codice flangia Flange code Bordscheiben Typ Code flasque Código brida	Bussola Bush Buchse Moyeu Casquillo	Foro max. Max. Bore Max. Bohrung Alesage max. Agujero max.	Dp	De	Df	Dm	Di	F	S	R	Peso Weight / Gewicht Poids / Peso Kg
Acciaio / Steel / Stahl Acier / Acero	28-14M-115	1411028	4F	FL153	2517	60	124,78	122,12	128,0	-	98	133	45	44,0	3,77
	29-14M-115	1411029	4F	FL154	2517	60	129,23	126,57	138,0	-	100	133	45	44,0	4,00
	30-14M-115	1411030	4F	FL154	2517	60	133,69	130,99	138,0	-	100	133	45	44,0	5,00
	32-14M-115	1411032	4F	FL160	2517	60	142,60	139,88	154,0	-	108	133	45	44,0	6,80
	34-14M-115	1411034	4F	FL166	2517	60	151,52	148,79	160,0	-	110	133	45	44,0	6,80
	36-14M-115	1411036	4F	FL168	3020	75	160,43	157,68	168,0	-	125	133	51	41,0	7,00
	38-14M-115	1411038	4F	FL172	3020	75	169,34	166,60	183,0	-	130	133	51	41,0	8,40
	40-14M-115	1411040	4F	FL162	3020	75	178,25	175,49	188,0	-	138	133	51	41,0	9,20
	44-14M-115	1411044	4F	FL175	3030	75	196,08	193,28	211,0	-	155	133	76	28,5	14,00
	48-14M-115	1411048	4F	FL180	3030	75	213,90	211,11	226,0	-	170	133	76	28,5	17,10
	56-14M-115	1411056	4F	FL182	3535	90	249,55	246,76	256,0	-	208	133	89	22,0	24,80
64-14M-115	1411064	9WF	FL184	3535	90	285,21	282,41	296,0	190	240	133	89	22,0	27,00	
Ghisa / Cast iron / Grauguss Fonte / Hierro fundido	72-14M-115	1411072	9W	-	3535	90	320,86	318,06	-	190	280	133	89	22,0	29,00
	80-14M-115	1411080	9A	-	3535	90	356,51	353,71	-	190	315	133	89	22,0	32,00
	90-14M-115	1411090	9A	-	3535	90	401,07	398,28	-	190	360	133	89	22,0	36,50
	112-14M-115	1411112	9A	-	3535	90	499,11	496,32	-	190	457	133	89	22,0	46,00
	144-14M-115	1411144	9A	-	4040	100	641,71	638,92	-	230	600	133	102	15,5	68,00
	168-14M-115	1411168	9A	-	4040	100	748,66	745,87	-	230	706	133	102	15,5	82,60
	192-14M-115	1411192	9A	-	4040	100	855,62	852,82	-	230	813	133	102	15,5	96,00
	216-14M-115	1411216	9A	-	4040	100	962,57	959,76	-	230	920	133	102	15,5	107,00

HTD® 14M-170

Caratteristiche Features Merkmale Características	Codice Code symbol Bezeichnung Code symbole Numero de fabrica	Nostro codice Our code Unser Code Notre code Nuestro codigo	Tipo Type Typ Type Tipo	Codice flangia Flange code Bordscheiben Typ Code flasque Código brida	Bussola Bush Buchse Moyeu Casquillo	Foro max. Max. Bore Max. Bohrung Alesage max. Agujero max.	Dp	De	Df	Dm	Di	F	S	R	Peso Weight / Gewicht Poids / Peso Kg
Acciaio / Steel / Stahl Acier / Acero	38-14M-170	1417038	4F	FL172	3030	75	169,34	166,60	183,0	-	130	187	76	55,5	11,70
	40-14M-170	1417040	4F	FL162	3030	75	178,25	175,49	188,0	-	138	187	76	55,5	13,00
	44-14M-170	1417044	4F	FL175	3535	90	196,08	193,28	211,0	-	153	187	89	49,0	15,00
	48-14M-170	1417048	4F	FL180	3535	90	213,90	211,11	226,0	-	170	187	89	49,0	19,00
	56-14M-170	1417056	4F	FL182	3535	90	249,55	246,76	256,0	-	208	187	89	49,0	28,50
64-14M-170	1417064	4F	FL184	4040	100	285,21	282,41	296,0	-	240	187	102	42,5	41,00	
Ghisa / Cast iron / Grauguss Fonte / Hierro fundido	72-14M-170	1417072	9W	-	4040	100	320,86	318,06	-	230	280	187	102	42,5	46,90
	80-14M-170	1417080	9W	-	4040	100	356,51	353,71	-	230	315	187	102	42,5	48,00
	90-14M-170	1417090	9A	-	4040	100	401,07	398,28	-	230	360	187	102	42,5	52,50
	112-14M-170	1417112	9A	-	5050	125	499,11	496,32	-	265	457	187	127	30,0	74,50
	144-14M-170	1417144	9A	-	5050	125	641,71	638,92	-	265	600	187	127	30,0	91,00
	168-14M-170	1417168	9A	-	5050	125	748,66	745,87	-	265	706	187	127	30,0	116,00
	192-14M-170	1417192	9A	-	5050	125	855,62	852,82	-	265	813	187	127	30,0	134,00
	216-14M-170	1417216	9A	-	5050	125	962,57	959,76	-	265	920	187	127	30,0	146,50