

Electric Actuators



Rod Type

Guide Rod Type

Step Motor (Servo/24 VDC)

Servo Motor (24 VDC) Type



Rod Type Series LEY

Size: 16, 25, 32, 40

Long stroke:

Max. 500 mm (LEY32, 40)

Mounting variations

- Direct mounting: 3 directions, Bracket mounting: 3 types
- Either positioning or pushing control can be selected. Possible to hold the actuator with the rod pushing to a workpiece, etc.

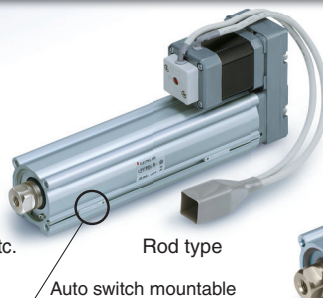

Rod type

Auto switch mountable

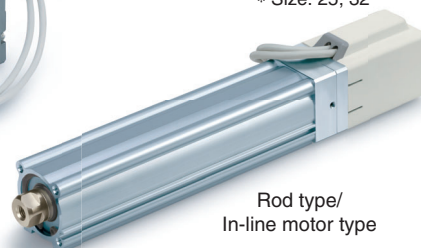

Rod type/
In-line motor type

Dust/Drip proof (IP65 equivalent): -X5

* Size: 25, 32

Guide Rod Type Series LEYG

Size: 16, 25, 32, 40

Lateral end load: **5 times more***

* Compared with rod type, size 25 and 100 stroke

Compatible with sliding bearing and ball bushing bearing.
Compatible with moment load and stopper (sliding bearing).

- Either positioning or pushing control can be selected. Possible to hold the actuator with the rod pushing to a workpiece, etc.

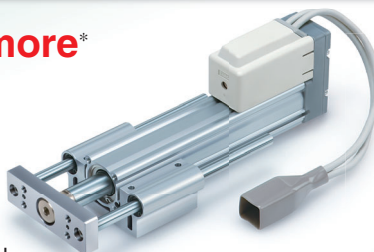

Guide rod type

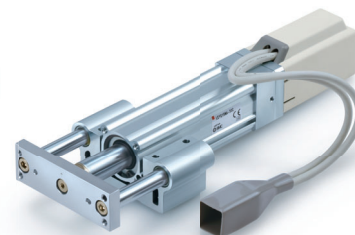

Guide rod type/
In-line motor type

AC Servo Motor Type

* Not applicable to UL.



* Refer to "How to Order"

Rod Type Series LEY Size: 25, 32, 63 Note)

- High output motor (100/200/400 W)
- Improved high speed transfer ability
- High acceleration/deceleration compatible (5,000 mm/s²)
- Pulse input/CC-Link/SSCNET III types
- With internal absolute encoder (For LECSB/C/S)

Dust/Drip proof (IP65 equivalent): -X5

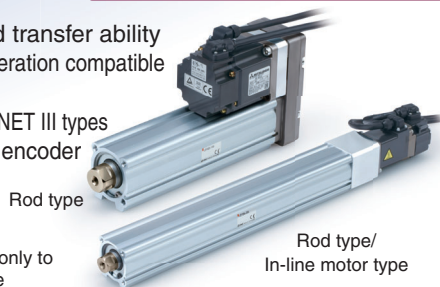

Rod type

Rod type/
In-line motor type

Note) LEY63 is applicable only to the in-line motor type

Guide Rod Type Series LEYG Size: 25, 32

Guide rod type

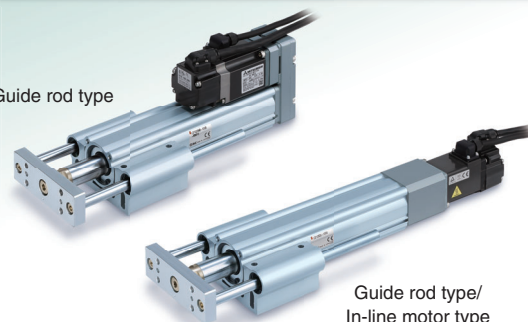

Guide rod type/
In-line motor type

Step Motor (Servo/24 VDC)

Controller/
Driver



Servo Motor (24 VDC)

▶ Fieldbus compatible

- ▶ Step data input type Series LECP6/LECA6
- ▶ Step data input type Series JXC73/83
- ▶ Programless type Series LECP1
- ▶ Pulse input type Series LECPA



AC Servo Motor

Driver * Not applicable to UL.



- ▶ For absolute encoder
- Pulse input type Series LECSB
- CC-Link direct input type Series LECS
- SSCNET III type Series LECS
- SSCNET III/H type Series LECS-T
- MECHATROLINK type Series LECY□



- ▶ For incremental encoder
- Pulse input type/ Positioning type Series LECSA



Series LEY



CAT.EUS100-83Dd-UK

Series LEY

Step Motor (Servo/24 VDC) Servo Motor (24 VDC) Type

Rod Type Series LEY / Size: 16, 25, 32, 40

Control of intermediate positioning and pushing is possible.
High precision with ball screws (Positioning repeatability: ± 0.02 mm)

Motor mounting position selectable

Top mounting type is the standard product.

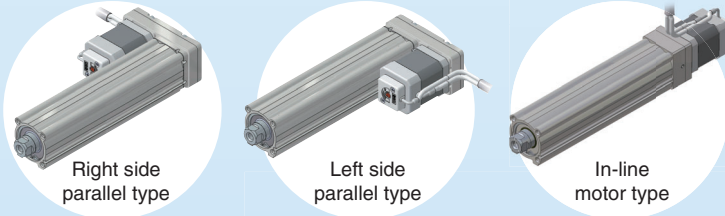

Right side parallel type

Left side parallel type

In-line motor type

Non-magnetizing lock mechanism (Option)

Prevents a workpiece from dropping. (Holding)

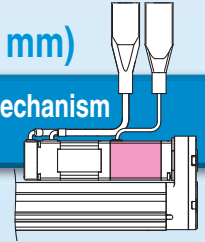

Motor cover available (Option)



Offering 2 types of actuator cables

- Standard cable
- Robotic cable (Flexible cable)

Manual override screw

For manual piston rod operation
Adjustment operation possible when power OFF

Scraper

Prevents foreign matter from entering.

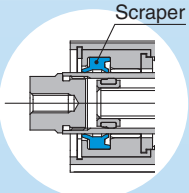

Scraper

Pages 25, 26

Rod end brackets

Single knuckle joint

Double knuckle joint

Simple joint

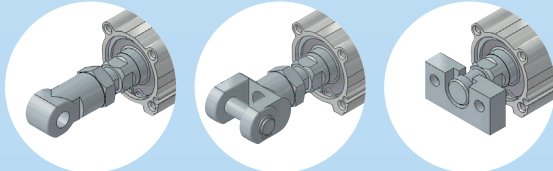

Groove for auto switch

For checking the limit and intermediate signal
Applicable to the D-M9□ and D-M9□W (2-colour indication)

* The auto switches should be ordered separately. Refer to pages 27 and 28 for details.

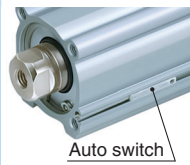

Auto switch

2-colour indication solid state auto switch

Appropriate setting of the mounting position can be performed without mistakes.

A green light lights up at the optimum operating range.

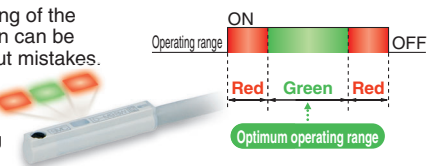

2 types of motors selectable

- Step motor (Servo/24 VDC)
Ideal for transfer of high load at a low speed and pushing operation
- Servo motor (24 VDC)
Stable at high speed and silent operation

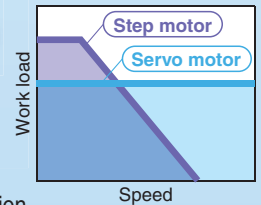

In-line motor type Height dimension shortened by up to 49 %

For LEY16D

* When "Motor option/With motor cover" is selected.

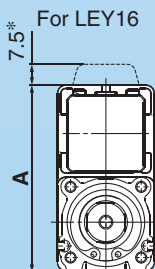
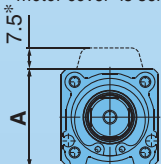

A Dimension		[mm]
Size	In-line motor	Motor top mounting
16	35.5	67.5
25	46.5	92
32, 40	61	118



AC Servo Motor Type

Rod Type Series LEY / Size: 25, 32, 63

- High output motor (100/200/400 W)
- Improved high speed transfer ability
- High acceleration/deceleration compatible (5000 mm/s²)
- Pulse input/CC-Link direct input/SSCNET III types
- With internal absolute encoder
 - * Incremental encoder can also be selected.
- Positioning repeatability ± 0.01 mm (High precision type)

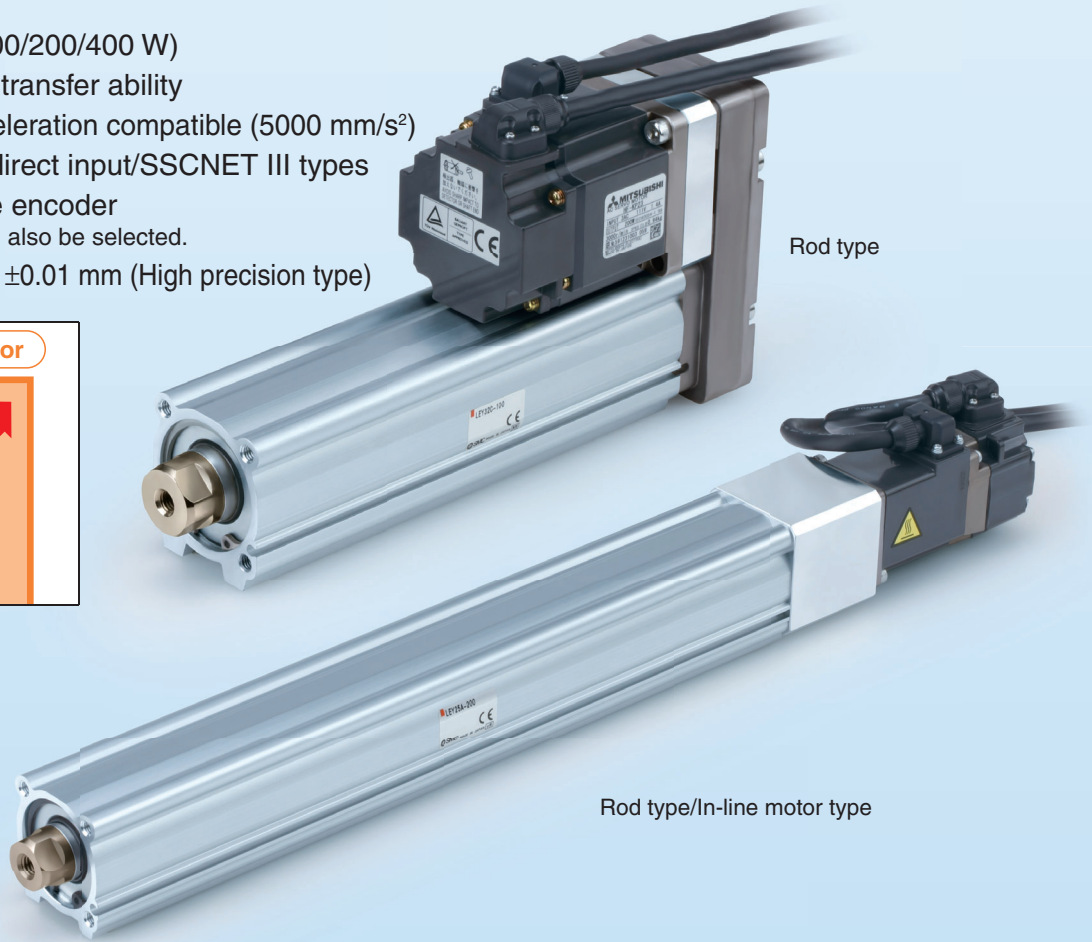
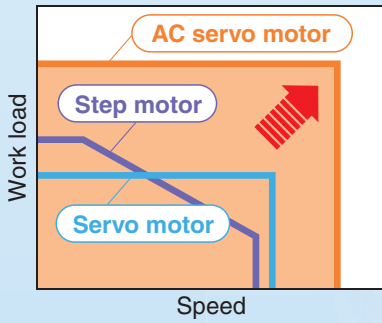

Large bore size 63

Motor mounting position can be selected from 4 directions!

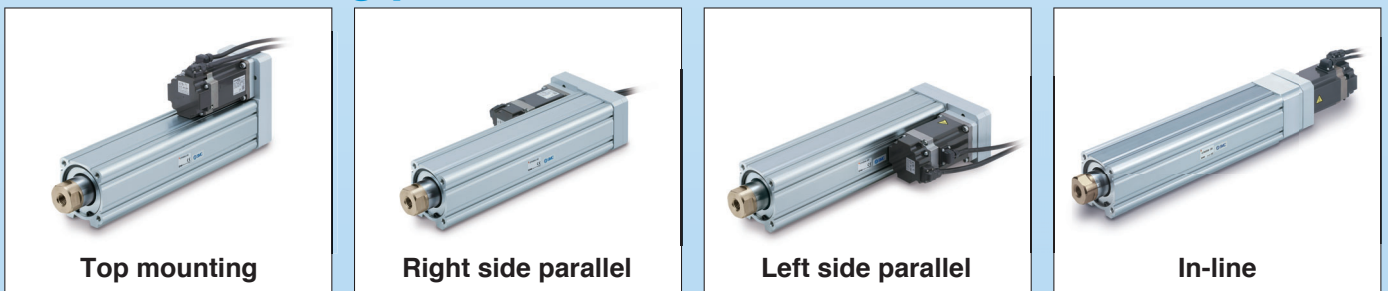

• Max. work load (kg)

	Top/Parallel	In-line
Horizontal	200	80
Vertical	115	72

• Max. force (N)

Top/Parallel	3343
In-line	1910

• High output motor: 400 w

• Max. speed: 1000 mm/s

* 500 mm stroke

• Dust/Drip proof (IP65 equivalent)

Series LEY

Step Motor (Servo/24 VDC)

Servo Motor (24 VDC) Type

Guide Rod Type

Series LEYG /Size: 16, 25, 32, 40

Compact integrated guide rods Lateral load resistance and high non-rotating accuracy

Compatible with sliding bearing and ball bushing bearing

- **Sliding bearing**
Suitable for lateral load applications such as a stopper where shock is applied
- **Ball bushing bearing**
Smooth operation suitable for pusher and lifter

Improved rigidity

Lateral end load: **5 times more***

* Compared with rod type, size 25 and 100 stroke

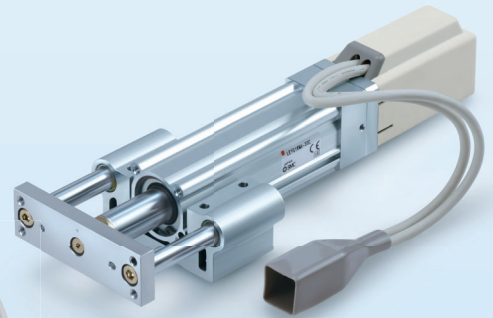
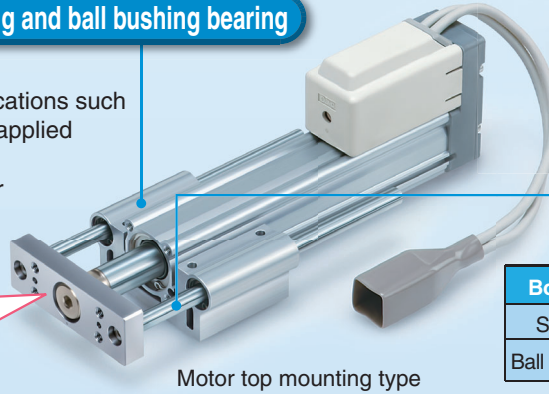

Non-rotating accuracy improved by using two guide rods

Bore size [mm]	16	25	32	40
Sliding bearing	±0.06°		±0.05°	
Ball bushing bearing	±0.05°		±0.04°	

When the cylinder is retracted (initial value), the non-rotating accuracy without a load or deflection of the guide rods will be below the values shown in the table.

AC Servo Motor Type

Guide Rod Type

Series LEYG /Size: 25, 32

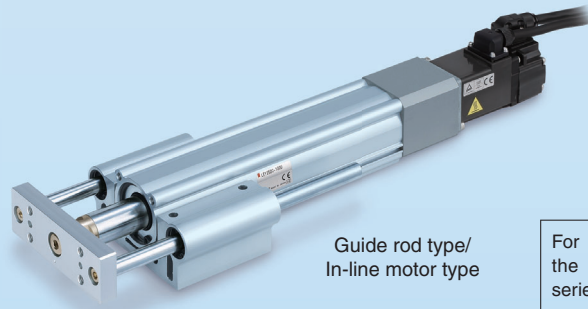
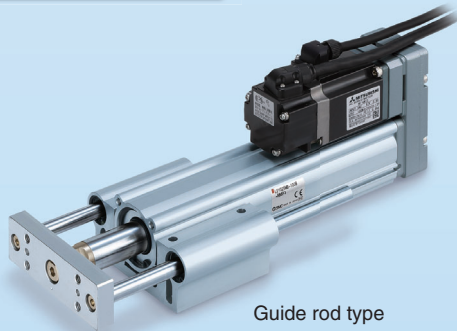

For use of auto switches for the guide rod type LEYG series, refer to page 169.

Mounting Variations

Direct Mounting

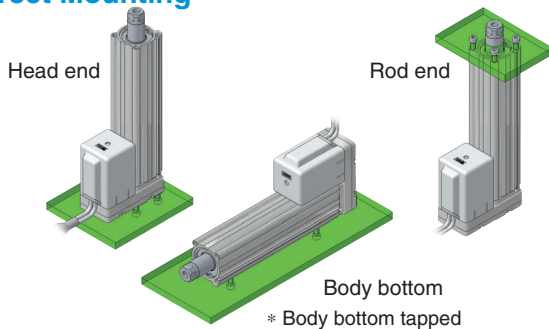

Bracket Mounting

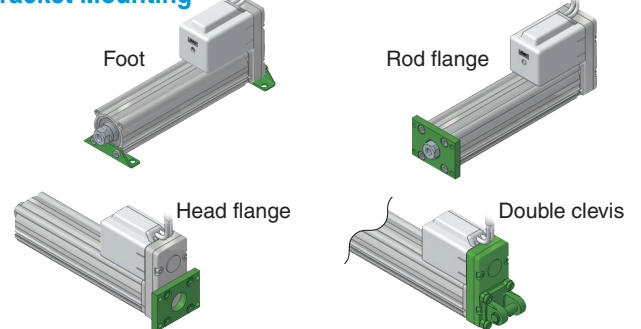

Application Examples

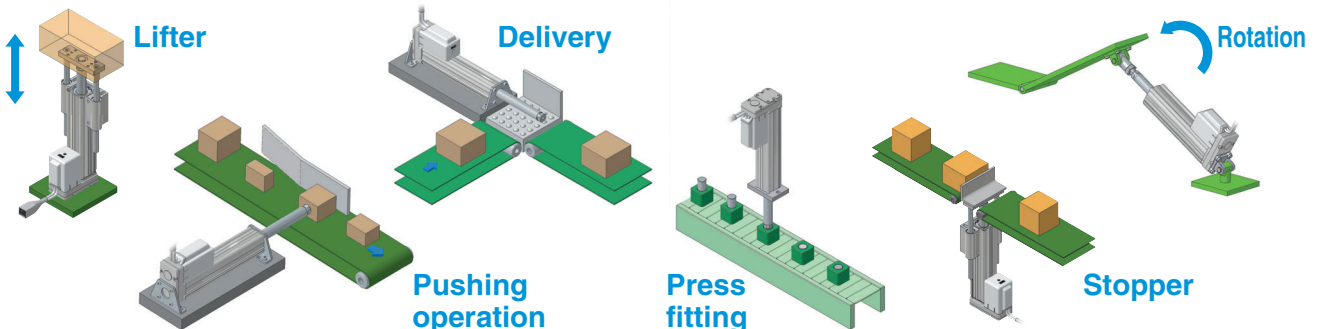

Dust/Drip proof (IP65 equivalent)

Note) IP65 enclosure: The protection structure against solid foreign objects is dust-tight type and the protection structure against water is water-jet-proof type. Dust-tight means that no dust can enter the inside of the equipment. Water-jet-proof means that the product is not adversely affected by direct water jets from any direction. That is, even when direct water jets are applied to the product for 3 minutes by means of the pre-determined method, there is no water entry that hinders correct operation inside the equipment. Be sure to take appropriate protection measures when the product is used in an environment where it is constantly exposed to water or fluids other than water splash. In particular, the product cannot be used in an environment with oil, such as cutting oil or cutting fluid.

● **Enclosure: IP65** Note)

● **Max. stroke: 500 mm***

* For size 32

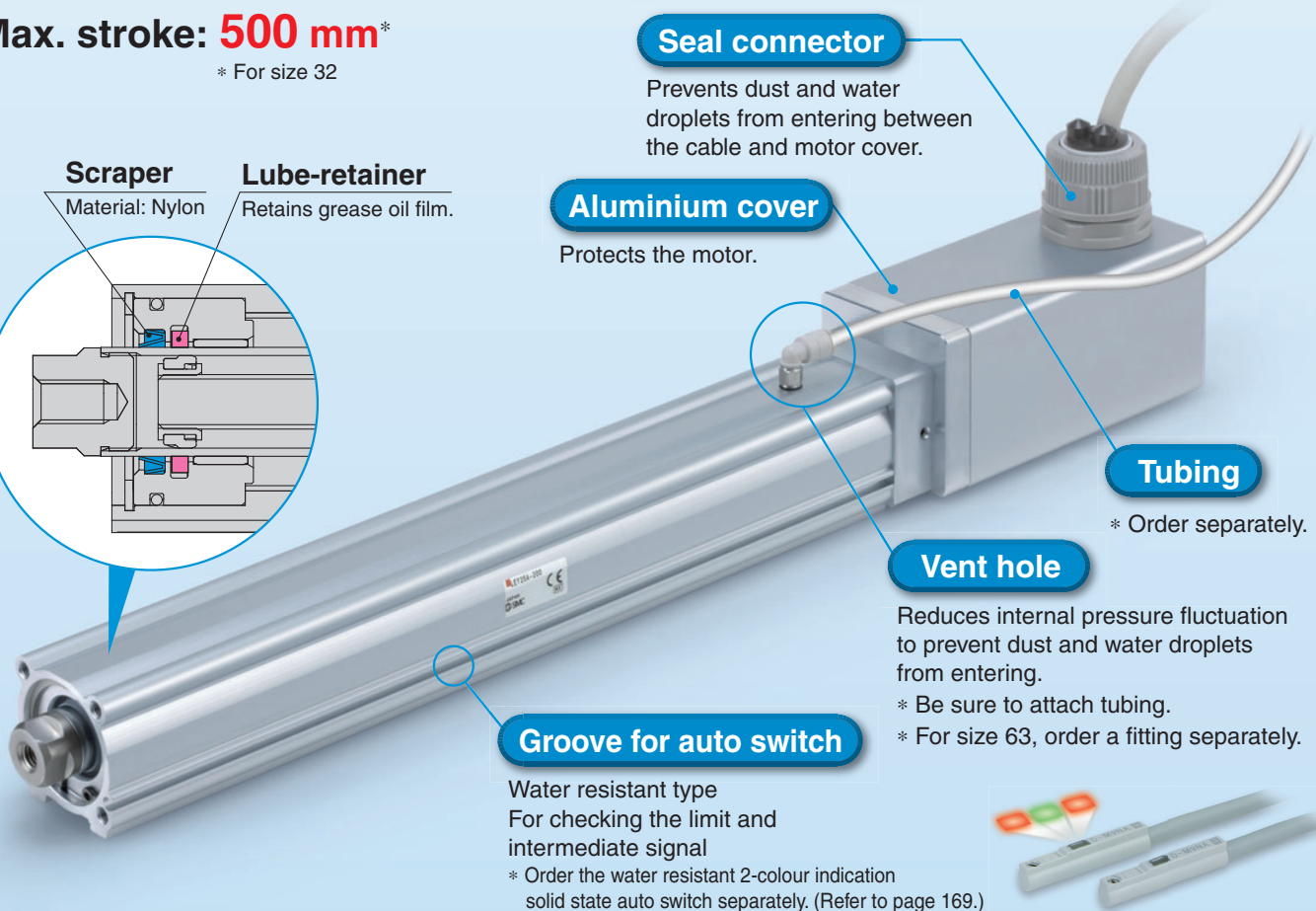
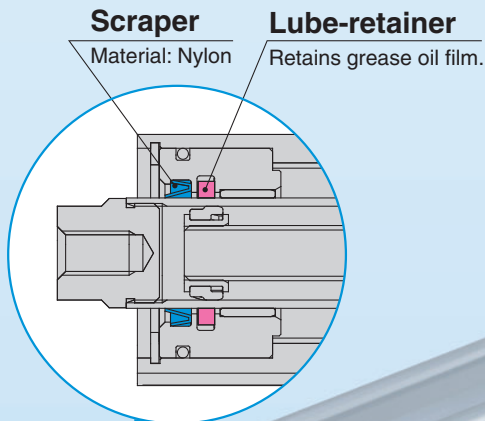

LEY-X5 (Made to Order) (Refer to page 30)

Step Motor (Servo/24 VDC) Type

Servo Motor (24 VDC) Type

Size

25, 32

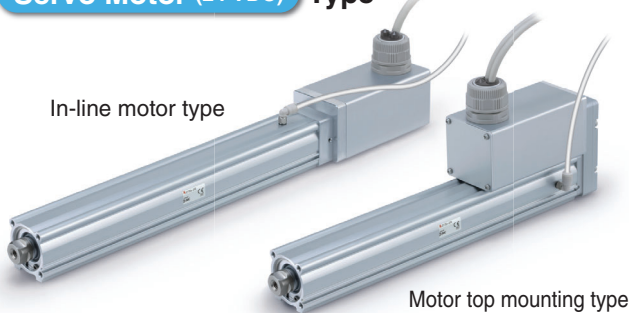

LEY-X5 (Refer to page 150.)

AC Servo Motor (100/200 W) Type

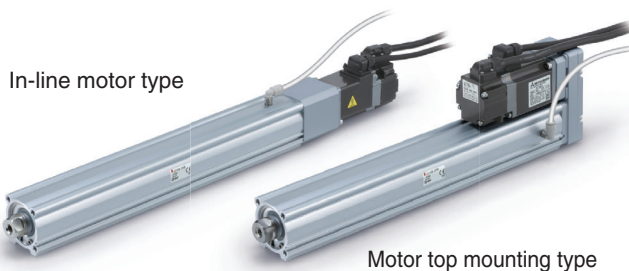

LEY63D□□-□P

(Refer to page 143./Option)

Size

63

AC Servo Motor (400 W) Type

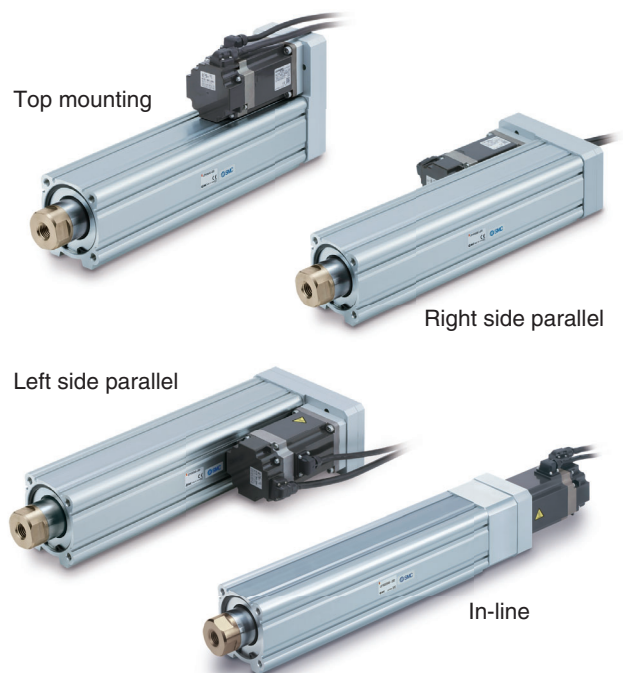

Step Data Input Type Series LECP6/LECA6



Simple Setting to Use Straight Away

Easy Mode for Simple Setting

If you want to use it right away, select "Easy Mode."

Step motor
(Servo/24 VDC)
LECP6

Servo motor
(24 VDC)
LECA6

<When a PC is used> Controller setting software

- Step data setting, test operation, move jog and move for the constant rate can be set and operated on one screen.

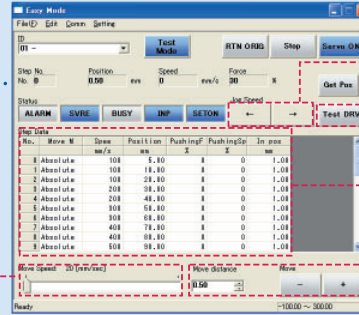
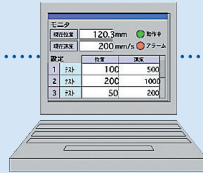

Setting of jog and speed of the constant rate

Move jog

Start testing

Step data setting

Move for the constant rate

<When a TB (teaching box) is used>

- Simple screen without scrolling promotes ease of setting and operating.
- Pick up an icon from the first screen to select a function.
- Set up the step data and check the monitor on the second screen.



Example of setting the step data

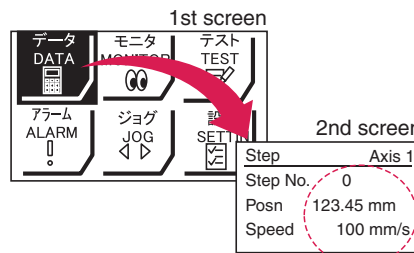

It can be registered by "SET" after entering the values.

Example of checking the operation status

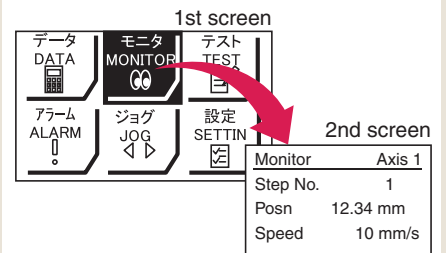

Operation status can be checked.

Fieldbus Network

Fieldbus-compatible Gateway (GW) Unit Series LEC-G

- Conversion unit for Fieldbus network and LEC serial communication
- Two methods of operation
 - Step data input: Operate using preset step data in the controller.
 - Numerical data input: The actuator operates using values such as position and speed from the PLC.
- Values such as position, speed can be checked on the PLC.

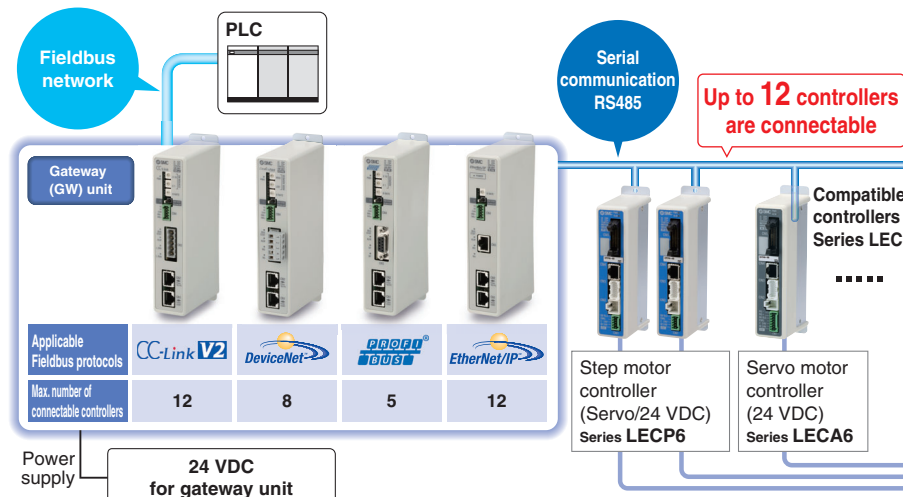

Compatible electric actuators

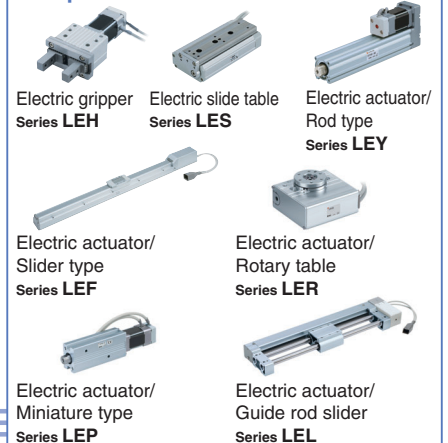

⦿ Normal Mode for Detailed Setting

Select normal mode when detailed setting is required.

- Step data can be set in detail.
- Parameters can be set.
- Signals and terminal status can be monitored.
- JOG and constant rate movement, return to origin, test operation and testing of forced output can be performed.

<When a PC is used> Controller setting software

- Step data setting, parameter setting, monitor, teaching, etc., are indicated in different windows.



Step data setup window

Parameter setup window

Monitoring window

Teaching window

<When a TB (teaching box) is used>

- Multiple step data can be stored in the teaching box, and transferred to the controller.
- Continuous test operation by up to 5 step data.

Teaching box screen

- Each function (step data setting, test, monitor, etc.) can be selected from the main menu.

Main menu screen

Step data setup screen

Test screen

Monitoring screen

The actuator and controller are provided as a set. (They can be ordered separately.)

Confirm that the combination of the controller and the actuator is correct.

<Check the following before use.>

- ① Check the actuator label for model number. This matches the controller.
- ② Check Parallel I/O configuration matches (NPN or PNP).

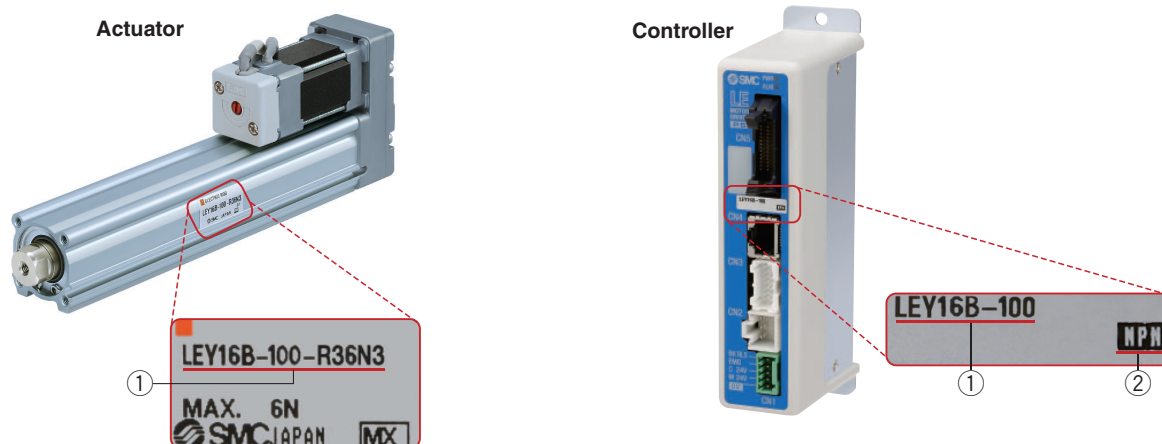

Programless Type *Series LECP1*

No Programming

Capable of setting up an electric actuator operation without using a PC or teaching box



Step motor
(Servo/24 VDC)
LECP1

- ① **Setting position number** → Setting a registered number for the stop position
Maximum 14 points
- ② **Setting a stop position** → Moving the actuator to a stop position using FORWARD and REVERSE buttons
- ③ **Registration** → Registering the stop position using SET button

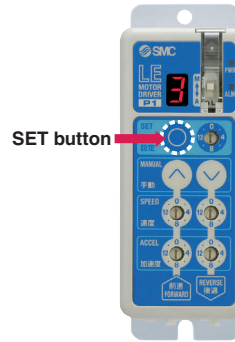
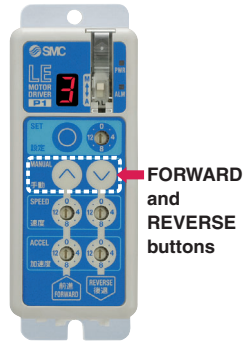
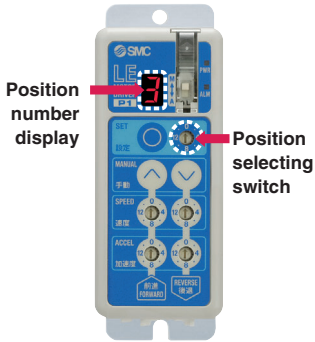

Speed/Acceleration 16-level adjustment

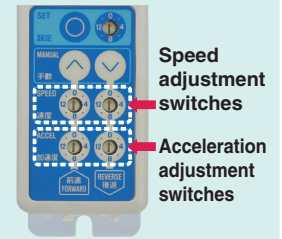

Pulse Input Type *Series LECPA*

- A driver that uses pulse signals to allow positioning at any position. The actuator can be controlled from the customers' positioning unit.

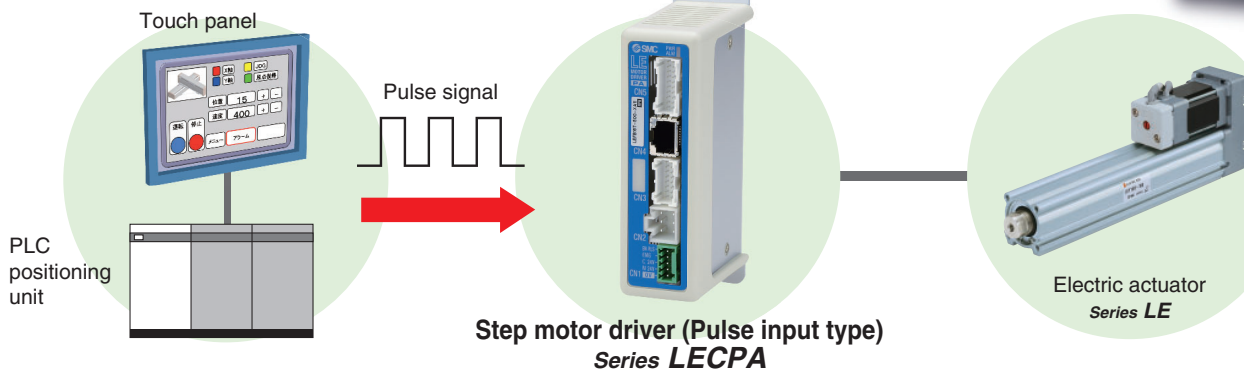

- **Return-to-origin command signal**
Enables automatic return-to-origin action.
- **With force limit function (Pushing force/Gripping force operation available)**
Pushing force/Positioning operation possible by switching signals.

Function

Item	Step data input type LECP6/LECA6	Programless type LECP1	Pulse input type LECPA
Step data and parameter setting	<ul style="list-style-type: none"> Input from controller setting software (PC) Input from teaching box 	<ul style="list-style-type: none"> Select using controller operation buttons 	<ul style="list-style-type: none"> Input from controller setting software (PC) Input from teaching box
Step data "position" setting	<ul style="list-style-type: none"> Input the numerical value from controller setting software (PC) or teaching box Input the numerical value Direct teaching JOG teaching 	<ul style="list-style-type: none"> Direct teaching JOG teaching 	<ul style="list-style-type: none"> No "Position" setting required Position and speed set by pulse signal
Number of step data	64 points	14 points	—
Operation command (I/O signal)	Step No. [IN*] input ⇒ [DRIVE] input	Step No. [IN*] input only	Pulse signal
Completion signal	[INP] output	[OUT*] output	[INP] output

Setting Items

TB: Teaching box PC: Controller setting software

Item	Contents	Easy mode		Normal mode	Step data input type LECP6/LECA6	Pulse input type LECPA	Programless type LECP1*	
		TB	PC	TB·PC				
Step data setting (Excerpt)	Movement MOD	Selection of "absolute position" and "relative position"		△ ●	Set at ABS/INC	No setting required	Fixed value (ABS)	
	Speed	Transfer speed		● ● ●	Set in units of 1 mm/s		Select from 16-level	
	Position	[Position]: Target position [Pushing]: Pushing start position		● ● ●	Set in units of 0.01 mm		Direct teaching JOG teaching	
	Acceleration/Deceleration	Acceleration/deceleration during movement		● ● ●	Set in units of 1 mm/s ²		Select from 16-level	
	Pushing force	Rate of force during pushing operation		● ● ●	Set in units of 1 %		Set in units of 1 %	Select from 3-level (weak, medium, strong)
	Trigger LV	Target force during pushing operation		△ ● ●	Set in units of 1 %		Set in units of 1 %	No setting required (same value as pushing force)
	Pushing speed	Speed during pushing operation		△ ● ●	Set in units of 1 mm/s		Set in units of 1 mm/s	No setting required
	Moving force	Force during positioning operation		△ ● ●	Set to 100 %		Set to (Different values for each actuator) %	
	Area output	Conditions for area output signal to turn ON		△ ● ●	Set in units of 0.01 mm		Set in units of 0.01 mm	
In position	[Position]: Width to the target position [Pushing]: How much it moves during pushing		△ ● ●	Set to 0.5 mm or more (Units: 0.01 mm)	Set to (Different values for each actuator) or more (Units: 0.01 mm)			
Parameter setting (Excerpt)	Stroke (+)	+ side limit of position		× × ●	Set in units of 0.01 mm	Set in units of 0.01 mm	Compatible	
	Stroke (-)	- side limit of position		× × ●	Set in units of 0.01 mm	Set in units of 0.01 mm		
	ORIG direction	Direction of the return to origin can be set.		× × ●	Compatible	Compatible		
	ORIG speed	Speed during return to origin		× × ●	Set in units of 1 mm/s	Set in units of 1 mm/s		
	ORIG ACC	Acceleration during return to origin		× × ●	Set in units of 1 mm/s ²	Set in units of 1 mm/s		
Test	JOG			● ● ●	Continuous operation at the set speed can be tested while the switch is being pressed.	Continuous operation at the set speed can be tested while the switch is being pressed.	Hold down MANUAL button (⊕⊖) for uniform sending (speed is specified value)	
	MOVE			× ● ●	Operation at the set distance and speed from the current position can be tested.	Operation at the set distance and speed from the current position can be tested.	Press MANUAL button (⊕⊖) once for sizing operation (speed, sizing amount are specified values)	
	Return to ORIG			● ● ●	Compatible	Compatible	Compatible	
	Test drive	Operation of the specified step data		● ● ● (Continuous operation)	Compatible	Not compatible	Compatible	
	Forced output	ON/OFF of the output terminal can be tested.		× × ●	Compatible	Compatible	Not compatible	
Monitor	DRV mon	Current position, speed, force and the specified step data can be monitored.		● ● ●	Compatible	Compatible		
	In/Out mon	Current ON/OFF status of the input and output terminal can be monitored.		× × ●	Compatible	Compatible		
ALM	Status	Alarm currently being generated can be confirmed.		● ● ●	Compatible	Compatible	Compatible (display alarm group)	
	ALM Log record	Alarm generated in the past can be confirmed.		× × ●	Compatible	Compatible	Not compatible	
File	Save/Load	Step data and parameter can be saved, forwarded and deleted.		× × ●	Compatible	Compatible		
Other	Language	Can be changed to Japanese or English.		● ● ●	Compatible	Compatible		

△: Can be set from TB Ver. 2.** (The version information is displayed on the initial screen)

* Programless type LECP1 cannot be used with the teaching box and controller setting kit.

System Construction/General Purpose I/O

● **Electric actuator/ Rod type**

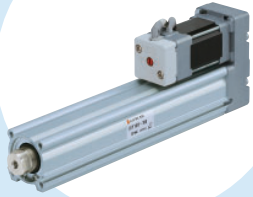

Programless type Page 80
LECP1

Note) The teaching box, controller setting kit and Touch Operator Interface cannot be connected.

Provided by customer
Power supply for controller
24 VDC (Note)

Note) When conformity to UL is required, the electric actuator and controller should be used with a UL1310 Class 2 power supply.

● **Actuator cable*** Pages 71,85

Controller type	Standard cable	Robotic cable
LECP6 (Step data input type)	LE-CP-□-S	LE-CP-□
LECA6 (Step data input type)	—	LE-CA-□
LECP1 (Programless type)	LE-CP-□-S	LE-CP-□

● **Controller*** Page 64

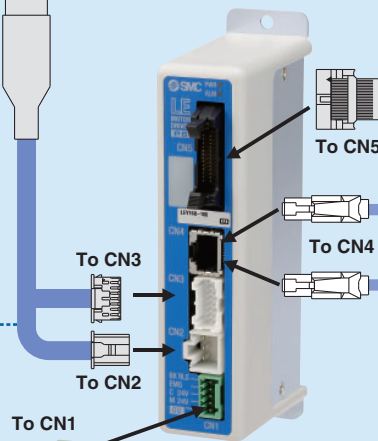

To CN3

To CN2

To CN1

To CN5

To CN4

Step data input type
LECP6/LECA6

● **Power supply plug** Page 65
(Accessory)
<Applicable cable size>
AWG20 (0.5 mm²)

Provided by customer

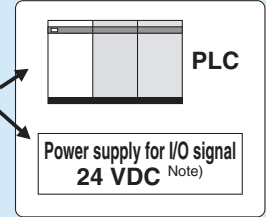

● **I/O cable** Pages 73, 86

Controller type	Part no.
LECP6/LECA6	LEC-CN5-□
LECP1 (Programless)	LEC-CK4-□

● **Touch Operator Interface (Provided by customer)**

GP4501T/GP3500T

Manufactured by Digital Electronics Corp.

Pro-face
for the best interface



Cockpit parts can be downloaded free via the Pro-face website. Using cockpit parts makes adjustment from the Touch Operator Interface possible.

GOT2000 Series

Mitsubishi Electric Corporation

GOT2000
Graphic Operation Terminal



Sample screens for monitoring and changing the current value and the set value of the electric actuator can be downloaded free via the Mitsubishi Electric website.

The * mark: Can be included in the "How to Order" for the actuator.

Options

● **Teaching box** Page 75

(With 3 m cable)
LEC-T1-3EG□



● **Controller setting kit** Page 74

Controller setting kit
(Communication cable, conversion unit and USB cable are included.)
LEC-W2

Or

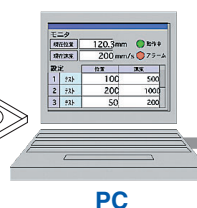

PC

● **Communication cable**
(3 m)

● **USB cable**
(A-mini B type)
(0.3 m)

Note) Cannot be used with the programless type (LECP1).

System Construction/Pulse Signal

● Electric actuator/
Rod type



Page 93

● Current limit resistor
LEC-PA-R-□

* The current limit resistor is used when the pulse signal output of the positioning unit is open collector output.

Provided by customer

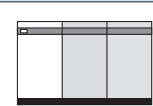

PLC

Power supply for I/O signal
24 VDC
Note)

Note) When conformity to UL is required, the electric actuator and driver should be used with a UL1310 Class 2 power supply.

● Driver* Page 97

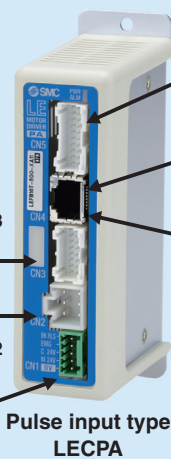

To CN3

To CN2

To CN1

To CN5

To CN4

Pulse input type
LECPA

● I/O cable Page 93

Driver type	Part no.
LECPA	LEC-CL5-□

Provided by customer

Power supply for driver
24 VDC
Note)

Note) When conformity to UL is required, the electric actuator and driver should be used with a UL 1310 Class 2 power supply.

● Power supply plug (Accessory)
<Applicable cable size>
AWG20 (0.5 mm²)

● Actuator cable* Page 92

Driver type	Standard cable	Robotic cable
LECPA (Pulse input type)	LE-CP-□-S	LE-CP-□

The * mark: Can be included in the "How to Order" for the actuator.

Options

● Teaching box Page 95

(With 3 m cable)
LEC-T1-3EG□



● Controller setting software Page 94

Communication cable (With conversion unit) and USB cable are included.
LEC-W2



Communication cable

Or

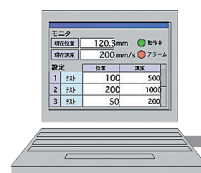

PC

● USB cable
(A-mini B type)

System Construction/Fieldbus Network

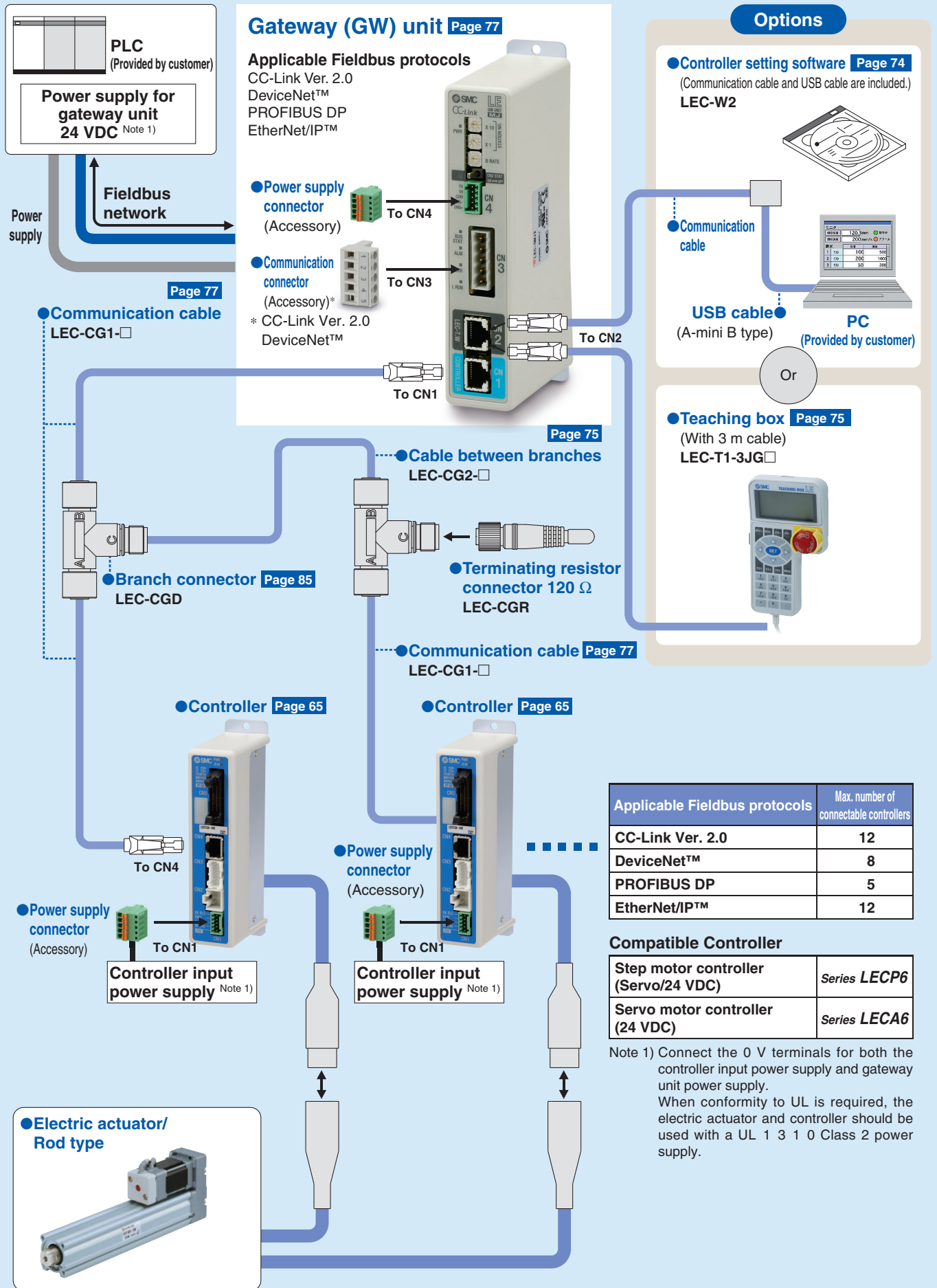

Applicable Fieldbus protocols	Max. number of connectable controllers
CC-Link Ver. 2.0	12
DeviceNet™	8
PROFIBUS DP	5
EtherNet/IP™	12

Compatible Controller





Step motor controller (Servo/24 VDC)	Series LECP6
Servo motor controller (24 VDC)	Series LECA6

Note 1) Connect the 0 V terminals for both the controller input power supply and gateway unit power supply.
When conformity to UL is required, the electric actuator and controller should be used with a UL 1 3 1 0 Class 2 power supply.

AC Servo Motor Driver

Series **LECS** □

Series **LECS** □ List

Series	Compatible motor (100/200 VAC)			Control method			Application/Function	Compatible option	
	100 W	200 W	400 W	Note 1) Positioning	Pulse	Network direct input	Note 2) Synchronous	Setup software MRC2E	
Incremental Type  LECSA (Pulse input type/ Positioning type)	●	●	●	● Up to 7 points	●			●	
	Absolute Type  LECSB (Pulse input type)	●	●	●		●			●
 LECSB (Pulse input type)		●	●	●	● Up to 255 points		● CC-Link Ver. 1.10		●
		 LECSA (Pulse input type/ Positioning type)	●	●	●				
 LECSS (SSCNET III type) Compatible with Mitsubishi Electric's servo system controller network	●	●	●			● SSCNET III	●	●	

Note 1) For positioning type, setting needs to be changed to use with maximum set values. Setup software (MR Configurator2™) LEC-MRC2E is required.

Note 2) Available when the Mitsubishi motion controller is used for the master equipment.

Servo adjustment using auto gain tuning

Auto resonant filter function

- Control the difference between command value and actual action.
- * High-speed positioning is possible since gains etc., are adjusted automatically!

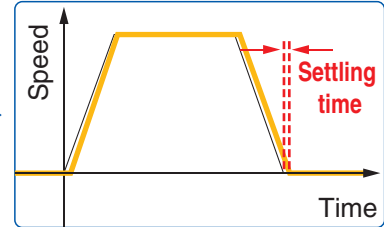
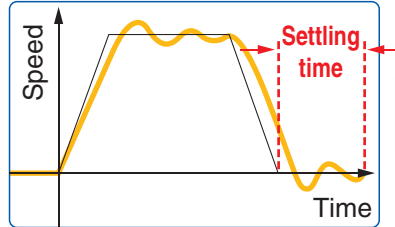

Auto damping control function

- Automatically suppress low frequency machine vibrations (up to 100 Hz).
- * Can be set automatically by auto tuning.

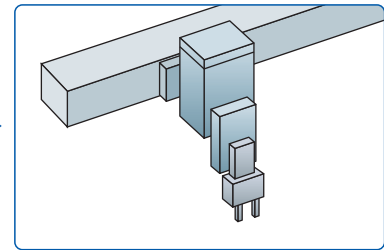
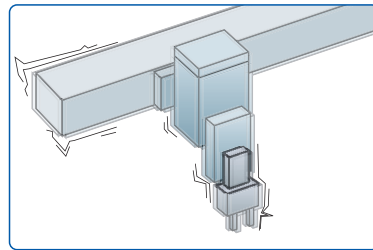

With display setting function

One-touch adjustment button

One-touch servo adjustment

Display

Display the monitor, parameter and alarm.

Settings

Set parameters and monitor display, etc., with push buttons.

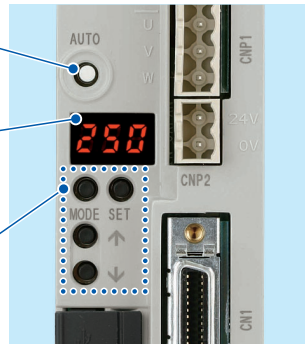

LECSA

Display

Display the monitor, parameter and alarm.

Settings

Set parameters and monitor display, etc., with push buttons.

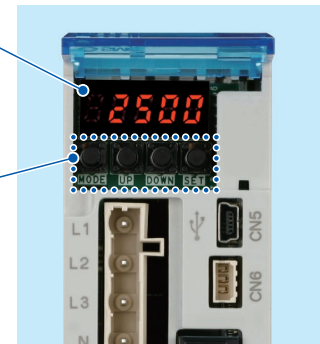

(With the front cover open)

LECSB

Display

Display the communication status with the driver, the alarm and the point table No.

Settings

Control Baud rate, station number and the occupied station count.

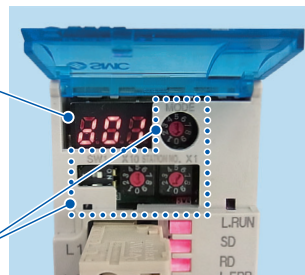

(With the front cover open)

LECSB

Display

Display the communication status with the driver and the alarm.

Settings

Switches for selecting axis and switching to the test operation

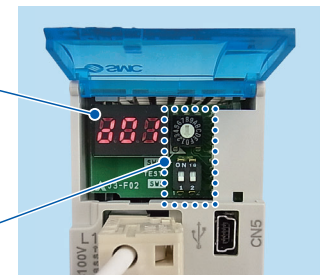

(With the front cover open)

LECSB

System Construction

Incremental encoder compatible **Series LECSA** (Pulse input type/Positioning type)

Provided by customer

Power supply

Single phase 100 to 120 VAC (50/60 Hz)
200 to 230 VAC (50/60 Hz)

Option **Regeneration option**

LEC-MR-RB-□

Motor cable

Standard cable	Robotic cable
LE-CSM-S□□	LE-CSM-R□□

Lock cable

Standard cable	Robotic cable
LE-CSB-S□□	LE-CSB-R□□

Electric actuator

Rod type
Series **LEY**



Guide rod type/
In-line motor type
Series **LEYG**

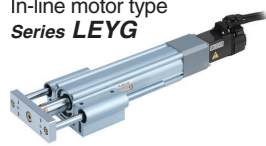

Encoder cable

Standard cable	Robotic cable
LE-CSE-S□□	LE-CSE-R□□

Provided by customer

Control circuit power supply
24 VDC

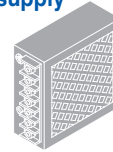

Control circuit power supply connector (Accessory)



Option

Setup software (MR Configurator2™)
LEC-MRC2E

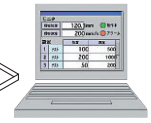

PC

* Order USB cable (LEC-MR-J3USB) separately to use this software.

USB cable LEC-MR-J3USB

Option I/O connector LE-CSNA



Provided by customer

PLC (Positioning unit)

Power supply for I/O signal
24 VDC



Absolute encoder compatible **Series LECSB** (Pulse input type)

Provided by customer

Power supply

Single phase 100 to 120 VAC (50/60 Hz)
200 to 230 VAC (50/60 Hz)

Three phase 200 to 230 VAC (50/60 Hz)

Option **Regeneration option**

LEC-MR-RB-□

Motor cable

Standard cable	Robotic cable
LE-CSM-S□□	LE-CSM-R□□

Lock cable

Standard cable	Robotic cable
LE-CSB-S□□	LE-CSB-R□□

Electric actuator

Rod type
Series **LEY**

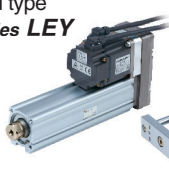

Guide rod type/
In-line motor type
Series **LEYG**

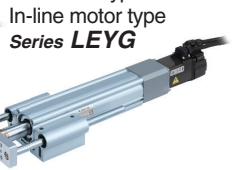

Encoder cable

Standard cable	Robotic cable
LE-CSE-S□□	LE-CSE-R□□

Driver

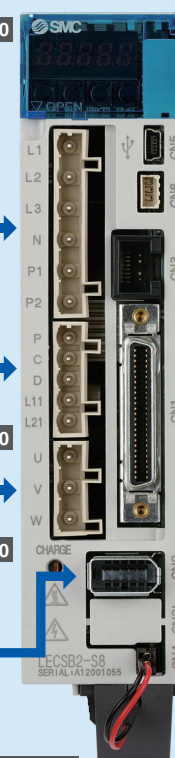

Option USB cable LEC-MR-J3USB



Setup software (MR Configurator2™)
LEC-MRC2E

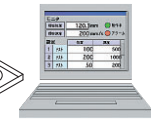

PC

* Order USB cable (LEC-MR-J3USB) separately to use this software.

Analogue monitor output

RS-422 communication



Option I/O connector LE-CSNB

Provided by customer

PLC (Positioning unit)

Power supply for I/O signal
24 VDC

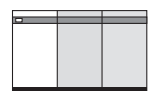

Battery (Accessory) (LEC-MR-J3BAT)

System Construction

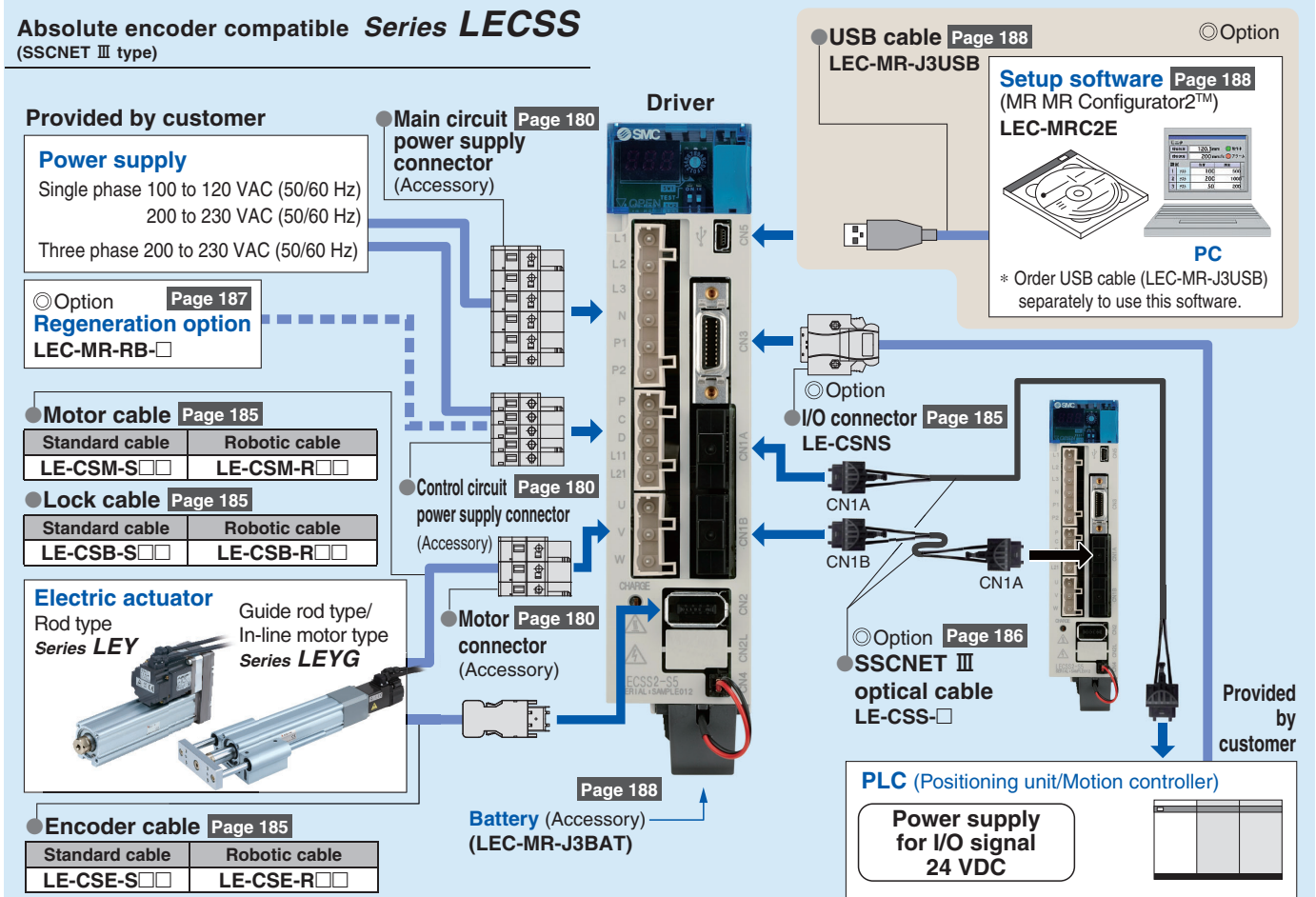
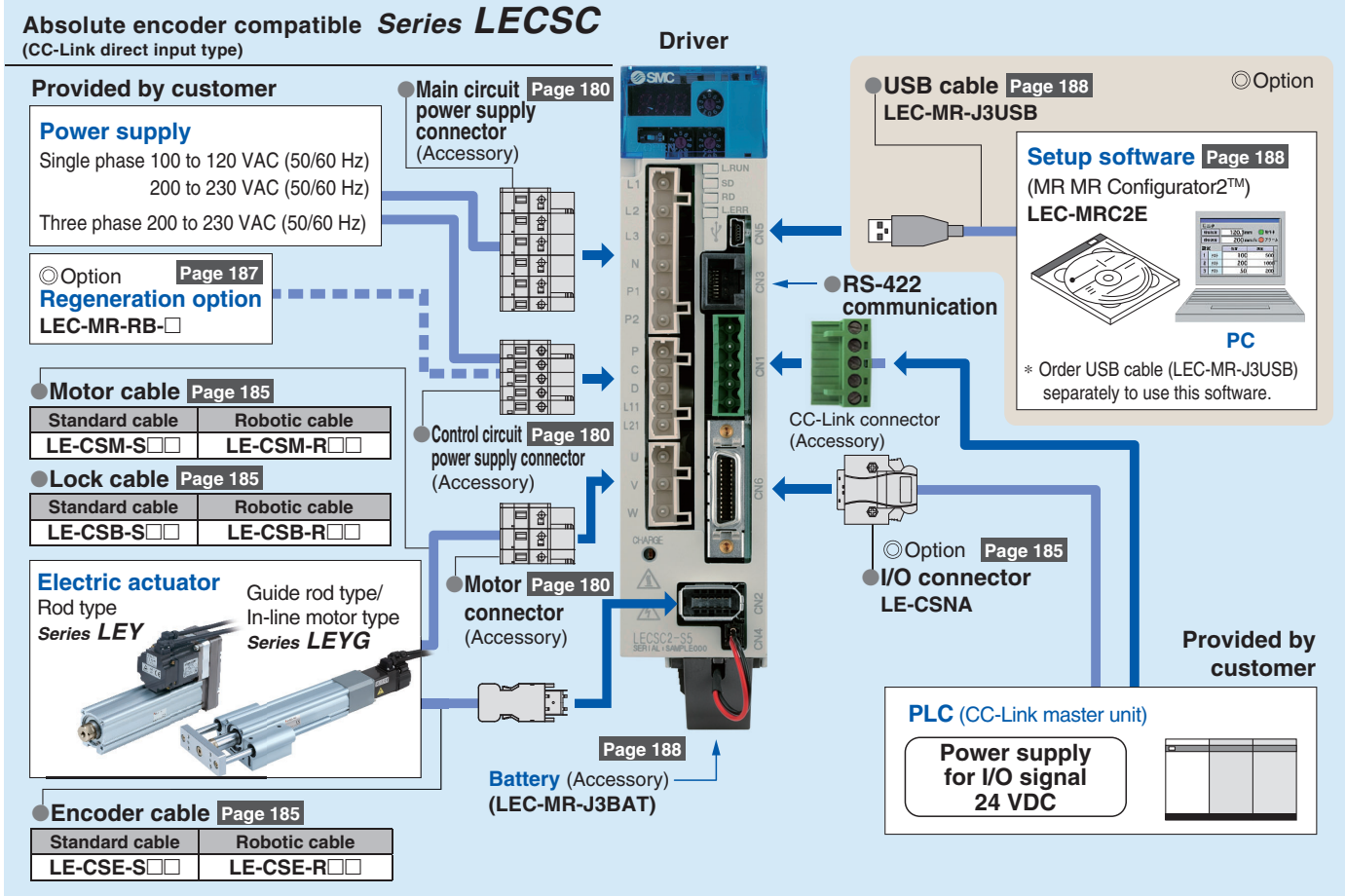

System Construction

Absolute encoder compatible *Series LECSS-T*



Provided by customer

Power supply

Single phase 200 to 240 VAC (50/60 Hz)
Three phase 200 to 240 VAC (50/60 Hz)

◎ Option **Regeneration option**
Page 194
Part no.: **LEC-MR-RB-**□

● **Motor cable** Page 192

Standard cable	Robotic cable
LE-CSM-S□□	LE-CSM-R□□

● **Lock cable** Page 192

Standard cable	Robotic cable
LE-CSB-S□□	LE-CSB-R□□

● **Motor connector** Page 190
(Accessory)

● **Control circuit power supply connector** Page 190
(Accessory)

● **Encoder cable** Page 192

Standard cable	Robotic cable
LE-CSE-S□□	LE-CSE-R□□

● **Main circuit power supply connector** Page 190
(Accessory)

Driver

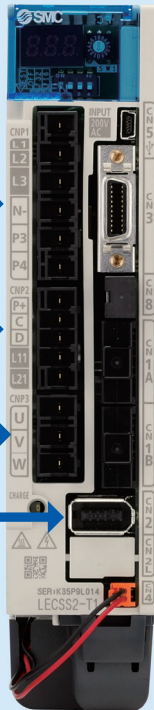

◎ Option

Setup software Page 195
(MR Configurator2™)
Part no.: **LEC-MRC2**□

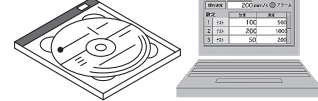

PC

* Order USB cable (LEC-MR-J3USB) separately to use this software.

● **USB cable** Page 196
Part no.: **LEC-MR-J3USB**

◎ Option
● **I/O connector** Page 192
Part no.: **LE-CSNS**

◎ Option
● **STO cable (3 m)** Page 196
Part no.: **LEC-MR-D05UDL3M**

◎ Option Page 193
● **SSCNET III optical cable**
Part no.: **LE-CSS-**□

● **Battery** (Accessory) Page 196
Part no.: **(LEC-MR-BAT6V1SET)**

Provided by customer

PLC

(Positioning unit/Motion controller)

Power supply for I/O signal
24 VDC

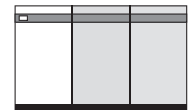

Electric actuator

Slider type
Series LEF

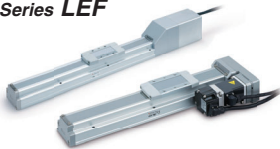

High rigidity slider type
Series LEJ

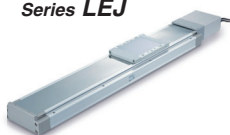

Rod type
Series LEY



Guide rod type
Series LEYG



* The LECSS2-T□ cannot be used with the LEC-MR-SETUP221□.

SMC Electric Actuators

Slider Type Step Motor (Servo/24 VDC) Servo Motor (24 VDC) AC Servo Motor

Ball screw drive
Series LEFS

Clean room compatible



Series LEFS

Size	Max. work load [Kg]	Stroke [mm]
16	10	Up to 400
25	20	Up to 600
32	45	Up to 800
40	60	Up to 1000

Belt drive
Series LEFB



Series LEFB

Size	Max. work load [Kg]	Stroke [mm]
16	1	Up to 1000
25	5	Up to 2000
32	14	Up to 2000

Ball screw drive
Series LEFS

Clean room compatible

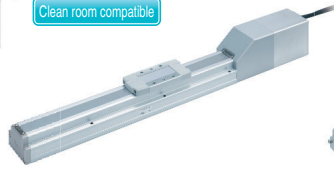

Series LEFS

Size	Max. work load [Kg]	Stroke [mm]
25	20	Up to 600
32	45	Up to 800
40	60	Up to 1000

Belt drive
Series LEFB

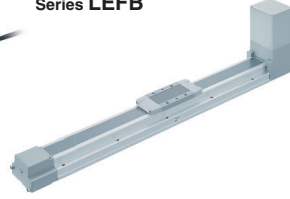

Series LEFB

Size	Max. work load [Kg]	Stroke [mm]
25	5	Up to 2000
32	15	Up to 2500
40	25	Up to 3000

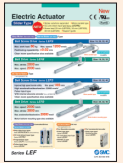

CAT.ES100-87

High Rigidity Slider Type AC Servo Motor

Ball screw drive
Series LEJS

Clean room compatible

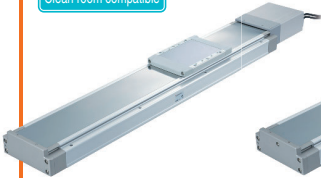

Series LEJS

Size	Max. work load [Kg]	Stroke [mm]
40	55	200 to 1200
63	85	300 to 1500

Belt drive
Series LEJB

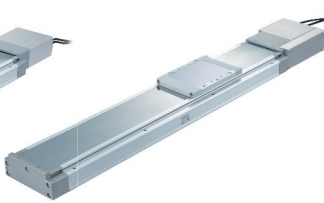

Series LEJB

Size	Max. work load [Kg]	Stroke [mm]
40	20	200 to 2000
63	30	300 to 3000



CAT.ES100-104

Guide Rod Slider Step Motor (Servo/24 VDC)

Belt drive
Series LEL



Series LEL25M
Sliding bearing

Size	Max. work load [Kg]	Stroke [mm]
25	3	Up to 1000

Series LEL25L
Ball bushing bearing

Size	Max. work load [Kg]	Stroke [mm]
25	5	Up to 1000



CAT.E102

Low Profile Slider Type Step Motor (Servo/24 VDC)

Basic type
Series LEMB

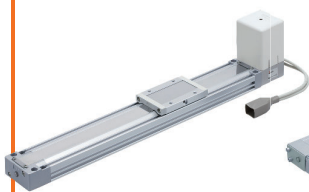

Series LEMB

Size	Max. work load [Kg]	Stroke [mm]
25	6	Up to 2000
32	11	Up to 2000

Cam follower guide type
Series LEMC

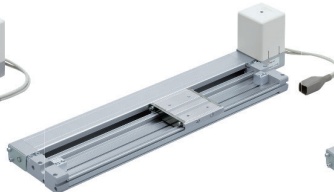

Series LEMC

Size	Max. work load [Kg]	Stroke [mm]
25	10	Up to 2000
32	20	Up to 2000

Linear guide single axis type
Series LEMH

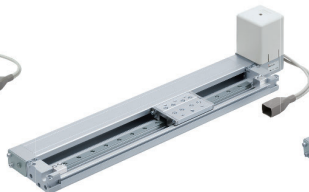

Series LEMH

Size	Max. work load [Kg]	Stroke [mm]
25	10	Up to 1000
32	20	Up to 1500

Linear guide double axis type
Series LEMHT

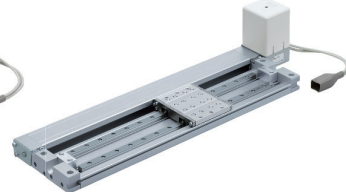

Series LEMHT

Size	Max. work load [Kg]	Stroke [mm]
25	10	Up to 1000
32	20	Up to 1500



CAT.ES100-98

SMC Electric Actuators

Rod Type Step Motor (Servo/24 VDC) Servo Motor (24 VDC)

Basic type Series LEY

Dust/Drip proof compatible



Series LEY

Size	Pushing force [N]	Stroke [mm]
16	141	Up to 300
25	452	Up to 400
32	707	Up to 500
40	1058	Up to 500

In-line motor type Series LEY□D

Dust/Drip proof compatible



Guide rod type Series LEYG

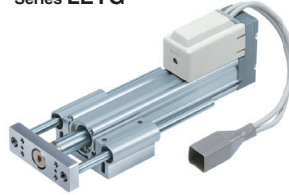

Series LEYG

Size	Pushing force [N]	Stroke [mm]
16	141	Up to 200
25	452	Up to 300
32	707	Up to 300
40	1058	Up to 300

Guide rod type /In-line motor type Series LEYG□D



CAT.E102

AC Servo Motor

Basic type Series LEY

Dust/Drip proof compatible



Series LEY

Size	Pushing force [N]	Stroke [mm]
25	485	Up to 400
32	588	Up to 500

In-line motor type Series LEY□D

Dust/Drip proof compatible



Series LEY

Size	Pushing force [N]	Stroke [mm]
25	485	Up to 400
32	736	Up to 500
63	1910	Up to 800

Guide rod type Series LEYG



Series LEYG

Size	Pushing force [N]	Stroke [mm]
25	485	300
32	588	

Guide rod type /In-line motor type Series LEYG□D

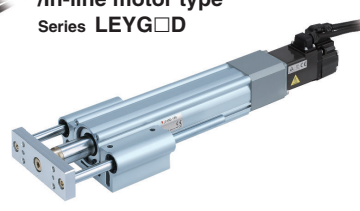

Series LEYG

Size	Pushing force [N]	Stroke [mm]
25	485	300
32	736	

Slide Table Step Motor (Servo/24 VDC) Servo Motor (24 VDC)

Series LES

Basic type/R type Series LES□R



Size	Max. work load [Kg]	Stroke [mm]
8	1	30, 50, 75
16	3	30, 50, 75, 100
25	5	30, 50, 75, 100, 125, 150

Symmetrical type/L type Series LES□L



In-line motor type/D type Series LES□D



Series LESH

Basic type/R type Series LESH□R



Size	Max. work load [Kg]	Stroke [mm]
8	2	50, 75
16	6	50, 100
25	9	50, 100, 150

Symmetrical type/L type Series LESH□L



In-line motor type/D type Series LESH□D



CAT.E102

Miniature Step Motor (Servo/24 VDC)

Rod type Series LEPY



Series LEPY

Size	Max. work load [Kg]	Stroke [mm]
6	1	25, 50, 75
10	2	

Slide table type Series LEPS



Series LEPS

Size	Max. work load [Kg]	Stroke [mm]
6	1	25
10	2	50



CAT.E102

Rotary Table Step Motor (Servo/24 VDC)

Basic type Series LER



Series LER

Size	Rotating torque (N·m)		Max. speed (°/s)	
	Basic	High torque	Basic	High torque
10	0.22	0.32	420	280
30	0.8	1.2		
50	6.6	10		

High precision type Series LERH



CAT.E102

SMC Electric Actuators

Gripper (Step Motor (Servo/24 VDC))

2-finger type
Series LEHZ



Size	Max. gripping force [N]		Stroke/both sides [mm]
	Basic	Compact	
10	14	6	4
16		8	6
20	40	28	10
25		—	14
32	130	—	22
40	210	—	30

2-finger type
With dust cover
Series LEHZJ

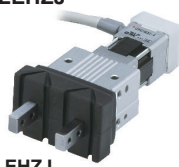

Size	Max. gripping force [N]		Stroke/both sides [mm]
	Basic	Compact	
10	14	6	4
16		8	6
20	40	28	10
25		—	14

2-finger type
Long stroke
Series LEHF



Size	Max. gripping force [N]	Stroke/both sides [mm]	
		Basic	Compact
10	7	16 (32)	
20	28	24 (48)	
32	120	32 (64)	
40	180	40 (80)	

Note) (): Long stroke

3-finger type
Series LEHS

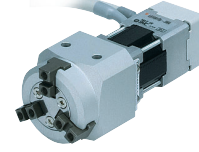

Size	Max. gripping force [N]		Stroke/diameter [mm]
	Basic	Compact	
10	5.5	3.5	4
20	22	17	6
32	90	—	8
40	130	—	12



Controllers/Driver

Step Motor (Servo/24 VDC)

Servo Motor (24 VDC)

Step Data Input Type

Series LECP6
Series LECA6

- 64 points positioning
- Input using controller setting kit or teaching box



4-Axis Controller

Step Data Input Type

Series JXC73/83



Step Motor (Servo/24 VDC)

Programless Type

Series LECP1

- 14 points positioning
- Control panel setting (PC is not required.)



Programless Type
(With Stroke Study)

Series LECP2

- End to end operation similar to an air cylinder
- 2 stroke end points + 12 intermediate points positioning



Specialized for Series LEM

Step Motor (Servo/24 VDC)

Pulse Input Type

Series LECPA



Fieldbus-compatible Network Controller/Gateway Unit

Series JXC□1

PROFIBUS
EtherCAT
DeviceNet
EtherNet/IP
IO-Link



Series JXC92

EtherNet/IP



Series JXC93

EtherNet/IP



Series LEC-G

PROFIBUS
CC-Link V2
DeviceNet
EtherNet/IP



AC Servo Motor

Pulse Input Type

Series LECSA

Series LECSB

- Absolute encoder (LECSB)
- Built-in positioning function (LECSA)



Series LECSA Series LECSB

CC-Link
Direct Input Type
Series LECSA
CC-Link



SSCNET III Type
Series LECSA

SSCNET III
SERVO SYSTEM CONTROLLER NETWORK



MECHATROLINK II Type
Series LECYM

MECHATROLINK-II



MECHATROLINK III Type
Series LECYU

MECHATROLINK-III



SSCNET III/H Type
Series LECSS-T

SSCNET III/H
SERVO SYSTEM CONTROLLER NETWORK



Series Variations

Electric Actuator **Rod Type** Series **LEY**

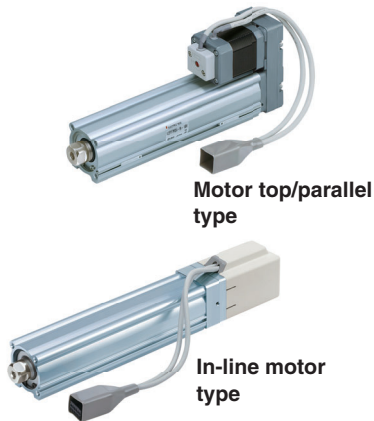

Specifications	Series	Stroke [mm]	Pushing force [N]	Vertical work load [kg]	Speed [mm/s]	Screw lead [mm]	Positioning repeatability [mm]	Controller /Driver series	Reference page	
Step motor (Servo/24 VDC)	LEY16□	30 to 300	38	2	15 to 500	10	±0.02 or less	Series LECP6	Page 3	
			74	4	8 to 250	5				
			141	8	4 to 125	2.5				
	LEY25□	30 to 400	122	8	18 to 500	12				Series LECP1
			238	16	9 to 250	6				
			452	30	5 to 125	3				
	LEY32□	30 to 500	189	11	24 to 500	16		Series LECPA		
			370	22	12 to 250	8				
			707	43	6 to 125	4				
	LEY40□	30 to 500	283	13	24 to 300	16				Series LECA6
			553	27	12 to 150	8				
			1058	53	6 to 75	4				
Servo motor (24 VDC)	LEY16□A	50 to 300	30	2	15 to 500	10	Series LECA6			
			58	4	8 to 250	5				
			111	8	4 to 125	2.5				
	LEY25□A	50 to 400	35	3	18 to 500	12				
			72	6	9 to 250	6				
			130	12	5 to 125	3				

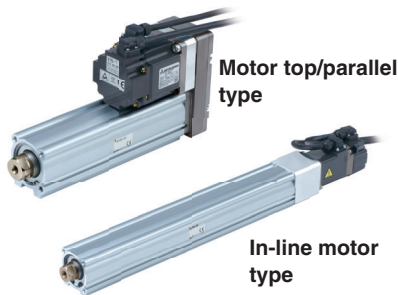

Specifications	Series	Stroke [mm]	Pushing force [N]	Vertical work load [kg]	Speed [mm/s]	Screw lead [mm]	Positioning repeatability [mm]	Driver series	Reference page
AC servo motor	LEY25□S	30 to 400	131	8	900	12	±0.02 or less	Series LECSA Series LECSB Series LECSA Series LECSA	Page 127
			255	16	450	6			
			485	30	225	3			
	LEY32□S	30 to 500	157 (197)	9 (12)	1200 (1000)	20 (16)			
			308 (385)	19 (24)	600 (500)	10 (8)			
			588 (736)	37 (46)	300 (250)	5 (4)			
	LEY63□S	100 to 800	521	19	1000	20			
			1012	38	500	10			
			1910	72	250	5			

The values shown in (): In-line motor type

Controller/Driver **LEC**



Type	Series	Compatible motor	Power supply voltage	Parallel I/O		Number of positioning pattern points	Reference page
				Input	Output		
Step data input type	LECP6	Step motor (Servo/24 VDC)	24 VDC ±10 %	11 inputs (Photo-coupler isolation)	13 outputs (Photo-coupler isolation)	64	Page 64
	LECA6	Servo motor (24 VDC)					
Programless type	LECP1	Step motor (Servo/24 VDC)	24 VDC ±10 %	6 inputs (Photo-coupler isolation)	6 outputs (Photo-coupler isolation)	14	
Pulse input type	LECPA	Step motor (Servo/24 VDC)	24 VDC ±10 %	5 inputs (Photo-coupler isolation)	9 outputs (Photo-coupler isolation)	—	

Series Variations

Electric Actuator **Guide Rod Type** Series **LEYG**

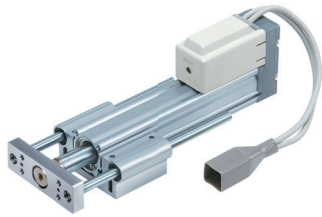

Motor top mounting type



In-line motor type



Guide rod type

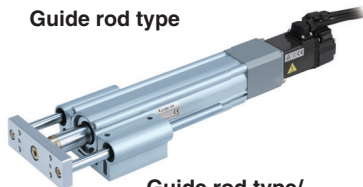

Guide rod type/
In-line motor type

Specifications	Series	Stroke [mm]	Pushing force [N]	Vertical work load [kg]	Speed [mm/s]	Screw lead [mm]	Controller /Driver series	Reference page
Step motor (Servo/24 VDC)	LEYG16□	30 to 200	38	1.5	15 to 500	10	Series LECP6 Series LECP1 Series LECPA	Page 40
			74	3.5	8 to 250	5		
			141	7.5	4 to 125	2.5		
	LEYG25□	30 to 300	122	7	18 to 500	12		
			238	15	9 to 250	6		
	LEYG32□	30 to 300	452	29	5 to 125	3		
			189	9	24 to 500	16		
	LEYG40□	30 to 300	370	20	12 to 250	8		
			707	41	6 to 125	4		
			283	11	24 to 300	16		
553			25	12 to 150	8			
Servo motor (24 VDC)	LEYG16□A	30 to 200	1058	51	6 to 75	4	Series LECA6	
			30	1.5	15 to 500	10		
			58	3.5	8 to 250	5		
	LEYG25□A	30 to 300	111	7.5	4 to 125	2.5		
			35	2	18 to 500	12		
			72	5	9 to 250	6		
			130	11	5 to 125	3		

Specifications	Series	Stroke [mm]	Pushing force [N]	Vertical work load [kg]	Speed [mm/s]	Screw lead [mm]	Positioning repeatability [mm]	Driver series	Reference page
AC servo motor	LEYG25□S	30 to 300	131	7	900	12	±0.02 or less	Series LECSA Series LECSB Series LECSA Series LECSB Series LECSA Series LECSB	Page 157
			255	15	450	6			
			485	29	225	3			
	LEYG32□S	30 to 300	157 (197)	7 (10)	1200 (1000)	20 (16)			
			308 (385)	17 (22)	600 (500)	10 (8)			
			588 (736)	35 (44)	300 (250)	5 (4)			

The values shown in () : In-line motor type

Driver **LEC**



LECSA



LECSB



LECSA



LECSB

Type	Series	Compatible motor	Power supply voltage	Parallel I/O		Number of positioning pattern points	Reference page
				Input	Output		
Pulse input type (For incremental encoder)	LECSA	AC servo motor (100/200/400 W)	100 to 120 VAC (50/60 Hz) 200 to 230 VAC (50/60 Hz)	6 inputs (Photo-coupler isolation)	4 outputs (Photo-coupler isolation)	7	Page 173
Pulse input type (For absolute encoder)	LECSB			10 inputs (Photo-coupler isolation)	6 outputs (Photo-coupler isolation)	—	
CC-Link direct input type (For absolute encoder)	LECSA			4 inputs (Photo-coupler isolation)	3 outputs (Photo-coupler isolation)	255	
SSCNET III type (For absolute encoder)	LECSB			4 inputs (Photo-coupler isolation)	3 outputs (Photo-coupler isolation)	—	

INDEX

Step Motor (Servo/24 VDC)/ Servo Motor (24 VDC) Type

◎Rod Type Series LEY

Model Selection	Page 3
How to Order	Page 13
Specifications	Page 15
Construction	Page 17
Dimensions	Page 19
Accessory Mounting Brackets	Page 25
Auto Switch	Page 27

◎Rod Type Series LEY-X5 **Dust/Drip proof (IP65 equivalent)**

Model Selection	Page 9
How to Order	Page 30
Specifications	Page 31
Construction	Page 33
Dimensions	Page 34
Auto Switch	Page 36

◎Rod Type Series 25A-LEY **Secondary Batteries Compatible**

How to Order	Page 37
Specific Product Precautions	Page 39

◎Guide Rod Type Series LEYG

Model Selection	Page 40
How to Order	Page 47
Specifications	Page 49
Construction	Page 51
Dimensions	Page 53
Support Block	Page 57
Specific Product Precautions	Page 59

◎Step Motor (Servo/24 VDC)/Servo Motor (24 VDC) Controller/Driver

Step Data Input Type/Series LECP6/LECA6	Page 65
Controller Setting Kit/ LEC-W2	Page 74
Teaching Box/ LEC-T1	Page 75
Gateway Unit/Series LEC-G	Page 77
Programless Controller/Series LECP1	Page 80
Step Motor Driver/Series LECPA	Page 87
Controller Setting Kit/ LEC-W2	Page 94
Teaching Box/ LEC-T1	Page 95
Direct Input Type Controller/Series JXC□1	Page 99
Multi-Axis Step Motor Controller/Series JXC73/83/92/93	Page 108

AC Servo Motor Type

◎Rod Type Series LEY **Size 25, 32**

Model Selection	Page 127
How to Order	Page 133
Specifications	Page 135
Construction	Page 136
Dimensions	Page 137

◎Rod Type Series LEY **Size 63**

Dust/Drip proof (IP65 equivalent) (Select options)

Model Selection	Page 127
How to Order	Page 143
Specifications	Page 144
Construction	Page 145
Dimensions	Page 146

◎Rod Type Series LEY-X5 **Dust/Drip proof (IP65 equivalent)**

Model Selection	Page 127
How to Order	Page 150
Specifications	Page 151
Construction	Page 152
Dimensions	Page 153

◎Rod Type Series 25A-LEY **Secondary Batteries Compatible**

How to Order	Page 155
Specific Product Precautions	Page 39

◎Guide Rod Type Series LEYG

Model Selection	Page 157
How to Order	Page 161
Specifications	Page 163
Construction	Page 165
Dimensions	Page 166
Support Block	Page 168
Specific Product Precautions	Page 169

◎AC Servo Motor Driver/Series **LECS□**

Page 173	
Specific Product Precautions	Page 197

◎AC Servo Motor Driver/Series **LECSS-T**

Page 189

◎AC Servo Motor Driver/Series **LECY□**

Page 200

Step Motor (Servo/24 VDC)

Servo Motor (24 VDC)

Rod Type **Page 3**

Series LEY

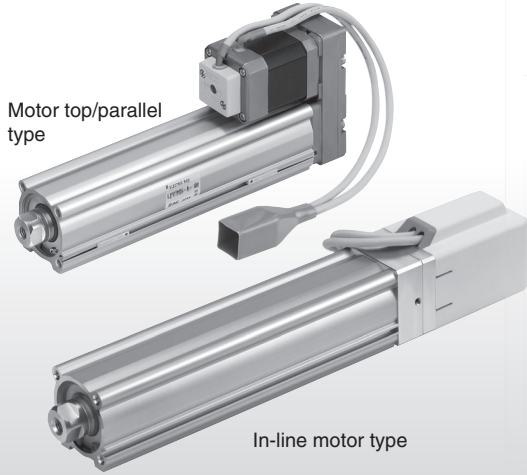

Dust/Drip proof (IP65 equivalent) **Page 30**

Series LEY-X5

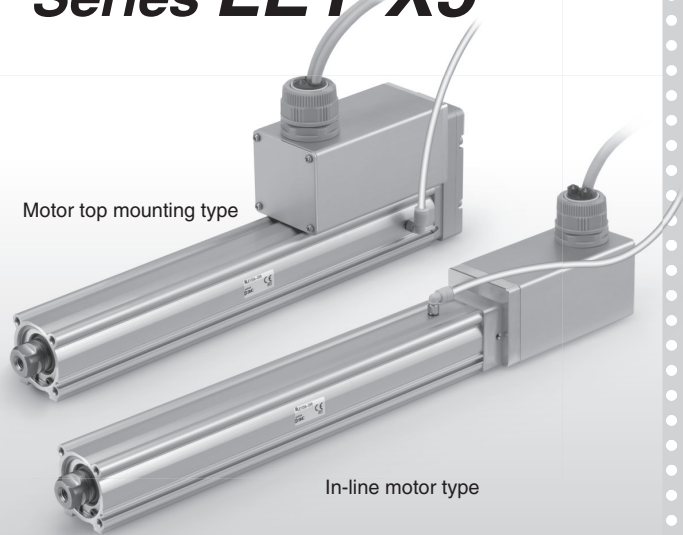

Rod Type **Page 37**

Secondary Batteries Compatible

Series 25A-LEY

Motor top mounting type

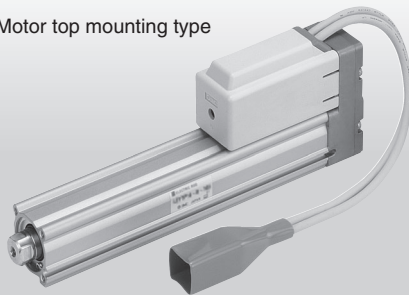

Guide Rod Type **Page 40**

Series LEYG

Motor top mounting type

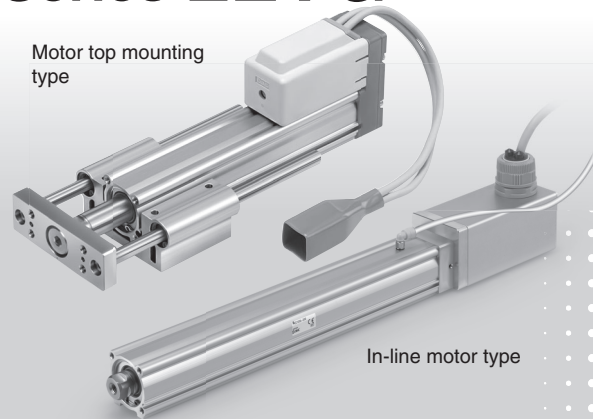

Step Motor/Servo Motor Controller **Page 64**
Step Motor Driver

Series **LECP6/LECA6**

Series **LEC-G**

Series **LECP1**

Series **LECPA**

Series **JXC□1**

Series **JXC73/83/92/93**



Series LEY

Model Selection



Selection Procedure

Positioning Control Selection Procedure



Selection Example

Operating conditions

- Workpiece mass: 4 [kg]
- Speed: 100 [mm/s]
- Acceleration/Deceleration: 3,000 [mm/s²]
- Stroke: 200 [mm]
- Workpiece mounting condition: Vertical upward downward transfer

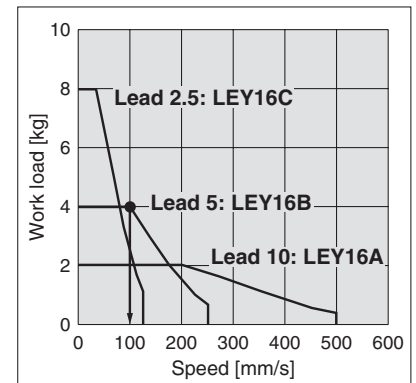

<Speed-Vertical work load graph> (LEY16/Step motor)

Step 1 Check the work load-speed. <Speed-Vertical work load graph>

Select the target model based on the workpiece mass and speed with reference to the <Speed-Vertical work load graph>.

Selection example) The **LEY16B** is temporarily selected based on the graph shown on the right side.

* It is necessary to mount a guide outside the actuator when used for horizontal transfer. When selecting the target model, refer to page 15 for the horizontal work load in the specifications, and page 59 for the precautions.

Step 2 Check the cycle time.

Calculate the cycle time using the following calculation method.

- Cycle time T can be found from the following equation.

$$T = T1 + T2 + T3 + T4 \text{ [s]}$$

- T1: Acceleration time and T3: Deceleration time can be obtained by the following equation.

$$T1 = V/a1 \text{ [s]} \quad T3 = V/a2 \text{ [s]}$$

- T2: Constant speed time can be found from the following equation.

$$T2 = \frac{L - 0.5 \cdot V \cdot (T1 + T3)}{V} \text{ [s]}$$

- T4: Settling time varies depending on the conditions such as motor types, load and in positioning of the step data. Therefore, please calculate the settling time with reference to the following value.

$$T4 = 0.2 \text{ [s]}$$

Calculation example)

T1 to T4 can be calculated as follows.

$$T1 = V/a1 = 100/3000 = 0.033 \text{ [s]}, \quad T3 = V/a2 = 100/3000 = 0.033 \text{ [s]}$$

$$T2 = \frac{L - 0.5 \cdot V \cdot (T1 + T3)}{V} = \frac{200 - 0.5 \cdot 100 \cdot (0.033 + 0.033)}{100} = 1.97 \text{ [s]}$$

$$T4 = 0.2 \text{ [s]}$$

Therefore, the cycle time can be obtained as follows.

$$T = T1 + T2 + T3 + T4 = 0.033 + 1.967 + 0.033 + 0.2 = 2.233 \text{ [s]}$$

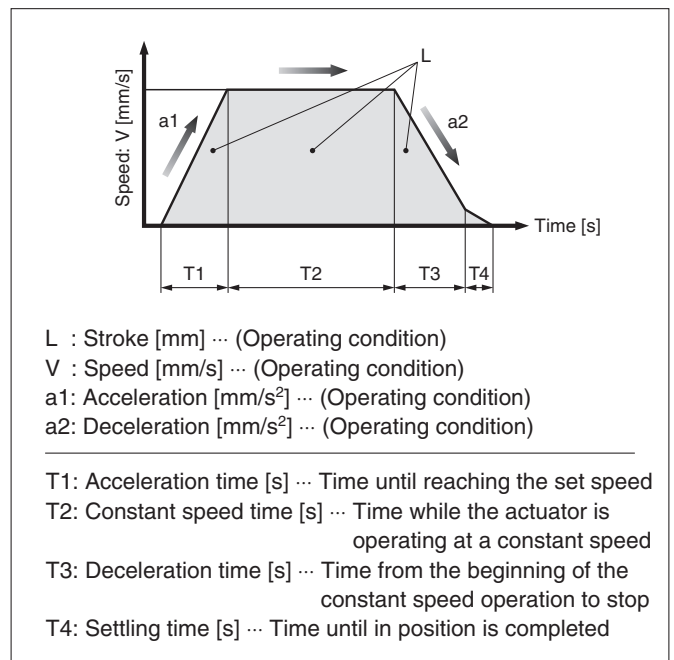

Based on the above calculation result, the **LEY16B-200** is selected.

Pushing Control Selection Procedure



* The duty ratio is a ratio at the time that can keep being pushed.

Selection Example

Operating conditions

- Mounting condition: Horizontal (pushing)
- Jig weight: 0.2 [kg]
- Pushing force: 60 [N]
- Duty ratio: 20 [%]
- Speed: 100 [mm/s]
- Stroke: 200 [mm]

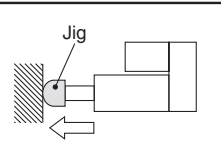

Step 1 Check the duty ratio.

<Conversion table of pushing force–duty ratio>

Select the [Pushing force] from the duty ratio with reference to the <Conversion table of pushing force–duty ratio>.

Selection example)

Based on the table below,

- Duty ratio: 20 [%]

Therefore, the set value of pushing force will be 70 [%].

<Conversion table of pushing force–duty ratio> (LEY16/Step motor)

Set value of pushing force [%]	Duty ratio (%)	Continuous pushing time (minute)
40 or less	100	—
50	70	12
70	20	1.3
85	15	0.8

* [Set value of pushing force] is one of the step data input to the controller.

* [Continuous pushing time] is the time that the actuator can continuously keep pushing.

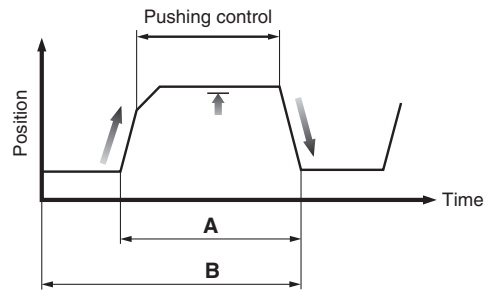

Duty ratio = A/B x 100 [%]

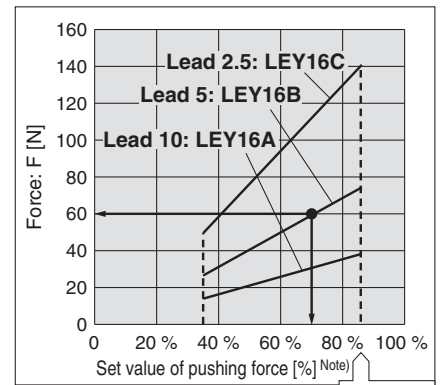

<Force conversion graph> (LEY16/Step motor)

Note) Set values for the controller.

Step 2 Check the pushing force. <Force conversion graph>

Select the target model based on the set value of pushing force and force with reference to the <Force conversion graph>.

Selection example)

Based on the graph shown on the right side,

- Set value of pushing force: 70 [%]
- Pushing force: 60 [N]

Therefore, the **LEY16B** is temporarily selected.

Step 3 Check the lateral load on the rod end.

<Graph of allowable lateral load on the rod end>

Confirm the allowable lateral load on the rod end of the actuator: LEY16□, which has been selected temporarily with reference to the <Graph of allowable lateral load on the rod end>.

Selection example)

Based on the graph shown on the right side,

- Jig weight: 0.2 [kg] ≈ 2 [N]
- Product stroke: 200 [mm]

Therefore, the lateral load on the rod end is in the allowable range.

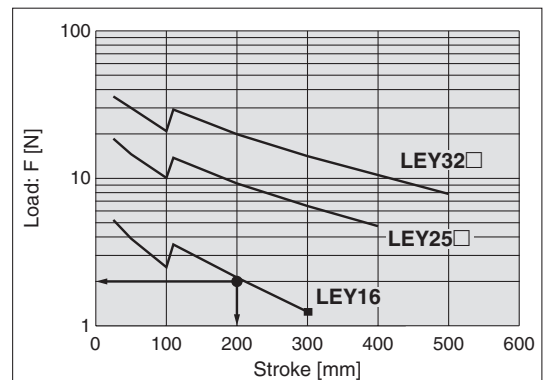

<Graph of allowable lateral load on the rod end>

Based on the above calculation result, the LEY16B-200 is selected.

LEY

LEYG

LECA6
LECP6

LEC-G

LECP1

LECPA

JXC□1

JXC7/3/3/3/2/3/3

LEY

LEYG

AC Servo Motor

LECS□

LECS-T

LECY□

Specific Product Precautions

Series LEY

Step Motor (Servo/24 VDC) Servo Motor (24 VDC)

Speed-Work Load Graph (Guide)

For Step Motor (Servo/24 VDC) LECP6, LECP1, JXCE1/91/P1/D1/L1

Horizontal

LEY16  for acceleration/deceleration: 2000 mm/s²

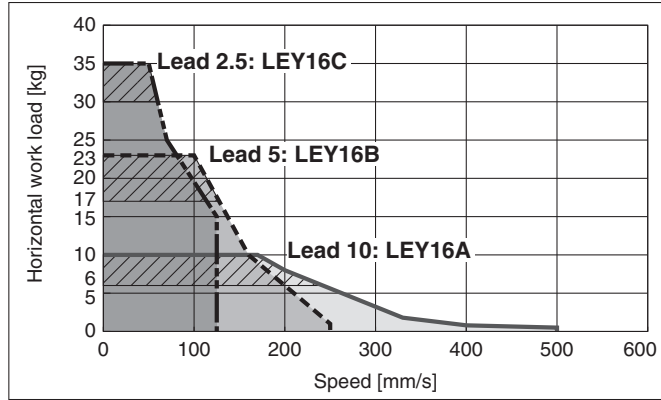

LEY25  for acceleration/deceleration: 2000 mm/s²

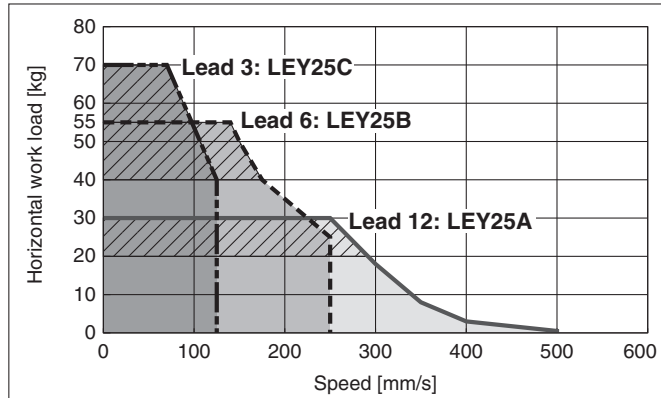

LEY32  for acceleration/deceleration: 2000 mm/s²

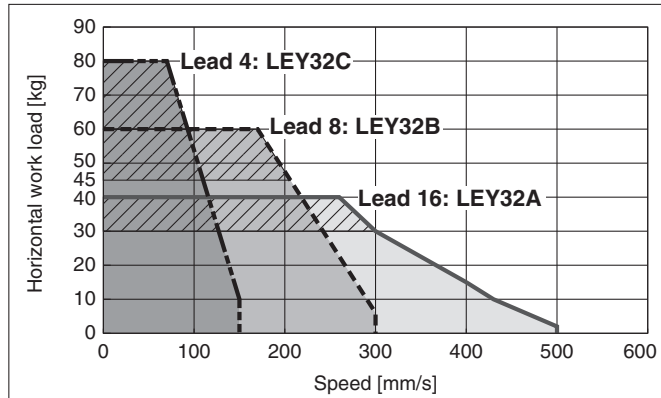

LEY40  for acceleration/deceleration: 2000 mm/s²

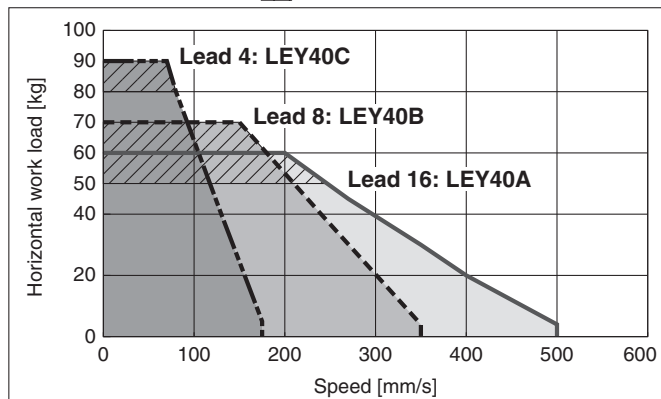

Vertical

LEY16 

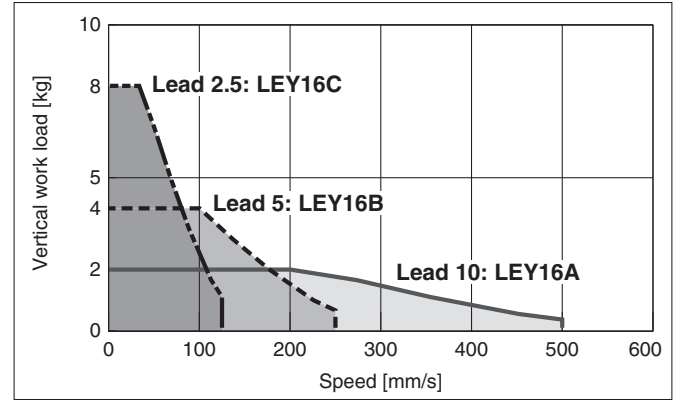

LEY25 

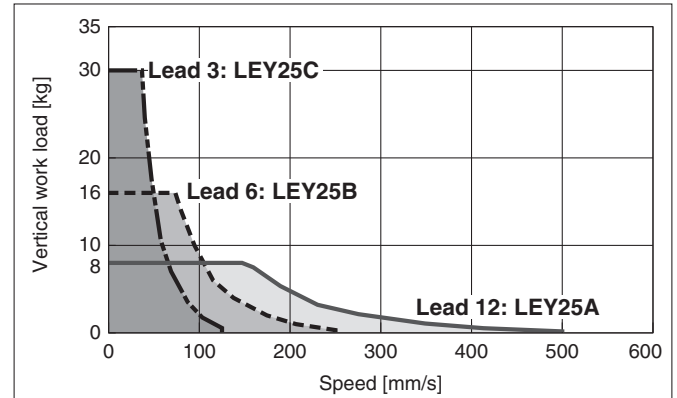

LEY32 

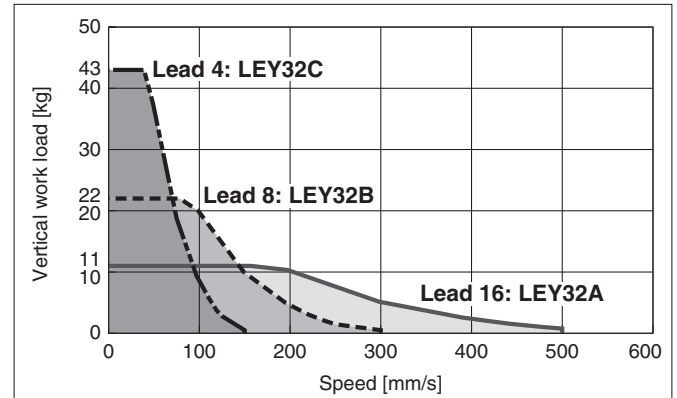

LEY40 

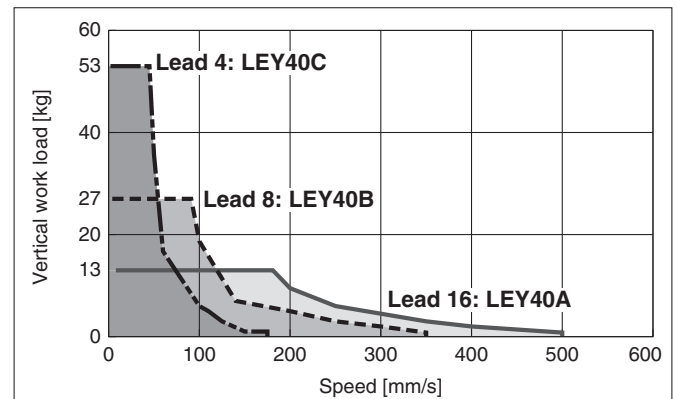

Speed-Work Load Graph (Guide)
For Step Motor (Servo/24 VDC) LECPA, JXC73/83/92/93

Horizontal

LEY16 for acceleration/deceleration: 2000 mm/s²

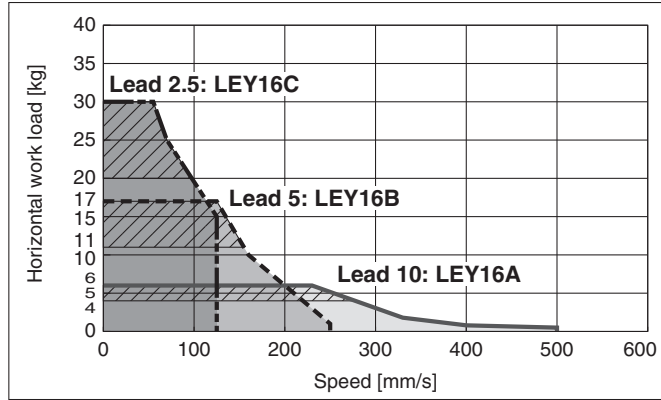

LEY25 for acceleration/deceleration: 2000 mm/s²

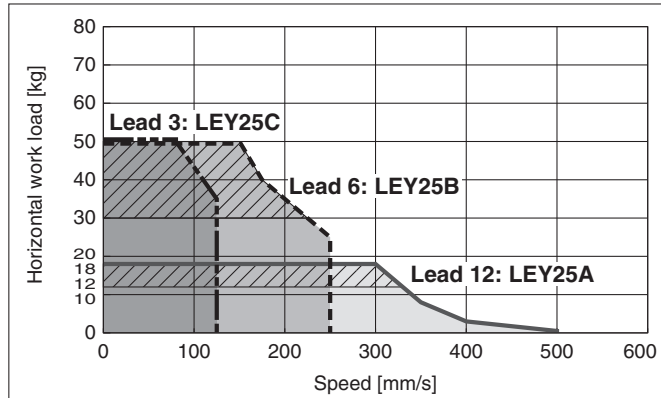

LEY32 for acceleration/deceleration: 2000 mm/s²

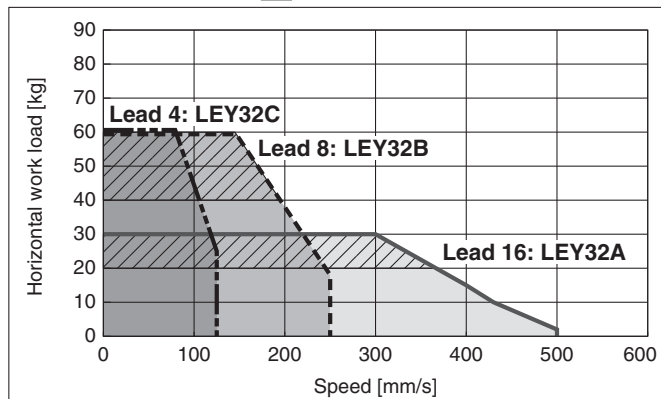

LEY40

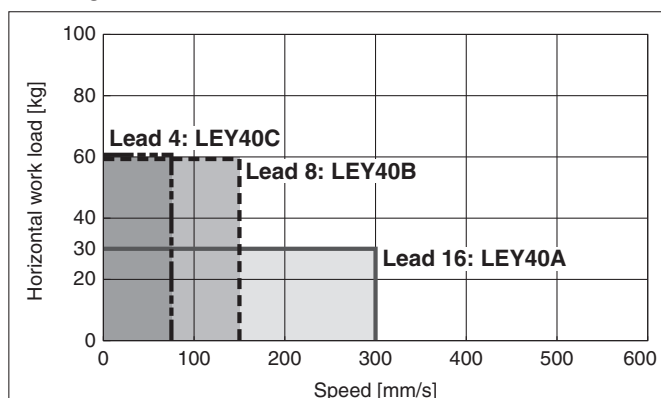

Vertical

LEY16

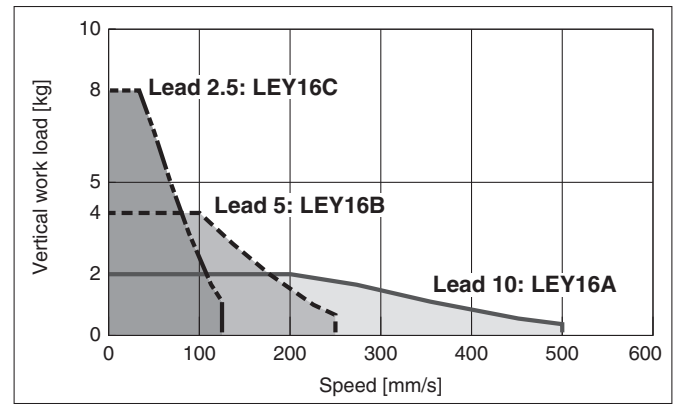

LEY25

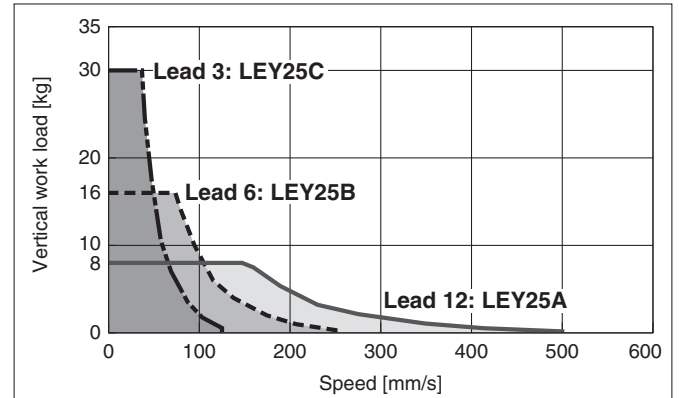

LEY32

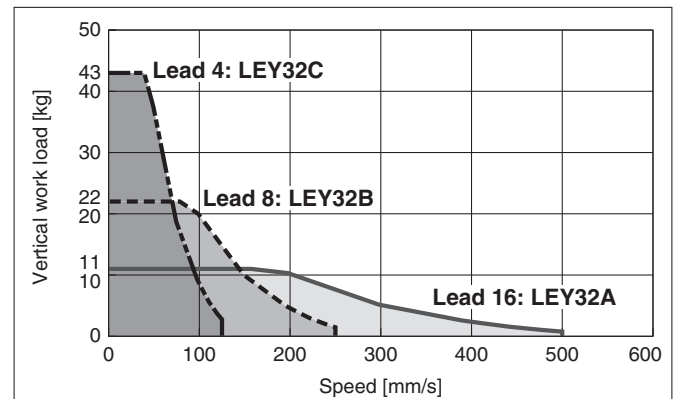

LEY40

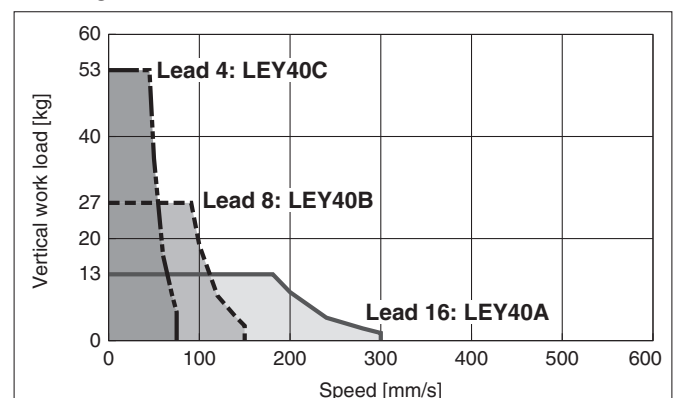

Model Selection

LEY

LEYG

LECA6

LECP6

LEC-G

LECP1

LECPA

JXC

JXC73/83/92/93

JXC73/83/92/93

LEY

LEYG

LECS

LECS-T

LECY

Specific Product Precautions

Series LEY

Step Motor (Servo/24 VDC) Servo Motor (24 VDC)

Speed-Work Load Graph (Guide) For Servo Motor (24 VDC) LECA6

Horizontal

LEY16A□

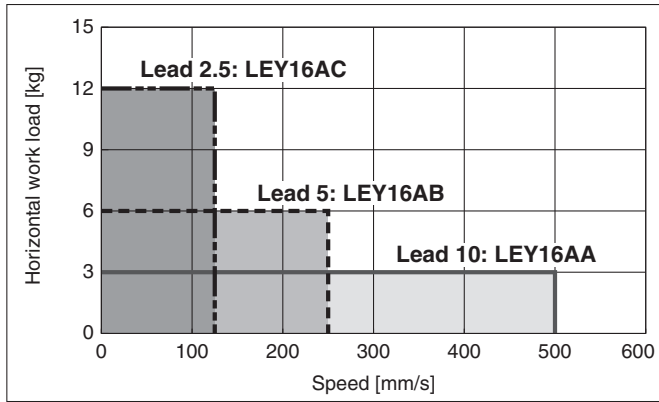

LEY25A□

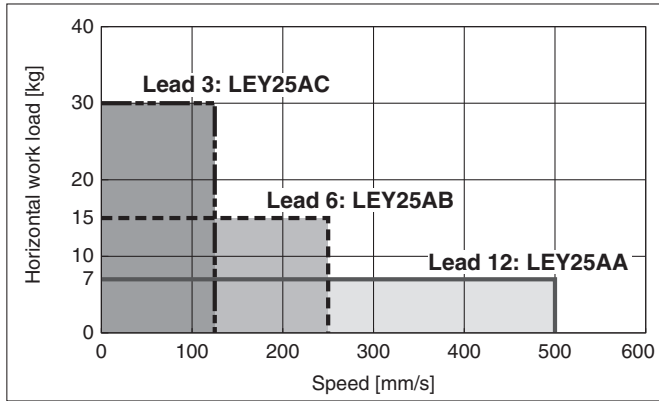

Vertical

LEY16A□

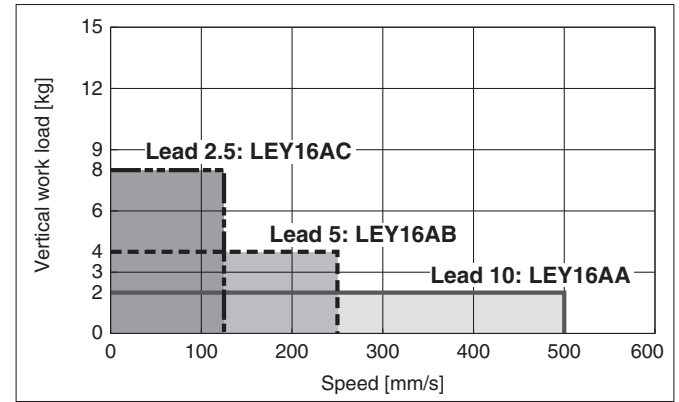

LEY25A□

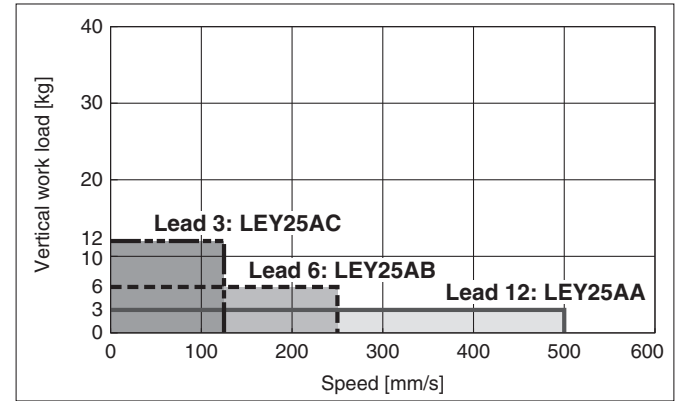

Graph of Allowable Lateral Load on the Rod End (Guide)

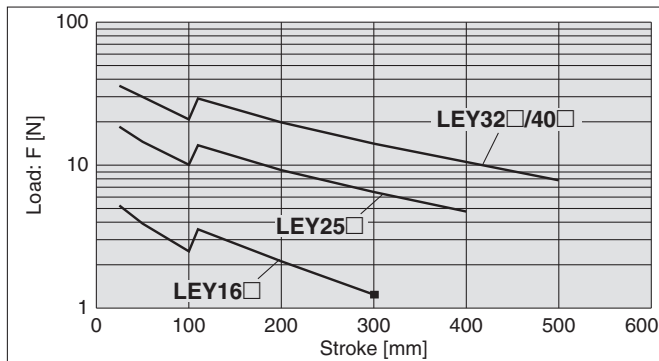

[Stroke] = [Product stroke] + [Distance from the rod end to the center of gravity of the workpiece]

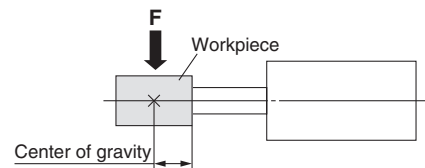

Rod Displacement: δ

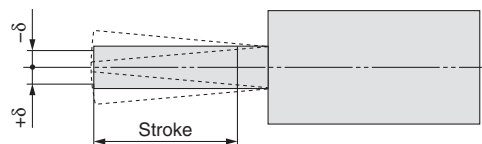

Size	Stroke [mm]										
	30	50	100	150	200	250	300	350	400	450	500
16	±0.4	±0.5	±0.9	±0.8	±1.1	±1.3	±1.5	—	—	—	—
25	±0.3	±0.4	±0.7	±0.7	±0.9	±1.1	±1.3	±1.5	±0.5	—	—
32,40	±0.3	±0.4	±0.7	±0.6	±0.8	±1.0	±1.1	±1.3	±1.5	±1.7	±1.8

Force Conversion Graph (Guide)

Step Motor (Servo/24 VDC)

LEY16

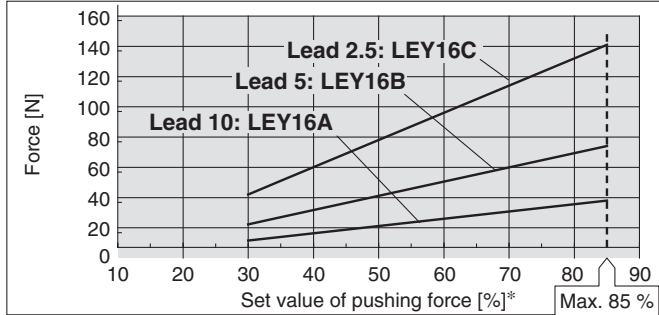

Ambient temperature	Set value of pushing force [%]	Duty ratio [%]	Continuous pushing time (minute)
25 °C or less	85 or less	100	—
	40 or less	100	—
40 °C	50	70	12
	70	20	1.3
	85	15	0.8

LEY25

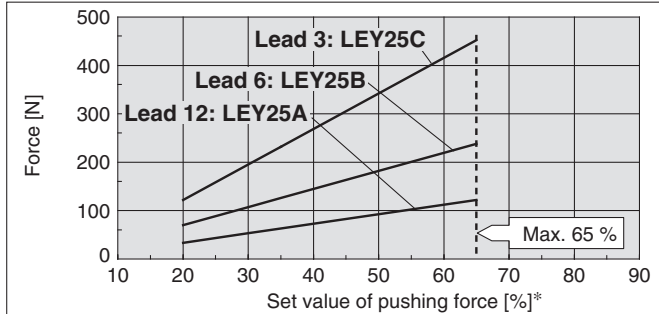

Ambient temperature	Set value of pushing force [%]	Duty ratio [%]	Continuous pushing time (minute)
40 °C or less	65 or less	100	—

LEY32

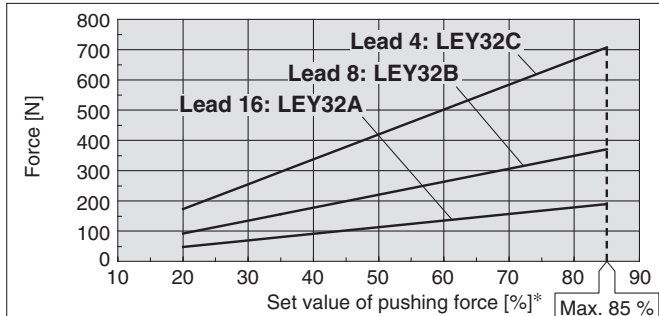

Ambient temperature	Set value of pushing force [%]	Duty ratio [%]	Continuous pushing time (minute)
25 °C or less	85 or less	100	—
	65 or less	100	—
40 °C	85	50	15

LEY40

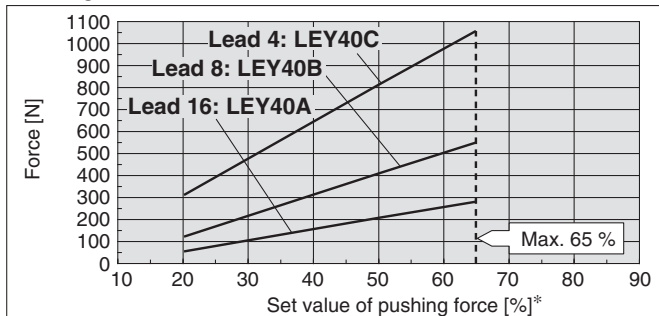

Ambient temperature	Set value of pushing force [%]	Duty ratio [%]	Continuous pushing time (minute)
40 °C or less	65 or less	100	—

* Set values for the controller.

Servo Motor (24 VDC)

LEY16

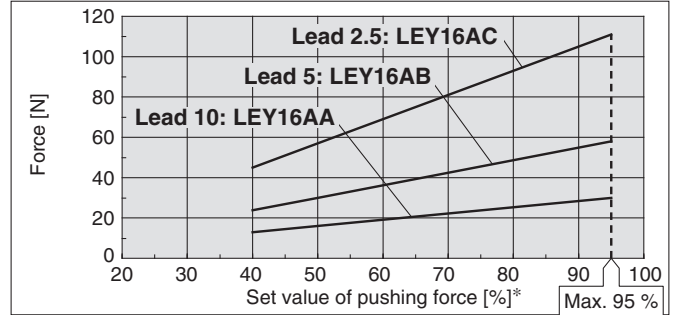

Ambient temperature	Set value of pushing force [%]	Duty ratio [%]	Continuous pushing time (minute)
40 °C or less	95 or less	100	—

LEY25

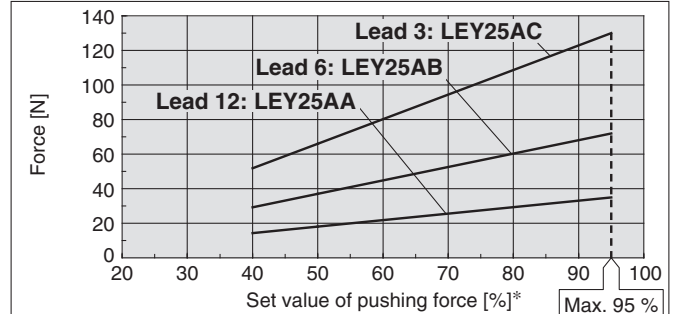

Ambient temperature	Set value of pushing force [%]	Duty ratio [%]	Continuous pushing time (minute)
40 °C or less	95 or less	100	—

<Pushing Force and Trigger Level Range> Without Load

Model	Pushing speed [mm/s]	Pushing force (Setting input value)	Model	Pushing speed [mm/s]	Pushing force (Setting input value)
LEY16□	1 to 4	30 % to 85 %	LEY16□A	1 to 4	40 % to 95 %
	5 to 20	35 % to 85 %		5 to 20	60 % to 95 %
	21 to 50	60 % to 85 %		21 to 50	80 % to 95 %
LEY25□	1 to 4	20 % to 65 %	LEY25□A	1 to 4	40 % to 95 %
	5 to 20	35 % to 65 %		5 to 20	60 % to 95 %
	21 to 35	50 % to 65 %		21 to 35	80 % to 95 %
LEY32□	1 to 4	20 % to 85 %	LEY40□	1 to 4	20 % to 65 %
	5 to 20	35 % to 85 %		5 to 20	35 % to 65 %
	21 to 30	60 % to 85 %		21 to 30	50 % to 65 %

<Set values for vertical upward transfer pushing operation>

Note) For vertical loads (upward), set the pushing force to the maximum value shown below, and operate at the work load or less.

Model	LEY16□	LEY25□	LEY32□	LEY40□	LEY16□A	LEY25□A												
Lead	A	B	C	A	B	C												
Work load [kg]	1	1.5	3	2.5	5	10	4.5	9	18	7	14	28	1	1.5	3	1.2	2.5	5
Pushing force	85 %			65 %			85 %			65 %			95 %			95 %		

Non-rotating Accuracy of Rod

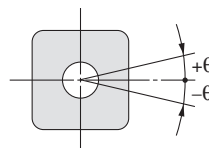

Size	Non-rotating accuracy θ
16	±1.1°
25	±0.8°
32	±0.7°
40	

* Avoid using the electric actuator in such a way that rotational torque would be applied to the piston rod.

This may cause deformation of the non-rotating guide, abnormal responses of the auto switch, play in the internal guide or an increase in the sliding resistance.

Model Selection

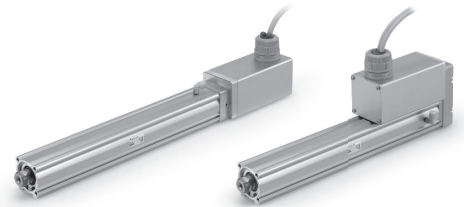

Speed-Work Load Graph (Guide) for Step Motor (Servo/24 VDC) LECP6, LECP1, JXCE1/91/P1/D1/L1

Horizontal

LEY25 for acceleration/deceleration: 2000 mm/s²

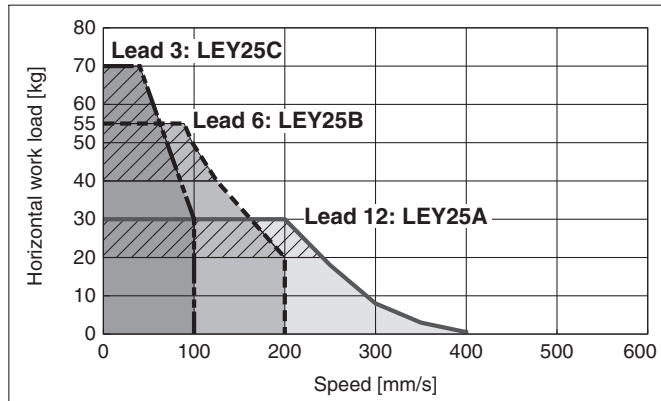

LEY32 for acceleration/deceleration: 2000 mm/s²

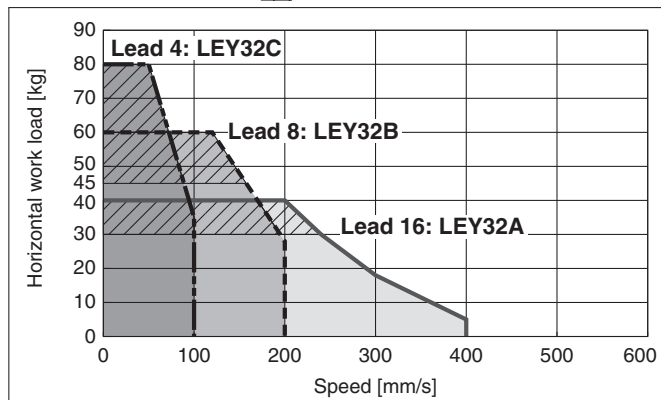

Vertical

LEY25

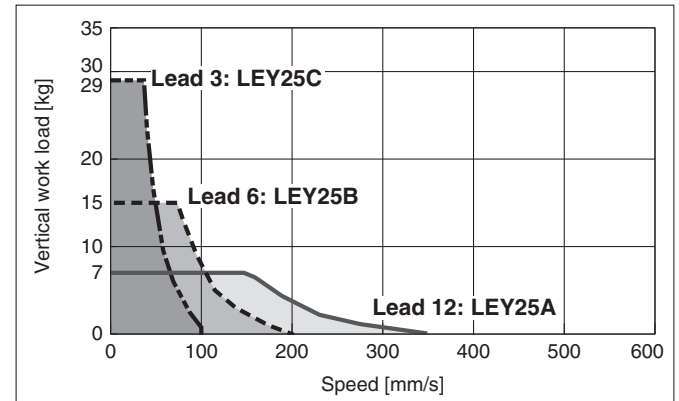

LEY32

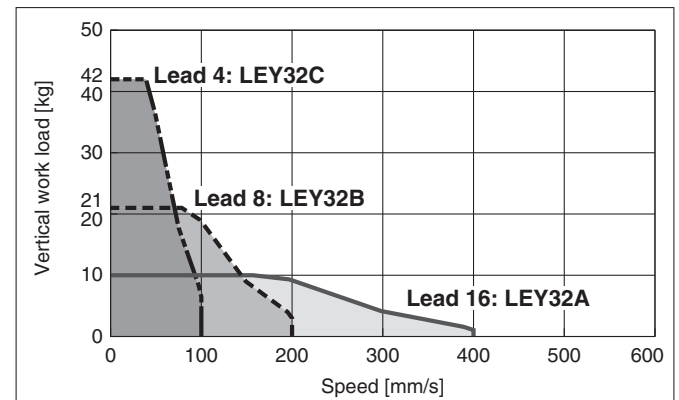

Graph of Allowable Lateral Load on the Rod End (Guide)

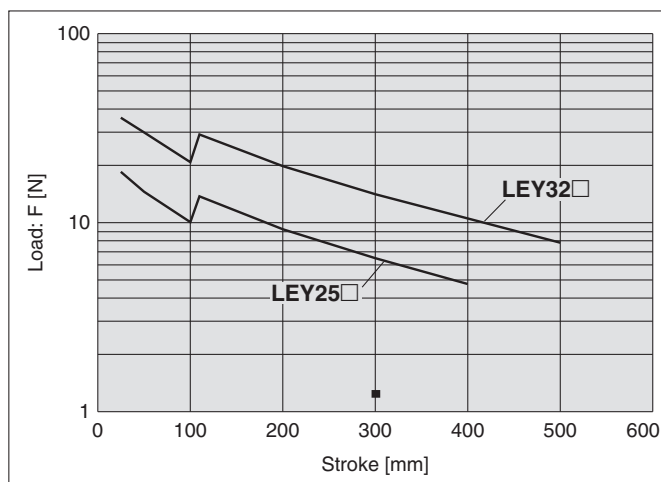

$$[\text{Stroke}] = [\text{Product stroke}] + [\text{Distance from the rod end to the center of gravity of the workpiece}]$$

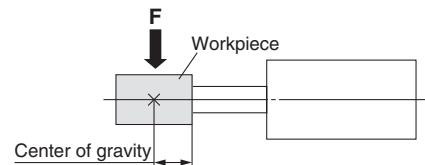

Rod Displacement: δ

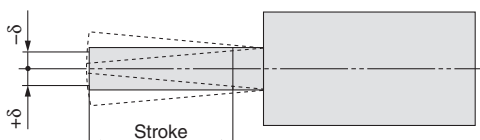

Size	Stroke [mm]										
	30	50	100	150	200	250	300	350	400	450	500
16	±0.4	±0.5	±0.9	±0.8	±1.1	±1.3	±1.5	—	—	—	—
25	±0.3	±0.4	±0.7	±0.7	±0.9	±1.1	±1.3	±1.5	±0.5	—	—
32,40	±0.3	±0.4	±0.7	±0.6	±0.8	±1.0	±1.1	±1.3	±1.5	±1.7	±1.8

Speed-Work Load Graph (Guide)
For Step Motor (Servo/24 VDC) LECPA, JXC73/83/92/93

Horizontal

LEY25  for acceleration/deceleration: 2000 mm/s²

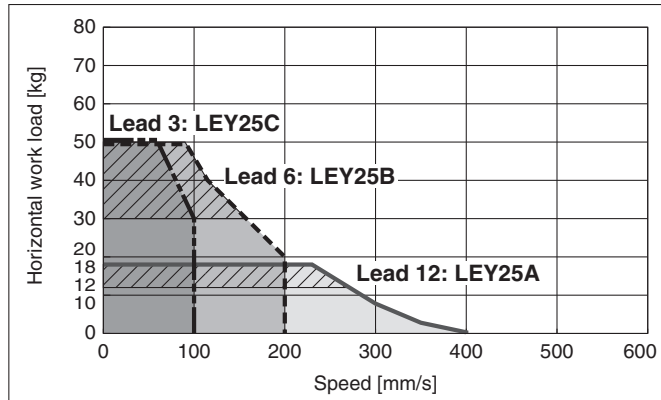

Vertical

LEY25

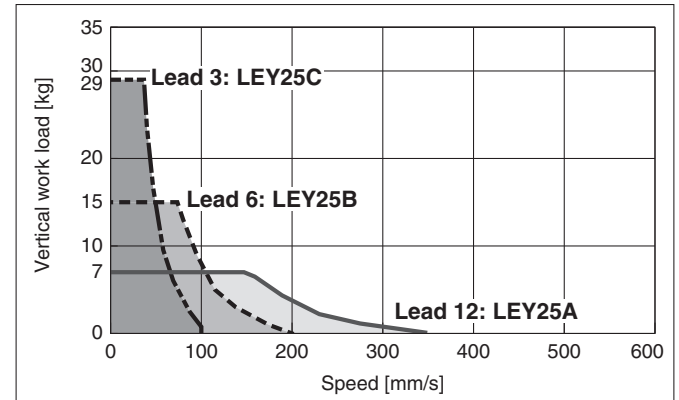

LEY32

 for acceleration/deceleration: 2000 mm/s²

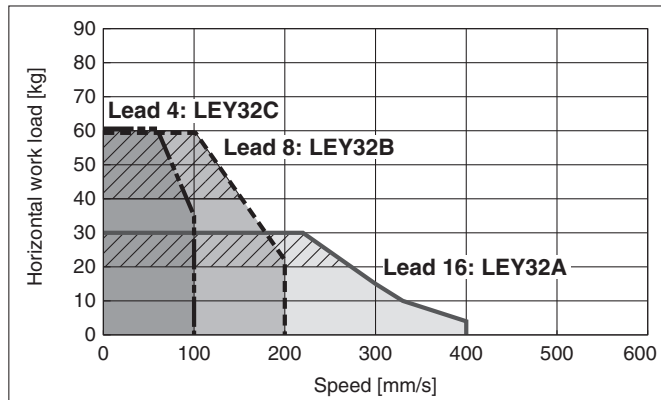

LEY32

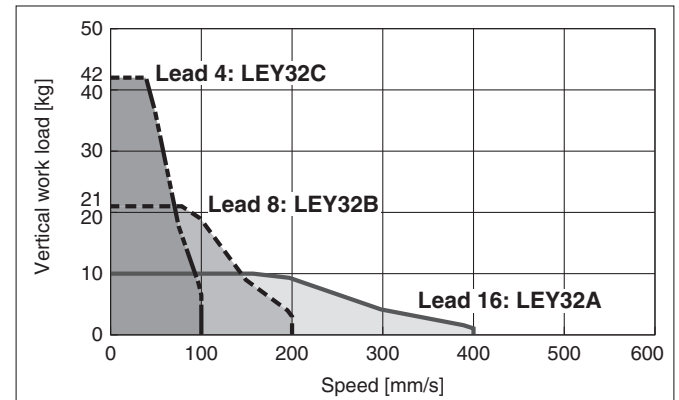

For Servo Motor (24 VDC) LECA6

Horizontal

LEY25A

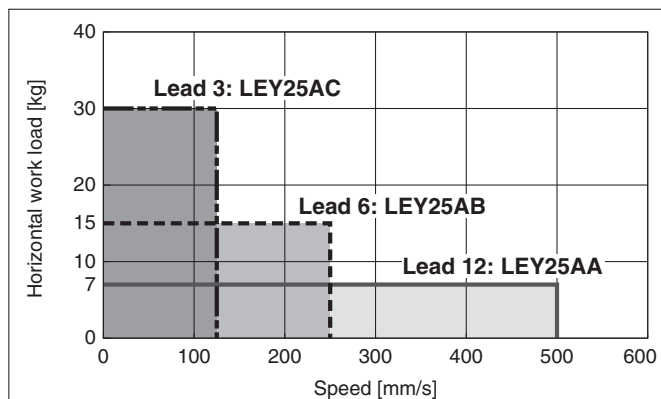

Vertical

LEY25

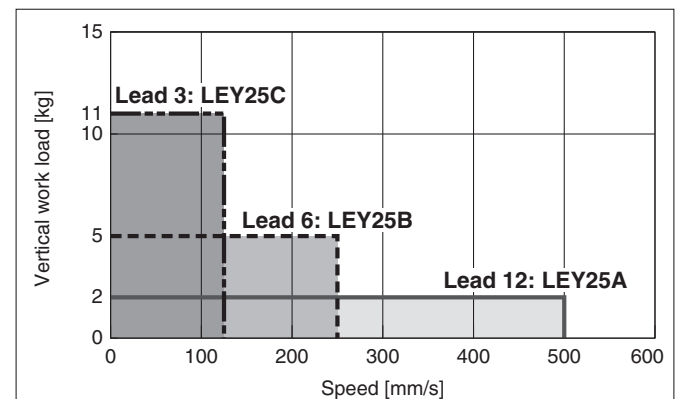

Servo Motor (24 VDC)/Step Motor (Servo/24 VDC)

LEY
LEYG

LECA6
LECP6

LEC-G

LECP1

LECPA

JXC 1
JXC73/83/92/93

AC Servo Motor

LEY
LEYG

LECS

LECS-T

LECY

Specific Product Precautions

Series LEY-X5

Step Motor (Servo/24 VDC)

Servo Motor (24 VDC)

Dust/Drip proof (IP65 equivalent)

Force Conversion Graph

Step Motor (Servo/24 VDC)

LEY25

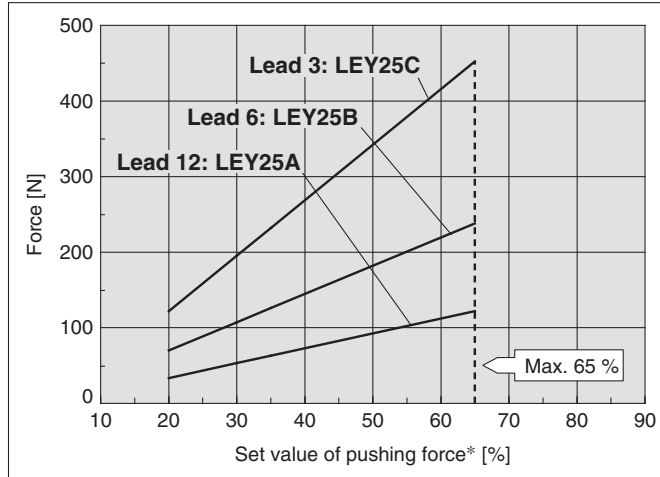

Ambient temperature	Set value of pushing force* [%]	Duty ratio [%]	Continuous pushing time [minute]
40 °C or less	65 or less	100	—

LEY32

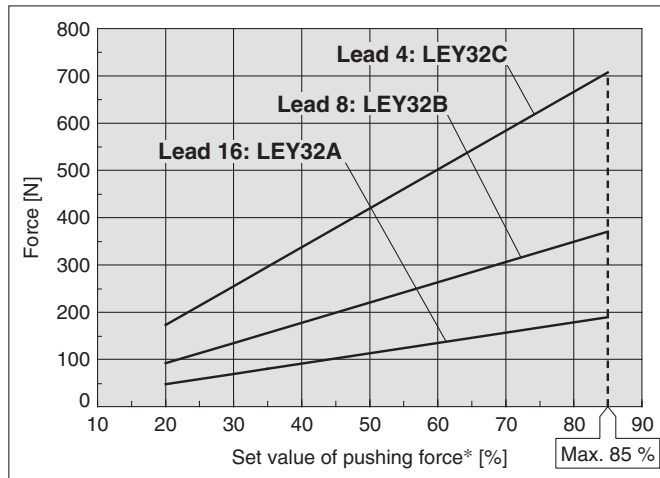

Ambient temperature	Set value of pushing force* [%]	Duty ratio [%]	Continuous pushing time [minute]
25 °C or less	85 or less	100	—
40 °C	65 or less	100	—
	85	50	15

Servo Motor (24 VDC)

LEY25

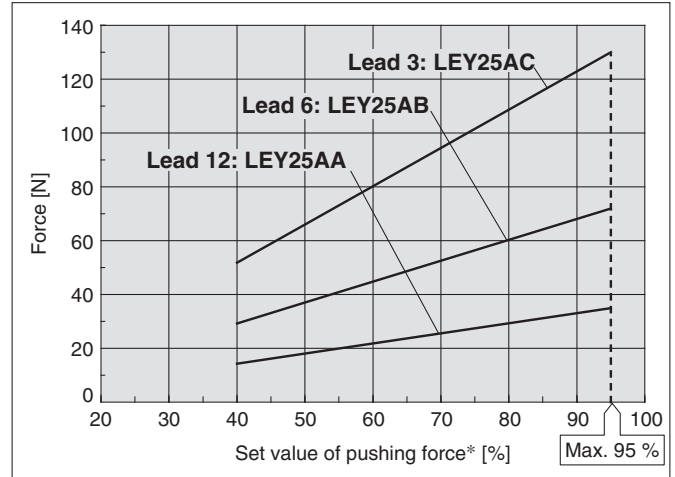

Ambient temperature	Set value of pushing force* [%]	Duty ratio [%]	Continuous pushing time [minute]
40 °C or less	95 or less	100	—

<Pushing Force and Trigger Level Range> Without Load

Model	Pushing speed [mm/s]	Pushing force (Setting input value)	Model	Pushing speed [mm/s]	Pushing force (Setting input value)
LEY25□	1 to 4	20 % to 65 %	LEY25□A	1 to 4	40 % to 95 %
	5 to 20	35 % to 65 %		5 to 20	60 % to 95 %
	21 to 35	50 % to 65 %		21 to 35	80 % to 95 %
LEY32□	1 to 4	20 % to 85 %			
	5 to 20	35 % to 85 %			
	21 to 30	60 % to 85 %			

<Set values for vertical upward transfer pushing operation>

Note) For vertical loads (upward), set the pushing force to the maximum value shown below, and operate at the work load or less.

Model	LEY25□			LEY32□			LEY25□A		
	A	B	C	A	B	C	A	B	C
Work load [kg]	2.5	5	10	4.5	9	18	1.2	2.5	5
Pushing force	65 %			85 %			95 %		

* Set values for the controller.

Specific Product Precautions	LECY <input type="checkbox"/>	LECSS-T	LECS <input type="checkbox"/>	AC Servo Motor		JXC73/63/52/33	JXC <input type="checkbox"/> 1	LECPA	LECP1	LEC-G	LECA6 LECP6	Servo Motor (24 VDC)/Step Motor (Servo/24 VDC)		LEYG	LEY	Model Selection
------------------------------	-------------------------------	---------	-------------------------------	----------------	--	----------------	--------------------------------	-------	-------	-------	----------------	--	--	------	-----	-----------------

Electric Actuator/Rod Type

Step Motor (Servo/24 VDC)

Servo Motor (24 VDC)

Series LEY

LEY16, 25, 32, 40



EtherNet/IP IO-Link Compatible ▶ Page 99
DeviceNet EtherCAT

Multi-Axis Step Motor Controller Compatible ▶ Page 108

How to Order

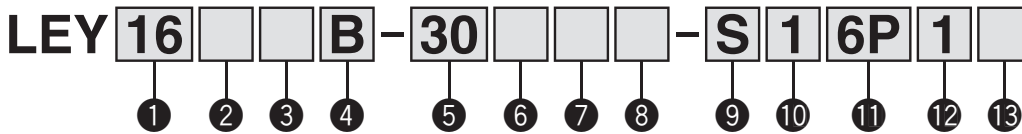

1 Size

16
25
32
40

2 Motor mounting position

—	Top mounting
R	Right side parallel
L	Left side parallel
D	In-line

3 Motor type

Symbol	Type	Size			Compatible controllers/driver
		LEY16	LEY25	LEY32/40	
—	Step motor (Servo/24 VDC)	●	●	●	LECP6 LECP1 LECPA
A	Servo motor (24 VDC)	●	●	—	LECA6

4 Lead [mm]

Symbol	LEY16	LEY25	LEY32/40
A	10	12	16
B	5	6	8
C	2.5	3	4

5 Stroke [mm]

30	30
to	to
500	500

* Refer to the applicable stroke table.

6 Motor option

—	Without option
C	With motor cover
B	With lock
W	With lock and motor cover

Note) When "With lock" or "With lock and motor cover" is selected for the top mounting and right/left side parallel types, the motor body will stick out of the end of the body for size 16/40 with strokes 30 or less. Check for interference with workpieces before selecting a model.

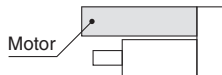

7 Rod end thread

—	Rod end female thread
M	Rod end male thread (1 rod end nut is included.)

⚠ Caution

[CE-compliant products]

- EMC compliance was tested by combining the electric actuator LEY series and the controller LEC series. The EMC depends on the configuration of the customer's control panel and the relationship with other electrical equipment and wiring. Therefore conformity to the EMC directive cannot be certified for SMC components incorporated into the customer's equipment under actual operating conditions. As a result it is necessary for the customer to verify conformity to the EMC directive for the machinery and equipment as a whole.

- For the servo motor (24 VDC) specification, EMC compliance was tested by installing a noise filter set (LEC-NFA). Refer to page 73 for the noise filter set. Refer to the LECA Operation Manual for installation.

[UL-compliant products]

When conformity to UL is required, the electric actuator and controller/driver should be used with a UL1310 Class 2 power supply.

For auto switches, refer to pages 27 and 28.

* Applicable stroke table

Model	Stroke [mm]											Manufacturable stroke range [mm]
	30	50	100	150	200	250	300	350	400	450	500	
LEY16	●	●	●	●	●	●	●	—	—	—	—	10 to 300
LEY25	●	●	●	●	●	●	●	●	●	—	—	15 to 400
LEY32/40	●	●	●	●	●	●	●	●	●	●	●	20 to 500

* Consult with SMC for non-standard strokes as they are produced as special orders.

The actuator and controller/driver are sold as a package.

Confirm that the combination of the controller/driver and the actuator is correct.

<Check the following before use.>

- Check the actuator label for model number. This matches the controller/driver.
- Check Parallel I/O configuration matches (NPN or PNP)

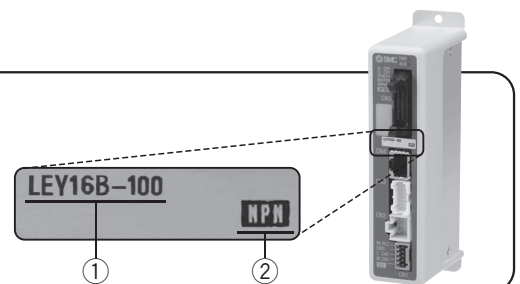

* Refer to the operation manual for using the products. Please download it via our website, <http://www.smcworld.com>

Electric Actuator/Rod Type **Series LEY**

Step Motor (Servo/24 VDC) Servo Motor (24 VDC)

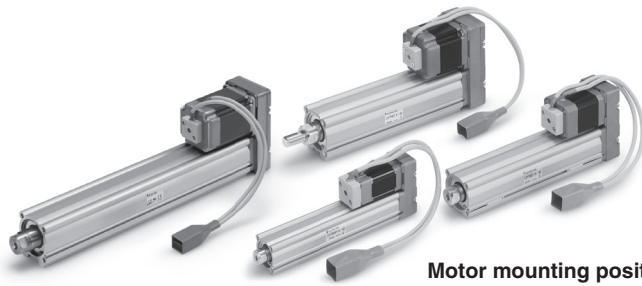

Motor mounting position: Top/Parallel

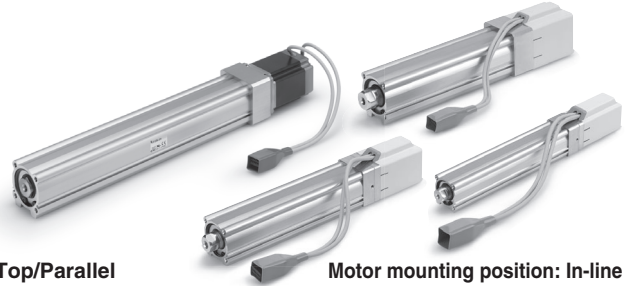

Motor mounting position: In-line

8 Mounting*1

Symbol	Type	Motor mounting position	
		Top/Parallel	In-line
—	Ends tapped*2 Body bottom tapped	●	●
L	Foot	●	—
F	Rod flange*2	●*4	●
G	Head flange*2	●*5	—
D	Double clevis*3	●	—

- *1 Mounting bracket is shipped together, (but not assembled).
- *2 For horizontal cantilever mounting with the rod flange, head flange and ends tapped, use the actuator within the following stroke range.
 - LEY25: 200 or less
 - LEY32/40: 100 or less
- *3 For mounting with the double clevis, use the actuator within the following stroke range.
 - LEY16: 100 or less
 - LEY25: 200 or less
 - LEY32/40: 200 or less
- *4 Rod flange is not available for the LEY16/40 with stroke 30 mm and motor option "With lock", "With lock/motor cover".
- *5 Head flange is not available for the LEY32/40.

13 Controller/Driver mounting

—	Screw mounting
D	DIN rail mounting*1

*1 DIN rail is not included. Order it separately.

9 Actuator cable type*1

—	Without cable
S	Standard cable*2
R	Robotic cable (Flexible cable)*3

- *1 The standard cable should be used on fixed parts. For using on moving parts, select the robotic cable.
- *2 Only available for the motor type "Step motor."
- *3 Fix the motor cable protruding from the actuator to keep it unmovable. For details about fixing method, refer to Wiring/Cables in the Electric Actuators Precautions.

11 Controller/Driver type*1

—	Without controller/driver	
6N	LECP6/LECA6 (Step data input type)	NPN
6P		PNP
1N	LECP1 *2 (Programless type)	NPN
1P		PNP
AN	LECPA *2, *3 (Pulse input type)	NPN
AP		PNP

- *1 For details about controller/drivers and compatible motors, refer to the compatible controller/drivers below.
- *2 Only available for the motor type "Step motor."
- *3 When pulse signals are open collector, order the current limiting resistor separately.

10 Actuator cable length [m]

—	Without cable
1	1.5
3	3
5	5
8	8*
A	10*
B	15*
C	20*





* Produced upon receipt of order (Robotic cable only). Refer to the specifications Note 5) on page 13.

12 I/O cable length [m]*1, Communication plug

—	Without cable
1	1.5
3	3*2
5	5*2

- *1 When "Without controllers/driver" is selected for controller/driver types, I/O cable cannot be selected. Refer to page 73 (For LECP6/LECA6), page 86 (For LECP1) or page 93 (For LECPA) if I/O cable is required.
- *2 When "Pulse input type" is selected for controller/driver types, pulse input usable only with differential. Only 1.5 m cables usable with open collector.

Compatible Controllers/Driver

Type	Step data input type 	Step data input type 	Programless type 	Pulse input type 
Series	LECP6	LECA6	LECP1	LECPA
Features	Value (Step data) input Standard controller		Capable of setting up operation (step data) without using a PC or teaching box	Operation by pulse signals
Compatible motor	Step motor (Servo/24 VDC)	Servo motor (24 VDC)	Step motor (Servo/24 VDC)	
Maximum number of step data	64 points		14 points	—
Power supply voltage	24 VDC			
Reference page	Page 65	Page 65	Page 80	Page 87

Specifications

Step Motor (Servo/24 VDC)

Model		LEY16			LEY25			LEY32			LEY40					
Stroke [mm] ^{Note 1)}		30, 50, 100, 150 200, 250, 300			30, 50, 100, 150, 200 250, 300, 350, 400			30, 50, 100, 150, 200, 250 300, 350, 400, 450, 500			30, 50, 100, 150, 200, 250 300, 350, 400, 450, 500					
Work load [kg] ^{Note 2)}	Horizontal (LECP6, LECP1, JXC□1)	(3000 [mm/s ²])	6	17	30	20	40	60	30	45	60	50	60	80		
		(2000 [mm/s ²])	10	23	35	30	55	70	40	60	80	60	70	90		
	Horizontal (LECPA, JXC□3)	(3000 [mm/s ²])	4	11	20	12	30	30	20	40	40	30	60	60		
		(2000 [mm/s ²])	6	17	30	18	50	50	30	60	60	—	—	—		
	Vertical	(3000 [mm/s ²])	2	4	8	8	16	30	11	22	43	13	27	53		
Pushing force [N] ^{Note 3) 4) 5)}		14 to 38			27 to 74	51 to 141	63 to 122	126 to 238	232 to 452	80 to 189	156 to 370	296 to 707	132 to 283	266 to 553	562 to 1058	
Speed [mm/s] ^{Note 5)}	LECP6/LECP1		15 to 500			8 to 250	4 to 125	18 to 500	9 to 250	5 to 125	24 to 500	12 to 300	6 to 150	24 to 500	12 to 350	6 to 175
	LECPA											12 to 250	6 to 125	24 to 300	12 to 150	6 to 75
Max. acceleration/deceleration [mm/s²]		3000														
Pushing speed [mm/s] ^{Note 6)}		50 or less			35 or less			30 or less			30 or less					
Positioning repeatability [mm]		±0.02														
Lost motion [mm] ^{Note 7)}		0.1 or less														
Screw lead [mm]		10	5	2.5	12	6	3	16	8	4	16	8	4			
Impact/Vibration resistance [m/s²] ^{Note 8)}		50/20														
Actuation type		Ball screw + Belt (LEY□)/Ball screw (LEY□D)														
Guide type		Sliding bushing (Piston rod)														
Operating temperature range [°C]		5 to 40														
Operating humidity range [%RH]		90 or less (No condensation)														
Motor size		□28			□42			□56.4			□56.4					
Motor type		Step motor (Servo/24 VDC)														
Encoder		Incremental A/B phase (800 pulse/rotation)														
Rated voltage [V]		24 VDC ±10 %														
Power consumption [W] ^{Note 9)}		23			40			50			50					
Standby power consumption when operating [W] ^{Note 10)}		16			15			48			48					
Max. instantaneous power consumption [W] ^{Note 11)}		43			48			104			106					
Type ^{Note 12)}		Non-magnetizing lock														
Holding force [N]		20	39	78	78	157	294	108	216	421	127	265	519			
Power consumption [W] ^{Note 13)}		2.9			5			5			5					
Rated voltage [V]		24 VDC ±10 %														

Note 1) Please consult with SMC for non-standard strokes as they are produced as special orders.

Note 2) Horizontal: The maximum value of the work load. An external guide is necessary to support the load (Friction coefficient of guide: 0.1 or less). The actual work load and transfer speed change according to the condition of the external guide. Also, speed changes according to the work load. Check "Model Selection" on pages 5 and 6.

Vertical: Speed changes according to the work load. Check "Model Selection" on pages 5 and 6.

The values shown in () are the acceleration/deceleration.

Set these values to be 3000 [mm/s²] or less.

Note 3) Pushing force accuracy is ±20 % (F.S.).

Note 4) The pushing force values for LEY16□ is 35 % to 85 %, for LEY25□ is 35 % to 65 %, for LEY32□ is 35 % to 85 % and for LEY40□ is 35 % to 65 %. The pushing force values change according to the duty ratio and pushing speed. Check "Model Selection" on page 8.

Note 5) The speed and force may change depending on the cable length, load and mounting conditions. Furthermore, if the cable length exceeds 5 m, then it will decrease by up to 10 % for each 5 m. (At 15 m: Reduced by up to 20 %)

Note 6) The allowable speed for pushing operation. When push conveying a workpiece, operate at the vertical work load or less.

Note 7) A reference value for correcting an error in reciprocal operation.

Note 8) Impact resistance: No malfunction occurred when the actuator was tested with a drop tester in both an axial direction and a perpendicular direction to the lead screw. (Test was performed with the actuator in the initial state.)

Vibration resistance: No malfunction occurred in a test ranging between 45 to 2000 Hz. Test was performed in both an axial direction and a perpendicular direction to the lead screw. (Test was performed with the actuator in the initial state.)

Note 9) The power consumption (including the controller) is for when the actuator is operating.

Note 10) The standby power consumption when operating (including the controller) is for when the actuator is stopped in the set position during the operation. Except during the pushing operation.

Note 11) The maximum instantaneous power consumption (including the controller) is for when the actuator is operating. This value can be used for the selection of the power supply.

Note 12) With lock only

Note 13) For an actuator with lock, add the power consumption for the lock.

Specifications

Servo Motor (24 VDC)

Model		LEY16A				LEY25A				
Actuator specifications	Stroke [mm] ^{Note 1)}	30, 50, 100, 150 200, 250, 300				30, 50, 100, 150, 200 250, 300, 350, 400				
	Work load [kg] ^{Note 2)}	Horizontal (3000 [mm/s ²])	3	6	12	7	15	30		
		Vertical (3000 [mm/s ²])	2	4	8	3	6	12		
	Pushing force [N] ^{Note 3) 4)}	16 to 30	30 to 58	57 to 111	18 to 35	37 to 72	66 to 130			
	Speed [mm/s]	1 to 500	1 to 250	1 to 125	2 to 500	1 to 250	1 to 125			
	Max. acceleration/deceleration [mm/s ²]	3000								
	Pushing speed [mm/s] ^{Note 5)}	50 or less				35 or less				
	Positioning repeatability [mm]	±0.02								
	Lost motion [mm] ^{Note 6)}	0.1 or less								
	Screw lead [mm]	10	5	2.5	12	6	3			
	Impact/Vibration resistance [m/s ²] ^{Note 7)}	50/20								
	Actuation type	Ball screw + Belt (LEY□□)/Ball screw (LEY□D)								
	Guide type	Sliding bushing (Piston rod)								
	Operating temperature range [°C]	5 to 40								
Operating humidity range [%RH]	90 or less (No condensation)									
Electric specifications	Motor size	□28				□42				
	Motor output [W]	30				36				
	Motor type	Servo motor (24 VDC)								
	Encoder	Incremental A/B phase (800 pulse/rotation)/Z phase								
	Rated voltage [V]	24 VDC ±10 %								
	Power consumption [W] ^{Note 8)}	40				86				
	Standby power consumption when operating [W] ^{Note 9)}	4 (Horizontal)/6 (Vertical)				4 (Horizontal)/12 (Vertical)				
Lock unit specifications	Max. instantaneous power consumption [W] ^{Note 10)}	59				96				
	Type ^{Note 11)}	Non-magnetizing lock								
	Holding force [N]	20	39	78	78	157	294			
Power consumption [W] ^{Note 12)}	2.9				5					
Rated voltage [V]	24 VDC ±10 %									

- Note 1) Consult with SMC for non-standard strokes as they are produced as special orders.
- Note 2) Horizontal: The maximum value of the work load. An external guide is necessary to support the load. The actual work load and transfer speed change according to the condition of the external guide.
Vertical: Check "Model Selection" on page 7 for details. The values shown in () are the acceleration/deceleration. Set these values to be 3000 [mm/s²] or less.
- Note 3) Pushing force accuracy is ±20 % (F.S.).
- Note 4) The pushing force values for LEY16A□ is 50 % to 95 % and for LEY25A□ is 50 % to 95 %. The pushing force values change according to the duty ratio and pushing speed. Check "Model Selection" on page 8.
- Note 5) The allowable speed for pushing operation. When push conveying a workpiece, operate at the vertical work load or less.
- Note 6) A reference value for correcting an error in reciprocal operation.
- Note 7) Impact resistance: No malfunction occurred when the actuator was tested with a drop tester in both an axial direction and a perpendicular direction to the lead screw. (Test was performed with the actuator in the initial state.)
Vibration resistance: No malfunction occurred in a test ranging between 45 to 2000 Hz. Test was performed in both an axial direction and a perpendicular direction to the lead screw. (Test was performed with the actuator in the initial state.)
- Note 8) The power consumption (including the controller) is for when the actuator is operating.
- Note 9) The standby power consumption when operating (including the controller) is for when the actuator is stopped in the set position during the operation. Except during the pushing operation.
- Note 10) The maximum instantaneous power consumption (including the controller) is for when the actuator is operating. This value can be used for the selection of the power supply.
- Note 11) With lock only
- Note 12) For an actuator with lock, add the power consumption for the lock.

Weight

Weight: Motor Top/Parallel Type

Series	LEY16								LEY25								LEY32											
	Stroke [mm]	30	50	100	150	200	250	300	30	50	100	150	200	250	300	350	400	30	50	100	150	200	250	300	350	400	450	500
Product weight [kg]	Step motor	0.58	0.62	0.73	0.87	0.98	1.09	1.20	1.18	1.25	1.42	1.68	1.86	2.03	2.21	2.38	2.56	2.09	2.20	2.49	2.77	3.17	3.46	3.74	4.03	4.32	4.60	4.89
	Servo motor	0.58	0.62	0.73	0.87	0.98	1.09	1.20	1.14	1.21	1.38	1.64	1.82	1.99	2.17	2.34	2.52	—	—	—	—	—	—	—	—	—	—	—

Series	LEY40											
	Stroke [mm]	30	50	100	150	200	250	300	350	400	450	500
Product weight [kg]	Step motor	2.39	2.50	2.79	3.07	3.47	3.76	4.04	4.33	4.62	4.90	5.19
	Servo motor	—	—	—	—	—	—	—	—	—	—	—

Weight: In-line Motor Type

Series	LEY16D								LEY25D								LEY32D											
	Stroke [mm]	30	50	100	150	200	250	300	30	50	100	150	200	250	300	350	400	30	50	100	150	200	250	300	350	400	450	500
Product weight [kg]	Step motor	0.58	0.62	0.73	0.87	0.98	1.09	1.20	1.17	1.24	1.41	1.67	1.85	2.02	2.20	2.37	2.55	2.08	2.19	2.48	2.76	3.16	3.45	3.73	4.02	4.31	4.59	4.88
	Servo motor	0.58	0.62	0.73	0.87	0.98	1.09	1.20	1.13	1.20	1.37	1.63	1.81	1.98	2.16	2.33	2.51	—	—	—	—	—	—	—	—	—	—	—

Series	LEY40D											
	Stroke [mm]	30	50	100	150	200	250	300	350	400	450	500
Product weight [kg]	Step motor	2.38	2.49	2.78	3.06	3.46	3.75	4.03	4.32	4.61	4.89	5.18
	Servo motor	—	—	—	—	—	—	—	—	—	—	—

Additional Weight

Size	16	25	32	40	
Lock	0.12	0.26	0.53	0.53	
Motor cover	0.02	0.03	0.04	0.05	
Rod end male thread	Male thread	0.01	0.03	0.03	0.03
	Nut	0.01	0.02	0.02	0.02
Foot (2 sets including mounting bolt)	0.06	0.08	0.14	0.14	
Rod flange (including mounting bolt)	0.13	0.17	0.20	0.20	
Head flange (including mounting bolt)					
Double clevis (including pin, retaining ring and mounting bolt)	0.08	0.16	0.22	0.22	

Model Selection
 LEY
 Servo Motor (24 VDC)/Step Motor (Servo/24 VDC)
 LEY
 LEYG
 LECA6
 LECP6
 LEC-G
 LEC-CP1
 LEC-PA
 JXC□1
 JXC7□□□□□□□□
 AC Servo Motor
 LEY
 LEYG
 LEC□
 LECSS-T
 LECY□
 Specific Product Precautions

Construction

In-line motor type: LEY 16
25 D
32
40

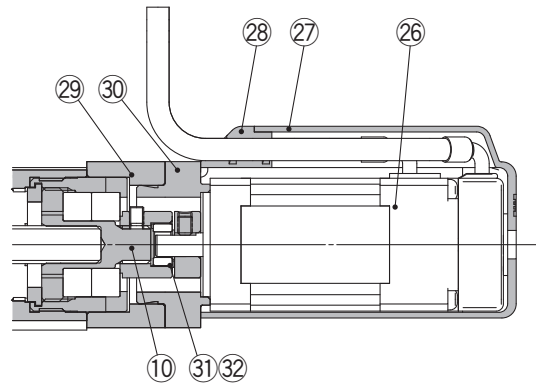

In-line motor type: With lock/motor cover

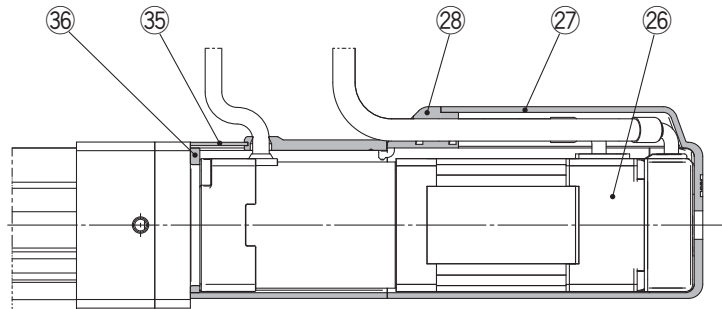

Component Parts

No.	Description	Material	Note
1	Body	Aluminium alloy	Anodised
2	Ball screw (shaft)	Alloy steel	
3	Ball screw nut	Resin/Alloy steel	
4	Piston	Aluminium alloy	
5	Piston rod	Stainless steel	Hard chrome plating
6	Rod cover	Aluminium alloy	
7	Housing	Aluminium alloy	
8	Rotation stopper	POM	
9	Socket	Free cutting carbon steel	Nickel plating
10	Connected shaft	Free cutting carbon steel	Nickel plating
11	Bushing	Lead bronze cast	
12	Bumper	Urethane	
13	Bearing	—	
14	Return box	Aluminium die-cast	Coating
15	Return plate	Aluminium die-cast	Coating
16	Magnet	—	
17	Wear ring holder	Stainless steel	Stroke 101 mm or more
18	Wear ring	POM	Stroke 101 mm or more
19	Screw shaft pulley	Aluminium alloy	
20	Motor pulley	Aluminium alloy	
21	Belt	—	
22	Bearing stopper	Aluminium alloy	
23	Parallel pin	Stainless steel	
24	Seal	NBR	
25	Retaining ring	Steel for spring	Phosphate coated

No.	Description	Material	Note
26	Motor	—	
27	Motor cover	Synthetic resin	Only "With motor cover"
28	Grommet	Synthetic resin	Only "With motor cover"
29	Motor block	Aluminium alloy	Anodised
30	Motor adapter	Aluminium alloy	Anodised/LEY16, 25 only
31	Hub	Aluminium alloy	
32	Spider	NBR	
33	Socket (Male thread)	Free cutting carbon steel	Nickel plating
34	Nut	Alloy steel	
35	Motor cover with lock	Aluminium alloy	Only "With lock/motor cover"
36	Cover support	Aluminium alloy	Only "With lock/motor cover"

Replacement Parts (Top/Parallel only)/Belt

No.	Size	Order no.
21	16	LE-D-2-1
	25	LE-D-2-2
	32, 40	LE-D-2-3

Replacement Parts/Grease Pack

Applied portion	Order no.
Piston rod	GR-S-010 (10 g) GR-S-020 (20 g)

* Apply grease on the piston rod periodically.
Grease should be applied at 1 million cycles or 200 km, whichever comes first.

Model Selection

Servo Motor (24 VDC)/Step Motor (Servo/24 VDC)

LEY

LEYG

LECA6
LECP6

LEC-G

LECP1

LECPA

JXC□1

JXC7/3/3/3/2/3/3

LEY

AC Servo Motor

LEYG

LECS□

LECS-T

LECY□

Specific Product Precautions

Series LEY

Step Motor (Servo/24 VDC) Servo Motor (24 VDC)

Dimensions: Motor Top/Parallel

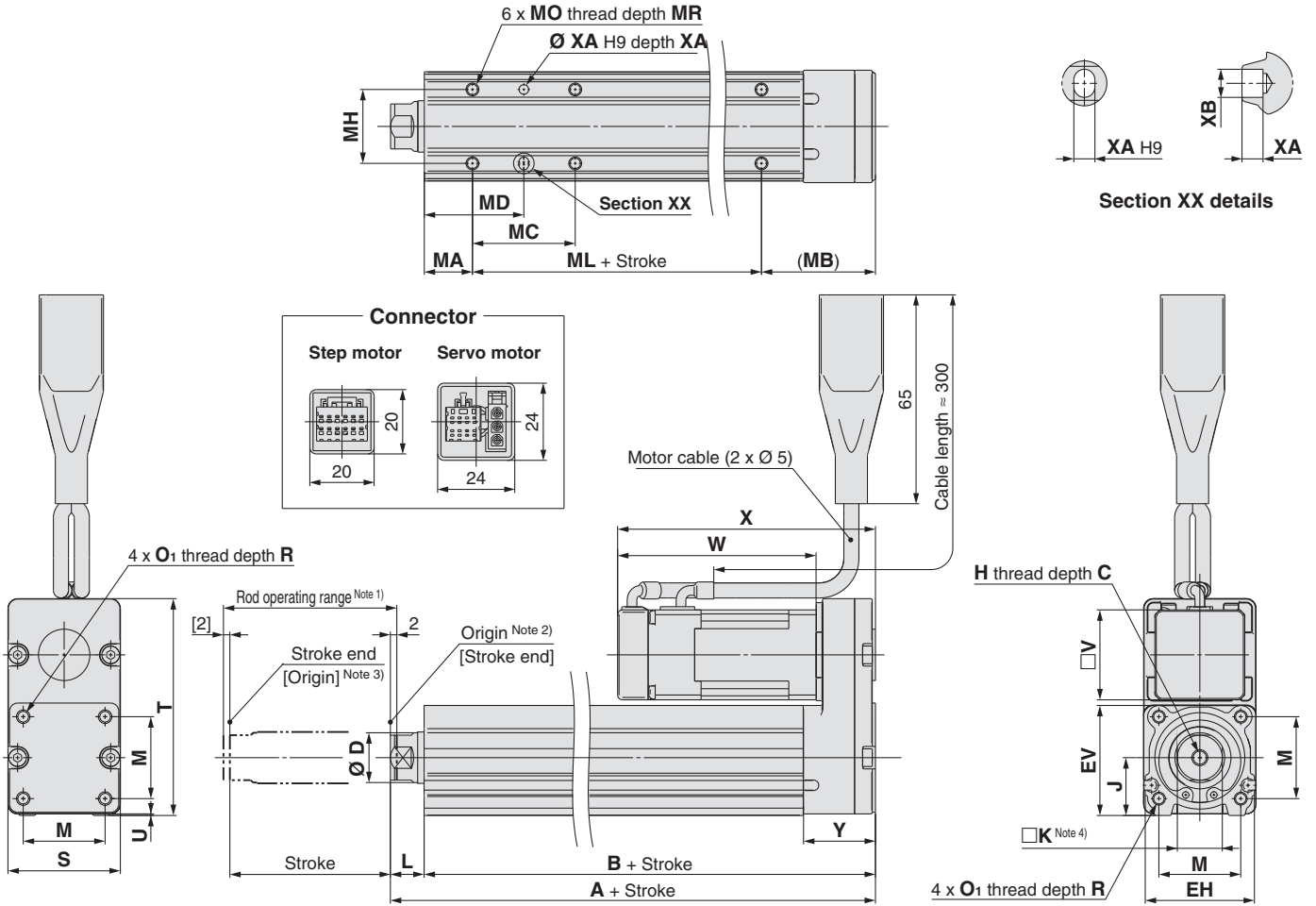

- Note 1) Range within which the rod can move when it returns to origin. Make sure a workpiece mounted on the rod does not interfere with the workpieces and facilities around the rod.
 Note 2) Position after return to origin.
 Note 3) [] for when the direction of return to origin has changed.
 Note 4) The direction of rod end width across flats (□K) differs depending on the products.

Size	Stroke range [mm]	A	B	C	D	EH	EV	H	J	K	L	M	O ₁	R	S	T	U	V	Step motor		Servo motor		Y
																			W	X	W	X	
16	10 to 100	101	90.5	10	16	34	34.3	M5 x 0.8	18	14	10.5	25.5	M4 x 0.7	7	35	67.5	0.5	28	61.8	80.3	62.5	81	22.5
	101 to 300	121	110.5																				
25	15 to 100	130.5	116	13	20	44	45.5	M8 x 1.25	24	17	14.5	34	M5 x 0.8	8	46	92	1	42	63.4	85.4	59.6	81.6	26.5
	101 to 400	155.5	141																				
32	20 to 100	148.5	130	13	25	51	56.5	M8 x 1.25	31	22	18.5	40	M6 x 1.0	10	60	118	1	56.4	68.4	95.4	—	—	34
	101 to 500	178.5	160																				
40	20 to 100	148.5	130	13	25	51	56.5	M8 x 1.25	31	22	18.5	40	M6 x 1.0	10	60	118	1	56.4	90.4	117.4	—	—	34
	101 to 500	178.5	160																				

Body Bottom Tapped

Size	Stroke range [mm]	MA	MB	MC	MD	MH	ML	MO	MR	XA	XB
16	10 to 39	15	35.5	17	23.5	23	40	M4 x 0.7	5.5	3	4
	40 to 100			32	31						
	101 to 300			62	46						
25	15 to 39	20	46	24	32	29	50	M5 x 0.8	6.5	4	5
	40 to 100			42	41						
	101 to 124			59	49.5						
	125 to 200			76	58						
	201 to 400			76	58						
32	20 to 39	25	55	22	36	30	50	M6 x 1	8.5	5	6
	40 to 100			36	43						
	101 to 124			53	51.5						
	125 to 200			53	51.5						
	201 to 500			70	60						

Dimensions: Motor Top/Parallel

Motor left side parallel type: LEY¹⁶₂₅^L₃₂^L₄₀

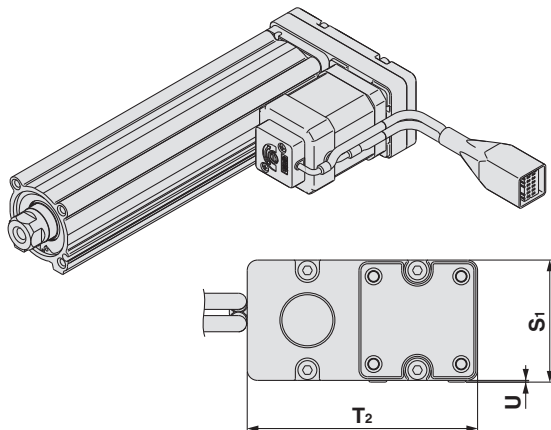

Motor right side parallel type: LEY¹⁶₂₅^R₃₂^R₄₀

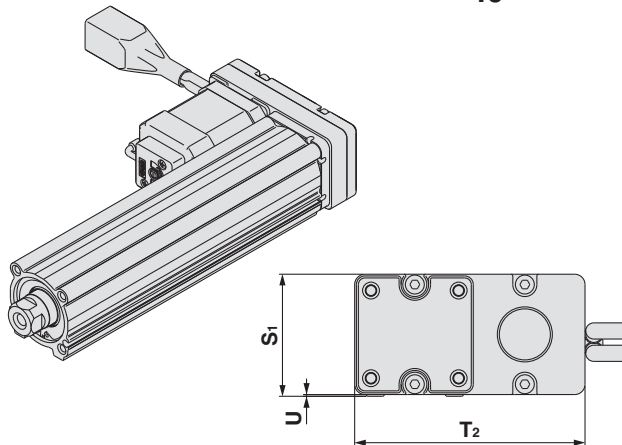

[mm]

Size	S ₁	T ₂	U
16	35.5	67	0.5
25	47	91	1
32, 40	61	117	1

Note) When the motor is mounted on the left or right side in parallel, the groove for auto switch on the side to which the motor is mounted is hidden.

Model Selection

Servo Motor (24 VDC)/Step Motor (Servo/24 VDC)

LEY

LEYG

LECA6
LECP6

LEC-G

LECP1

LECPA

JXC□1

JXC73/83/92/93

AC Servo Motor

LEY

LEYG

LECS□

LECS-T

LECY□

Specific Product Precautions

Series LEY

Step Motor (Servo/24 VDC) Servo Motor (24 VDC)

Dimensions: In-line Motor

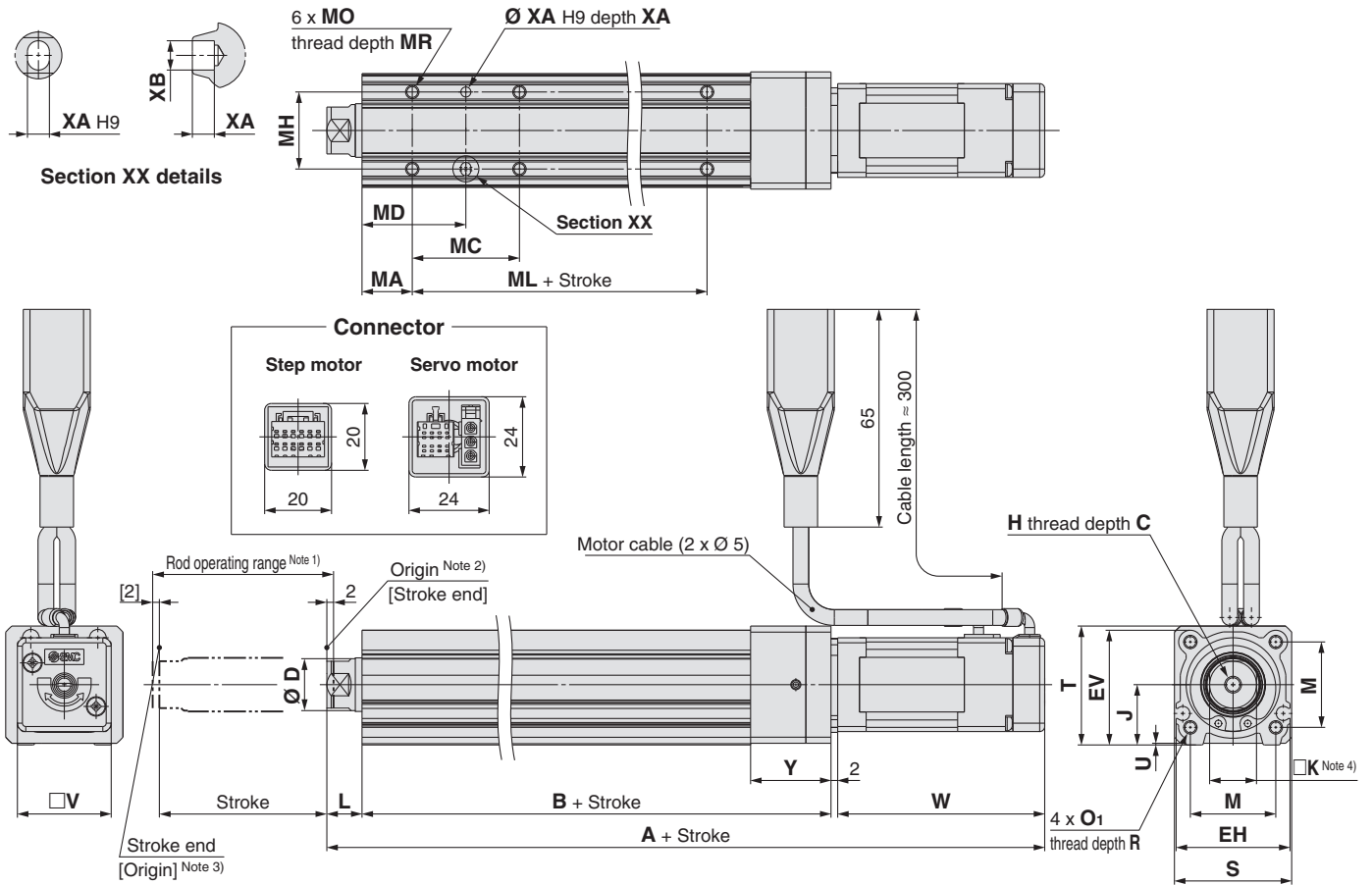

- Note 1) Range within which the rod can move when it returns to origin. Make sure a workpiece mounted on the rod does not interfere with the workpieces and facilities around the rod.
 Note 2) Position after return to origin.
 Note 3) [] for when the direction of return to origin has changed.
 Note 4) The direction of rod end width across flats (□K) differs depending on the products.

Size	Stroke range [mm]	Step motor		Servo motor		B	C	D	EH	EV	H	J	K	L	M	O ₁	R	S	T	U	V	Step motor	Servo motor	Y
		A		W																				
16	10 to 100	166.3	167	92	10	16	34	34.3	M5 x 0.8	18	14	10.5	25.5	M4 x 0.7	7	35	35.5	0.5	28	61.8	62.5	24		
	101 to 300	186.3	187	112	13	20	44	45.5	M8 x 1.25	24	17	14.5	34	M5 x 0.8	8	45	46.5	1.5	42	63.4	59.6	26		
25	15 to 100	195.4	191.6	115.5	13	20	44	45.5	M8 x 1.25	24	17	14.5	34	M5 x 0.8	8	45	46.5	1.5	42	63.4	59.6	26		
	101 to 400	220.4	216.6	140.5	13	25	51	56.5	M8 x 1.25	31	22	18.5	40	M6 x 1	10	60	61	1	56.4	68.4	—	32		
32	20 to 100	216.9	—	128	13	25	51	56.5	M8 x 1.25	31	22	18.5	40	M6 x 1	10	60	61	1	56.4	68.4	—	32		
	101 to 500	246.9	—	158	13	25	51	56.5	M8 x 1.25	31	22	18.5	40	M6 x 1	10	60	61	1	56.4	90.4	—	32		
40	20 to 100	238.9	—	128	13	25	51	56.5	M8 x 1.25	31	22	18.5	40	M6 x 1	10	60	61	1	56.4	90.4	—	32		
	101 to 500	268.9	—	158	13	25	51	56.5	M8 x 1.25	31	22	18.5	40	M6 x 1	10	60	61	1	56.4	90.4	—	32		

Body Bottom Tapped

Size	Stroke range [mm]	MA	MC	MD	MH	ML	MO	MR	XA	XB
16	10 to 39	15	17	23.5	23	40	M4 x 0.7	5.5	3	4
	40 to 100		32	31						
	101 to 300		62	46						
25	15 to 39	20	24	32	29	50	M5 x 0.8	6.5	4	5
	40 to 100		42	41						
	101 to 124		59	49.5						
	125 to 200		76	58						
	201 to 400		76	58						
32 40	20 to 39	25	22	36	30	50	M6 x 1	8.5	5	6
	40 to 100		36	43						
	101 to 124		53	51.5						
	125 to 200		53	51.5						
	201 to 500		70	60						

Dimensions

Motor top/parallel type 16 A
 With motor cover: LEY 25 B-C
 32
 40 C

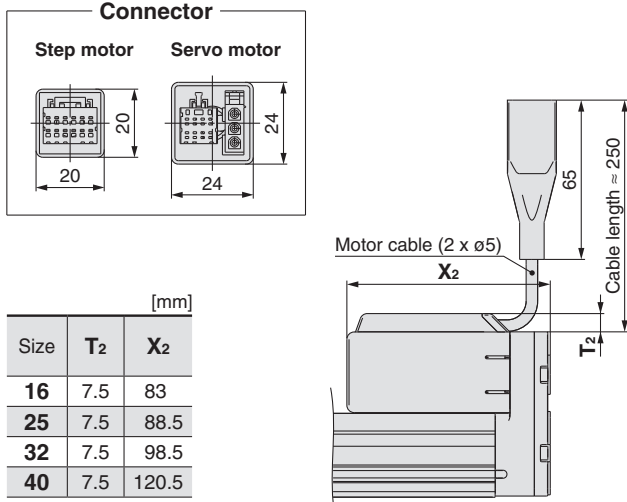

Size	T ₂	X ₂
16	7.5	83
25	7.5	88.5
32	7.5	98.5
40	7.5	120.5

Motor cover material: Synthetic resin

With lock: LEY 16 A
 25 B-C
 32
 40 C

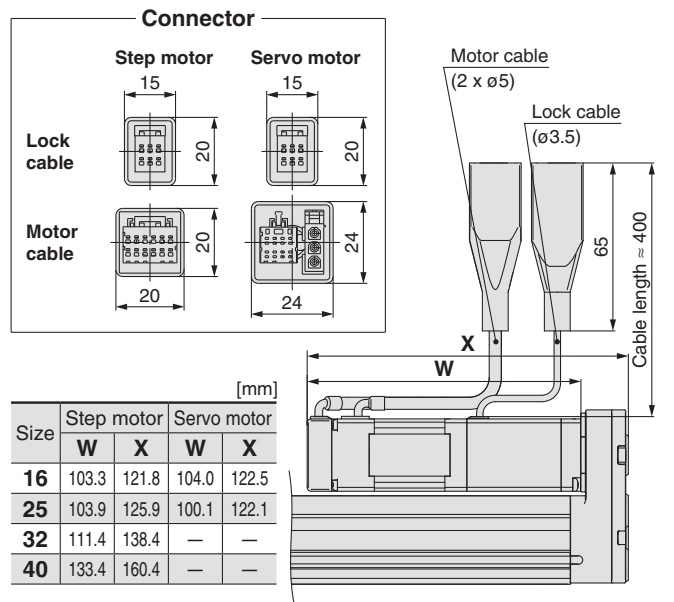

Size	Step motor		Servo motor	
	W	X	W	X
16	103.3	121.8	104.0	122.5
25	103.9	125.9	100.1	122.1
32	111.4	138.4	—	—
40	133.4	160.4	—	—

In-line motor type 16 A
 With motor cover: LEY 25 D B-C
 32 D
 40 C

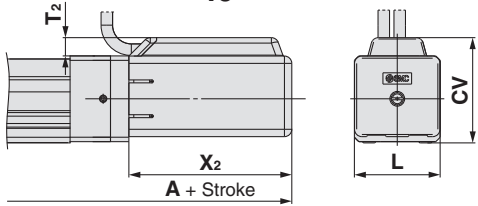

Size	Stroke range	A	T ₂	X ₂	L	CV
16	100st or less	169	7.5	66.5	35	43
	101st or more, 200st or less	189				
25	100st or less	198.5	7.5	68.5	46	54.5
	101st or more, 400st or less	223.5				
32	100st or less	220	7.5	73.5	60	68.5
	101st or more, 500st or less	250				
40	100st or less	242	7.5	95.5	60	68.5
	101st or more, 500st or less	272				

With lock: LEY 16 A
 25 D B-C
 32 D
 40 C

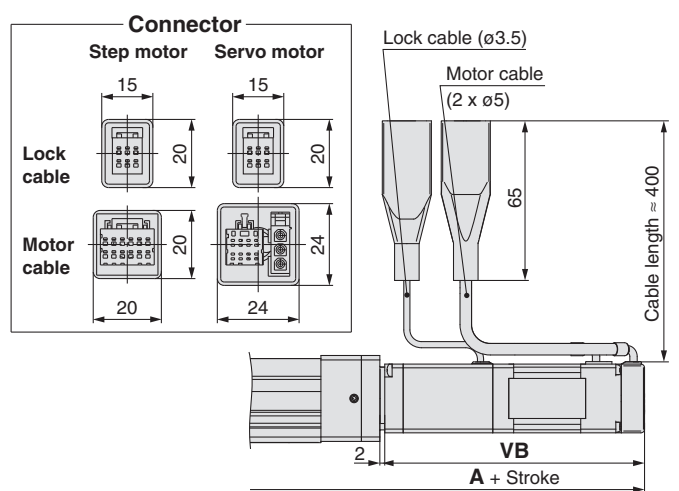

End male thread: LEY 16 A
 25 B-C M
 32 B-C
 40 C

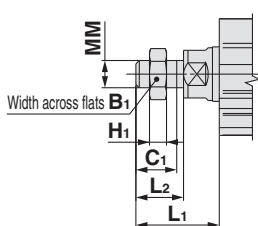

* Refer to page 25 for details about the rod end nut and mounting bracket.
 Note) Refer to the "Handling" precautions on pages 59 to 60 when mounting end brackets such as knuckle joint or workpieces.

Size	B ₁	C ₁	H ₁	L ₁	L ₂	MM
16	13	12	5	24.5	14	M8 x 1.25
25	22	20.5	8	38	23.5	M14 x 1.5
32, 40	22	20.5	8	42.0	23.5	M14 x 1.5

* The L₁ measurement is when the unit is in the original position. At this position, 2 mm at the end.

Size	Stroke range	Step motor		Servo motor	
		A		VB	
16	100st or less	207.8	208.5	103.3	104
	101st or more, 200st or less	227.8	228.5	—	—
25	100st or less	235.9	232.1	103.9	100.1
	101st or more, 400st or less	260.9	257.1	—	—
32	100st or less	259.9	—	111.4	—
	101st or more, 500st or less	289.9	—	—	—
40	100st or less	281.9	—	133.4	—
	101st or more, 500st or less	311.9	—	—	—

Model Selection

LEY

LEYG

LECA6
LECP6

LEC-G

LECP1

LECPA

JXC□1

JXC73/83/92/93

LEY

AC Servo Motor
LEYG

LECS□

LECS-T

LECY□

Specific Product Precautions

Series LEY

Step Motor (Servo/24 VDC)

Servo Motor (24 VDC)

Dimensions

Motor top/parallel type
With lock/motor cover: LEY $\begin{matrix} 16 \\ 25 \\ 32 \\ 40 \end{matrix}$ $\square\square$ B- \square W
 $\begin{matrix} A \\ C \end{matrix}$

In-line motor type
With lock/motor cover: LEY $\begin{matrix} 16 \\ 25 \\ 32 \\ 40 \end{matrix}$ D \square B- \square W
 $\begin{matrix} A \\ C \end{matrix}$

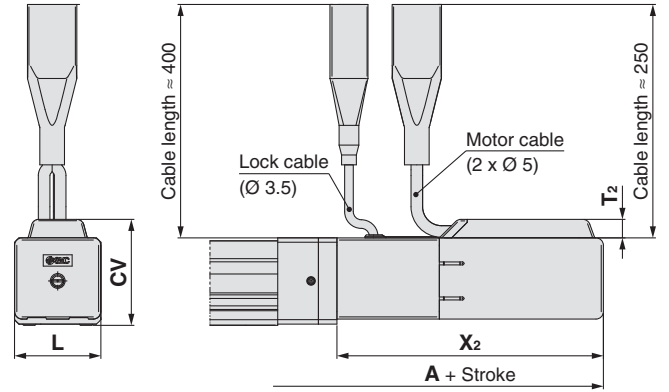
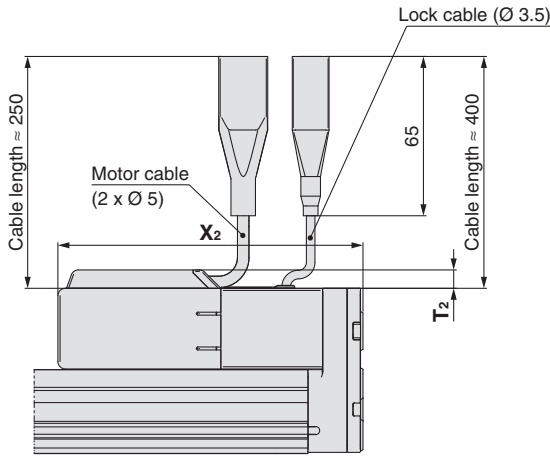

Size	T ₂	X ₂
16	7.5	124.5
25	7.5	129
32	7.5	141.5
40	7.5	163.5

Size	Stroke range	A	T ₂	X ₂	L	CV
16	100st or less	210.5	7.5	108	35	43
	101st or more, 300st or less	230.5				
25	100st or less	239	7.5	109	46	54.4
	101st or more, 400st or less	264				
32	100st or less	263	7.5	116.5	60	68.5
	101st or more, 500st or less	293				
40	100st or less	285	7.5	138.5	60	68.5
	101st or more, 500st or less	315				

Foot: LEY $\begin{matrix} 16 \\ 25 \\ 32 \\ 40 \end{matrix}$ $\square\square$ B- $\square\square$ L
 $\begin{matrix} A \\ C \end{matrix}$

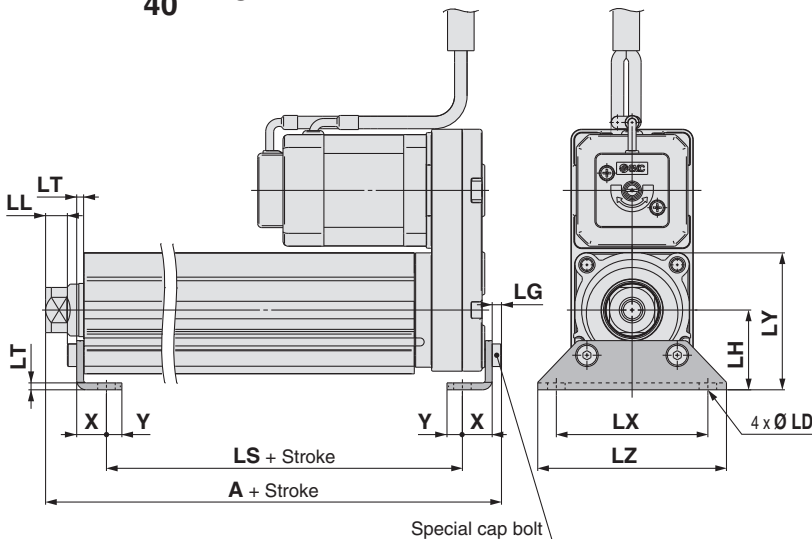

- Included parts
- Foot
 - Body mounting bolt

Size	Stroke range [mm]	A	LS	LS ₁	LL	LD	LG
16	10 to 100	106.1	76.7	16.1	5.4	6.6	2.8
	101 to 300	126.1	96.7				
25	15 to 100	136.6	98.8	19.8	8.4	6.6	3.5
	101 to 400	161.6	123.8				
32	20 to 100	155.7	114	19.2	11.3	6.6	4
40	101 to 500	185.7	144				

Size	Stroke range [mm]	LH	LT	LX	LY	LZ	X	Y
16	10 to 100	24	2.3	48	40.3	62	9.2	5.8
	101 to 300							
25	15 to 100	30	2.6	57	51.5	71	11.2	5.8
	101 to 400							
32	20 to 100	36	3.2	76	61.5	90	11.2	7
40	101 to 500							

Outward mounting

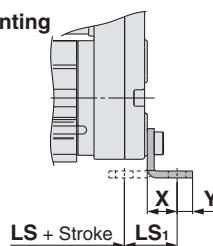

Material: Carbon steel (Chromate treated)
* The A measurement is when the unit is in the original position. At this position, 2 mm at the end.
Note) When the motor mounting is the right or left side parallel type, the head side foot should be mounted outwards.

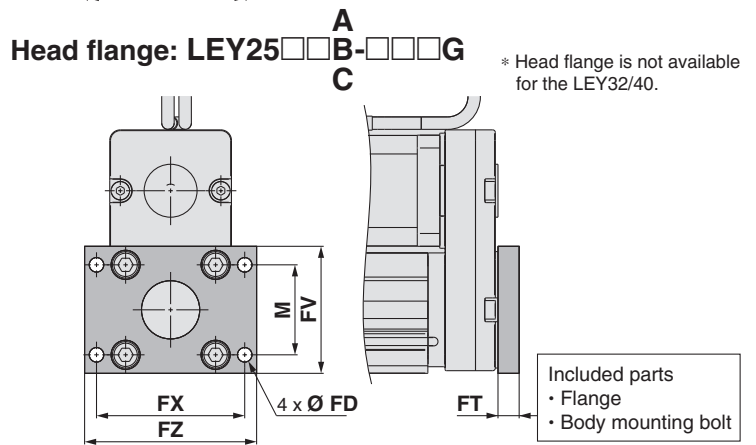
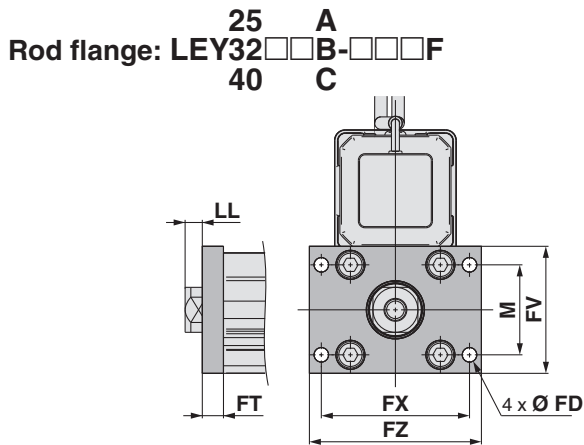
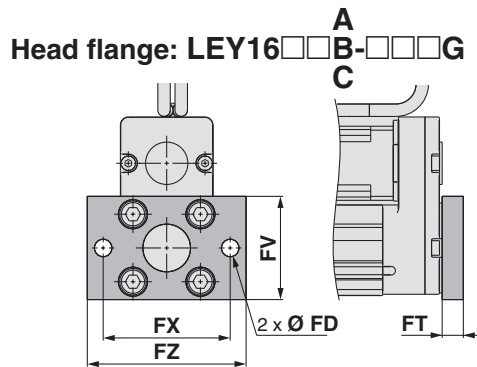
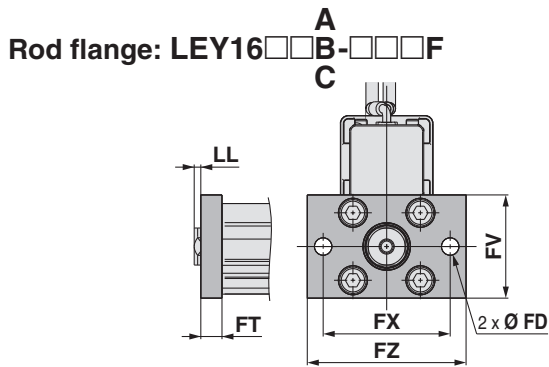

Rod/Head Flange [mm]

Size	FD	FT	FV	FX	FZ	LL	M
16	6.6	8	39	48	60	2.5	—
25	5.5	8	48	56	65	6.5	34
32, 40	5.5	8	54	62	72	10.5	40

Material: Carbon steel (Nickel plated)

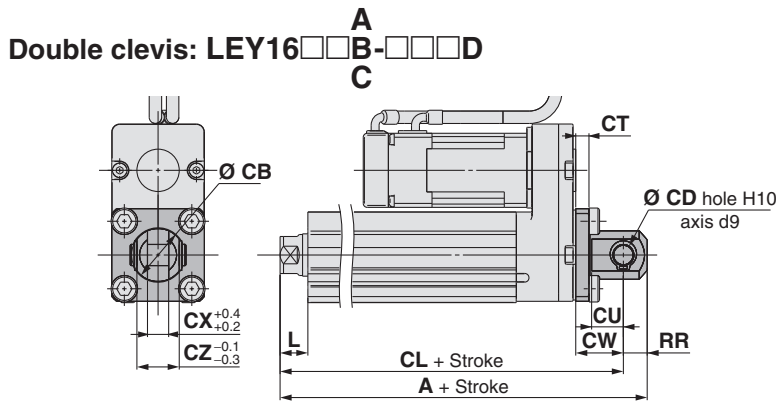

- Included parts
• Double clevis
• Body mounting bolt
• Clevis pin
• Retaining ring

* Refer to page 25 for details about the rod end nut and mounting bracket.

Double Clevis [mm]

Size	Stroke range [mm]	A	CL	CB	CD	CT
16	10 to 100	128	119	20	8	5
	101 to 200	160.5	150.5	—	10	5
25	10 to 100	185.5	175.5	—	10	5
	101 to 200	210.5	200.5	—	10	6

Size	Stroke range [mm]	CU	CW	CX	CZ	L	RR
16	10 to 100	12	18	8	16	10.5	9
	101 to 200	14	20	18	36	14.5	10
25	10 to 100	14	22	18	36	18.5	10
	101 to 200	14	22	18	36	18.5	10

Material: Cast iron (Coating)

* The A and CL measurements are when the unit is in the original position. At this position, 2 mm at the end.

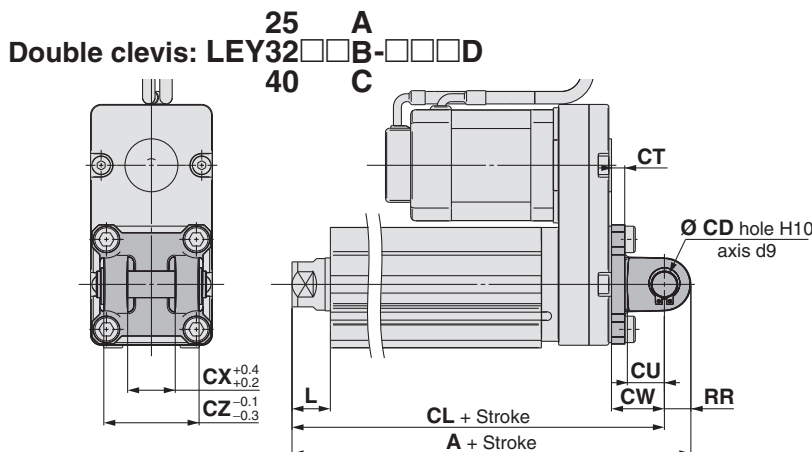

Series LEY Accessory Mounting Brackets

Accessory Brackets/Support Brackets

Single Knuckle Joint

* If a knuckle joint is used, select the body option [end male thread].

I-G02

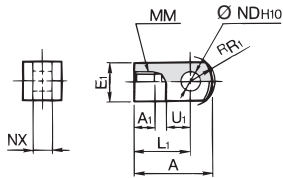

Material: Carbon steel
Surface treatment: Nickel plated

I-G04

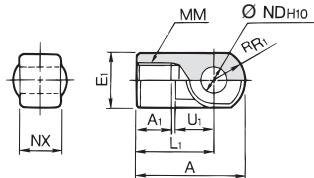

Material: Cast iron
Surface treatment: Nickel plated

Double Knuckle Joint

Y-G02

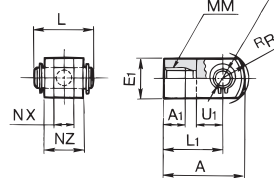

Material: Carbon steel
Surface treatment: Nickel plated

Y-G04

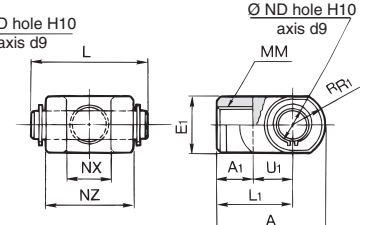

Material: Cast iron
Surface treatment: Nickel plated

Part no.	Applicable size	A	A ₁	E ₁	L ₁	MM	R ₁	U ₁	ND _{H10}	NX
I-G02	16	34	8.5	□16	25	M8 x 1.25	10.3	11.5	8 ^{+0.058} ₀	8 ^{-0.2} _{-0.4}
I-G04	25, 32, 40	42	14	∅ 22	30	M14 x 1.5	12	14	10 ^{+0.058} ₀	18 ^{-0.3} _{-0.5}
I-G05	63	56	18	∅ 28	40	M18 x 1.5	16	20	14 ^{+0.058} ₀	22 ^{-0.3} _{-0.5}

Part no.	Applicable size	A	A ₁	E ₁	L ₁	MM	R ₁
Y-G02	16	34	8.5	□16	25	M8 x 1.25	10.3
Y-G04	25, 32, 40	42	16	∅ 22	30	M14 x 1.5	12
Y-G05	63	56	20	∅ 28	40	M18 x 1.5	16

Knuckle Pin (Common with double clevis pin)

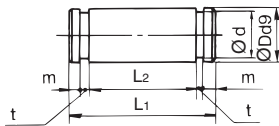

Material: Carbon steel
[mm]

Part no.	Applicable size	Dd9	L ₁	L ₂	d	m	t	Retaining ring
IY-G02	16	8 ^{-0.040} _{-0.076}	21	16.2	7.6	1.5	0.9	Type C retaining ring 8
IY-G04	25, 32, 40	10 ^{-0.040} _{-0.076}	41.6	36.2	9.6	1.55	1.15	Type C retaining ring 10

Part no.	Applicable size	U ₁	ND _{H10}	NX	NZ	L	Applicable pin part no.
Y-G02	16	11.5	8 ^{+0.058} ₀	8 ^{+0.4} _{-0.2}	16	21	IY-G02
Y-G04	25, 32, 40	14	10 ^{+0.058} ₀	18 ^{+0.5} _{-0.3}	36	41.6	IY-G04
Y-G05	63	20	14 ^{+0.058} ₀	22 ^{+0.5} _{-0.3}	44	50.6	IY-G05

Rod End Nut

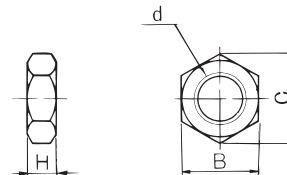

Material: Carbon steel (Nickel plated)
[mm]

Part no.	Applicable size	d	H	B	C
NT-02	16	M8 x 1.25	5	13	15.0
NT-04	25, 32, 40	M14 x 1.5	8	22	25.4
NT-05	63	M18 x 1.5	11	27	31.2

Mounting Brackets/Part No.

Applicable size	Foot	Flange	Double clevis
16	LEY-L016	LEY-F016	LEY-D016
25	LEY-L025	LEY-F025	LEY-D025
32, 40	LEY-L032	LEY-F032	LEY-D032
63	LEY-L063	LEY-F063	LEY-D063

* When ordering foot brackets, order 2 pieces per cylinder.

* Parts belonging to each bracket are as follows.

Foot: Body mounting bolt

Flange: Body mounting bolt

Double clevis: Clevis pin, Type C retaining ring for axis, Body mounting bolt

2-Colour Indication Solid State Auto Switch Direct Mounting Style D-M9NW(V)/D-M9PW(V)/D-M9BW(V)



Refer to SMC website for details about products conforming to the international standards.

PLC: Programmable Logic Controller

Grommet

- 2-wire load current is reduced (2.5 to 40 mA).
- Flexibility is 1.5 times greater than the conventional model (SMC comparison).
- Using flexible cable as standard.
- The optimum operating range can be determined by the colour of the light. (Red → Green ← Red)



Caution

Precautions

Fix the auto switch with the existing screw installed on the auto switch body. The auto switch may be damaged if a screw other than the one supplied is used.

Auto Switch Internal Circuit

D-M9NW/M9NWV

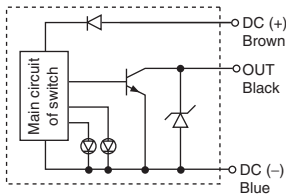

D-M9PW/M9PWV

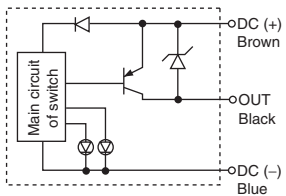

D-M9BW/M9BWV

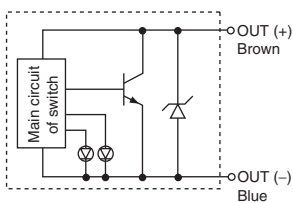

Indicator light/Indication method

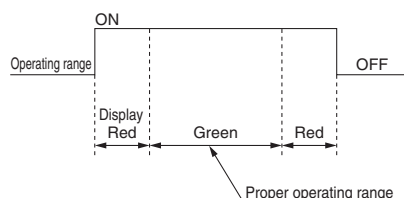

Auto Switch Specifications

D-M9□W, D-M9□WV (With indicator light)						
Auto switch model	D-M9NW	D-M9NWV	D-M9PW	D-M9PWV	D-M9BW	D-M9BWV
Electrical entry	In-line	Perpendicular	In-line	Perpendicular	In-line	Perpendicular
Wiring type	3-wire				2-wire	
Output type	NPN		PNP		—	
Applicable load	IC circuit, Relay, PLC				24 VDC relay, PLC	
Power supply voltage	5, 12, 24 VDC (4.5 to 28 V)				—	
Current consumption	10 mA or less				—	
Load voltage	28 VDC or less		—		24 VDC (10 to 28 VDC)	
Load current	40 mA or less				2.5 to 40 mA	
Internal voltage drop	0.8 V or less at 10 mA (2 V or less at 40 mA)				4 V or less	
Leakage current	100 μA or less at 24 VDC				0.8 mA or less	
Indicator light	Operating range Red LED lights up. Optimum operating range Green LED lights up.					
Standards	CE marking, RoHS					

● Lead wires — Oilproof flexible heavy-duty vinyl cord: Ø 2.7 x 3.2 ellipse, 0.15 mm², 2 cores (D-M9BW(V)), 3 cores (D-M9NW(V), D-M9PW(V))

Note) Refer to Best Pneumatics No. 2 for solid state auto switch common specifications.

Weight

Auto switch model	D-M9NW(V)	D-M9PW(V)	D-M9BW(V)	
Lead wire length [m]	0.5	8	8	7
	1	14	14	13
	3	41	41	38
	5	68	68	63

How to Order

D-M9 N W V L

Series

Wiring/Output type

N	3-wire NPN
P	3-wire PNP
B	2-wire

Lead wire length

—	0.5 m
M	1 m
L	3 m
Z	5 m

Electrical entry

—	In-line
V	Perpendicular

Dimensions

D-M9□W

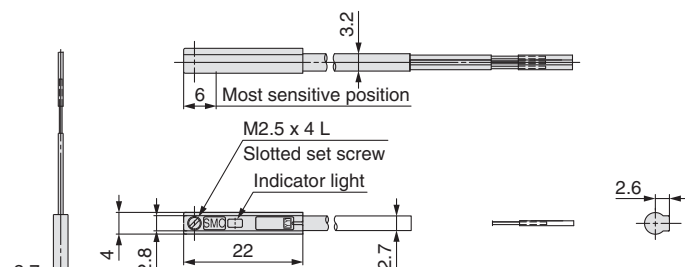

D-M9□WV

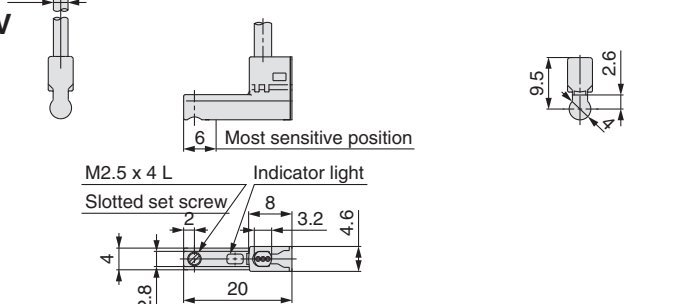

Normally Closed Solid State Auto Switch Direct Mounting Type

D-M9NE(V)/D-M9PE(V)/D-M9BE(V)

Refer to SMC website for the details of the products conforming to the international standards.

PLC: Programmable Logic Controller

Grommet

- Output signal turns on when no magnetic force is detected.
- Can be used for the actuator adopted by the solid state auto switch D-M9 series (excluding special order products)

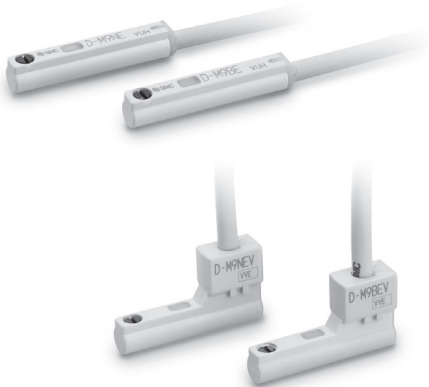

Caution

Precautions

Fix the auto switch with the existing screw installed on the auto switch body. The auto switch may be damaged if a screw other than the one supplied is used.

Auto Switch Specifications

D-M9□E, D-M9□EV (With indicator light)						
Auto switch model	D-M9NE	D-M9NEV	D-M9PE	D-M9PEV	D-M9BE	D-M9BEV
Electrical entry direction	In-line	Perpendicular	In-line	Perpendicular	In-line	Perpendicular
Wiring type	3-wire				2-wire	
Output type	NPN		PNP		—	
Applicable load	IC circuit, Relay, PLC				24 VDC relay, PLC	
Power supply voltage	5, 12, 24 VDC (4.5 to 28 V)				—	
Current consumption	10 mA or less				—	
Load voltage	28 VDC or less		—		24 VDC (10 to 28 VDC)	
Load current	40 mA or less				2.5 to 40 mA	
Internal voltage drop	0.8 V or less at 10 mA (2 V or less at 40 mA)				4 V or less	
Leakage current	100 μA or less at 24 VDC				0.8 mA or less	
Indicator light	Red LED illuminates when turned ON.					
Standard	CE marking, RoHS					

Oilproof Heavy-duty Lead Wire Specifications

Auto switch model		D-M9NE(V)	D-M9PE(V)	D-M9BE(V)
Sheath	Outside diameter [mm]	2.6		
Insulator	Number of cores	3 cores (Brown/Blue/Black)		2 cores (Brown/Blue)
	Outside diameter [mm]	0.88		
Conductor	Effective area [mm ²]	0.15		
	Strand diameter [mm]	0.05		
Minimum bending radius [mm] (Reference values)		17		

Note 1) Refer to the Best Pneumatics No. 2 for solid state auto switch common specifications.
Note 2) Refer to the Best Pneumatics No. 2 for lead wire lengths.

Weight

(g)

Auto switch model		D-M9NE(V)	D-M9PE(V)	D-M9BE(V)
Lead wire length	0.5 m (—)	8	—	7
	1 m (M)*	14	—	13
	3 m (L)	41	—	38
	5 m (Z)*	68	—	63

* The 1 m and 5 m options are produced upon receipt of order.

Dimensions

(mm)

D-M9□E

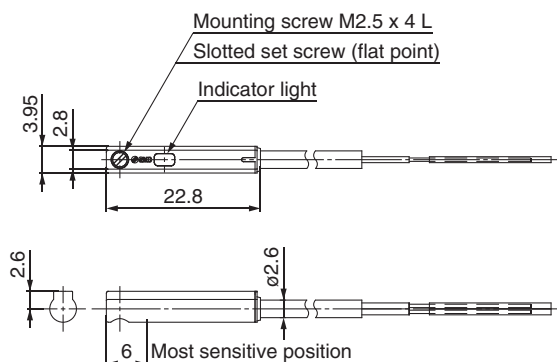

D-M9□EV

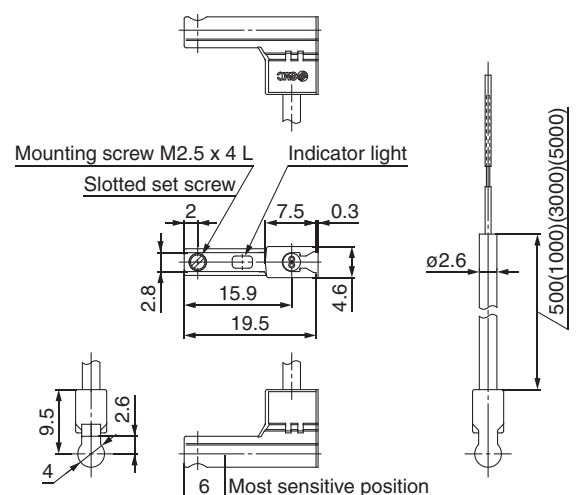

Electric Actuator/Rod Type

Step Motor (Servo/24 VDC) Servo Motor (24 VDC)



Series LEY-X5

Size: 25, 32 Dust/Drip proof (IP65 equivalent)

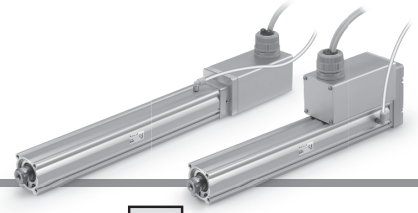

EtherNet/IP IO-Link
DeviceNet EtherCAT Compatible ▶ Page 99

Multi-Axis Step Motor Controller Compatible ▶ Page 108

How to Order

LEY 25 D **B** - **50** - **R 1 6P 1** **X5**

• Dust/Drip proof specification

1 Size

25
32

2 Motor mounting position

—	Top mounting
D	In-line

3 Motor type

Symbol	Type	Size		Compatible controllers/driver
		25	32	
—	Step motor (Servo/24 VDC)	●	●	LECP6 LECP1 LECPA
A	Servo motor (24 VDC)	●	—	LECA6

4 Lead [mm]

Symbol	LEY25	LEY32
A	12	16
B	6	8
C	3	4

5 Stroke [mm]

30	30
to	to
500	500

6 Motor option

—	Without option
B	With lock

7 Rod end thread

—	Rod end female thread
M	Rod end male thread (1 rod end nut is included.)

9 Actuator cable type

R	Robotic cable (Flexible cable)
---	--------------------------------

* Cable is shipped assembled.

10 Actuator cable length [m]

1	1.5	A	10*
3	3	B	15*
5	5	C	20*
8	8		

* Produced upon receipt of order. Refer to the specifications Note 5) on page 7.

11 Controller/Driver type

Without controller/driver		
6N	LECP6/LECA6	NPN
6P	(Step data input type)	PNP
1N*	LECP1	NPN
1P*	(Programmable type)	PNP
AN*	LECPA	NPN
AP*	(Pulse input type)	PNP

* Only available for the motor type "Step motor".

13 Controller/Driver mounting

—	Screw mounting*
D	DIN rail mounting*

Applicable stroke table

Stroke Model	30	50	100	150	200	250	300	350	400	450	500	Manufacturable stroke range [mm]
	●	●	●	●	●	●	●	●	●	●	●	
LEY25	●	●	●	●	●	●	●	●	●	—	—	15 to 400
LEY32	●	●	●	●	●	●	●	●	●	●	●	20 to 500

* Consult with SMC for non-standard strokes as they are produced as special orders.

8 Mounting*1

Symbol	Type	Motor mounting position	
		Top mounting	In-line
—	Ends tapped (Standard)*2	●	●
L	Foot	●	—
F	Rod flange*2	●*3	●
G	Head flange*2	●*4	—

*1 Mounting bracket is shipped together, (but not assembled).

*2 For horizontal cantilever mounting with the rod flange, head flange and ends tapped, use the actuator within the following stroke range.

• LEY25: 200 or less • LEY32: 100 or less

*3 Rod flange is not available for the LEY25/32 with stroke 50 mm or less and motor option "With lock".

*4 Head flange is not available for the LEY32.

12 I/O cable length [m]*1

Without cable	
1	1.5
3	3*2
5	5*2

*1 When "Without controller/driver" is selected for controller/driver types, I/O cable cannot be selected. Refer to page 73 (For LECP6/LECA6), page 86 (For LECP1) or page 93 (For LECPA) if I/O cable is required.

*2 When "Pulse input type" is selected for controller/driver types, pulse input usable only with differential. Only 1.5 m cables usable with open collector.

Caution

[CE-compliant products]

① EMC compliance was tested by combining the electric actuator LEY series and the controller LEC series. The EMC depends on the configuration of the customer's control panel and the relationship with other electrical equipment and wiring. Therefore conformity to the EMC directive cannot be certified for SMC components incorporated into the customer's equipment under actual operating conditions. As a result it is necessary for the customer to verify conformity to the EMC directive for the machinery and equipment as a whole.

② For the servo motor (24 VDC) specification, EMC compliance was tested by installing a noise filter set (LEC-NFA). Refer to page 73 for the noise filter set. Refer to the LECA Operation Manual for installation.

[UL-compliant products]

When conformity to UL is required, the electric actuator and controller/driver should be used with a UL1310 Class 2 power supply.

* For auto switches, refer to page 36.

* "-X5" is not added to an actuator model with a controller/driver part number suffix.

Example) "LEY25DB-100" for the LEY25DB-100BMU-P16NID-X5

The actuator and controller/driver are sold as a package. (Controller/Driver → Page 64)

Confirm that the combination of the controller/driver and the actuator is correct.

<Check the following before use.>

- Check the actuator label for model number. This matches the controller/driver.
- Check Parallel I/O configuration matches (NPN or PNP).



①

②

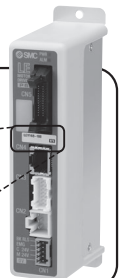

* Refer to the operation manual for using the products. Please download it via our website, <http://www.smcworld.com>

Model Selection
 LEY
 LEYG
 LECA6
 LECP6
 LEC-G
 LEC-P1
 LECPA
 JXC□1
 JXC7□□□□□□□□
 LEY
 LEYG
 LECS□
 LECS-T
 LECY□
 Specific Product Precautions

Series LEY-X5

Step Motor (Servo/24 VDC)

Servo Motor (24 VDC)

Dust/Drip proof (IP65 equivalent)

Specifications

Step Motor (Servo/24 VDC)

Model			LEY25			LEY32			
Stroke [mm] ^{Note 1)}			30, 50, 100, 150, 200 250, 300, 350, 400			30, 50, 100, 150, 200 250, 300, 350, 400, 450, 500			
Work load [kg] ^{Note 2)}	Horizontal	For LEC P6 LECP1 JXC□1	(3000 [mm/s ²])	20	40	60	30	45	60
			(2000 [mm/s ²])	30	60	70	40	60	80
	Vertical ^{Note 15)}	For LEC PA JXC□3	(3000 [mm/s ²])	12	30	30	20	40	40
			(2000 [mm/s ²])	18	50	50	30	60	60
		(3000 [mm/s ²])	7	15	29	10	21	42	
Pushing force [N] ^{Note 3)} ^{Note 4)} ^{Note 5)}			63 to 122	126 to 238	232 to 452	80 to 189	156 to 370	296 to 707	
Speed [mm/s] ^{Note 5)}			18 to 400	9 to 200	5 to 100	24 to 400	12 to 200	6 to 100	
Max. acceleration/deceleration [mm/s ²]			3000						
Pushing speed [mm/s] ^{Note 6)}			35 or less			30 or less			
Positioning repeatability [mm]			±0.02						
Lost motion [mm] ^{Note 7)}			0.1 or less						
Screw lead [mm]			12	6	3	16	8	4	
Impact/Vibration resistance [m/s ²] ^{Note 8)}			50/20						
Actuation type			Ball screw + Belt (LEY□) Ball screw (LEY□D)						
Guide type			Sliding bushing (Piston rod)						
Enclosure ^{Note 9)}			IP65 equivalent						
Operating temperature range [°C]			5 to 40						
Operating humidity range [%RH]			90 or less (No condensation)						
Motor size			□42			□56.4			
Motor type			Step motor (Servo/24 VDC)						
Encoder			Incremental A/B phase (800 pulse/rotation)						
Rated voltage [V]			24 VDC ±10 %						
Power consumption [W] ^{Note 10)}			40			50			
Standby power consumption when operating [W] ^{Note 11)}			15			48			
Max. instantaneous power consumption [W] ^{Note 12)}			48			104			
Type ^{Note 13)}			Non-magnetizing lock						
Holding force [N]			78	157	294	108	216	421	
Power consumption [W] ^{Note 14)}			5			5			
Rated voltage [V]			24 VDC ±10 %						

Note 1) Please consult with SMC for non-standard strokes as they are produced as special orders.

Note 2) Horizontal: The maximum value of the work load. An external guide is necessary to support the load. (Friction coefficient of guide: 0.1 or less) The actual work load and transfer speed change according to the condition of the external guide. Also, speed changes according to the work load. Check "Model Selection" on page 9.

Vertical: Speed changes according to the work load. Check "Model Selection" on page 9.

The values shown in () are the acceleration/deceleration. Set these values to be 3000 [mm/s²] or less.

Note 3) Pushing force accuracy is ±20 % (F.S.).

Note 4) The pushing force values for LEY25□ is 35 % to 65 % and for LEY32□ is 35 % to 85 %. The pushing force values change according to the duty ratio and pushing speed. Check "Model Selection" on page 10.

Note 5) The speed and force may change depending on the cable length, load and mounting conditions. Furthermore, if the cable length exceeds 5 m, then it will decrease by up to 10 % for each 5 m. (At 15 m: Reduced by up to 20 %)

Note 6) The allowable speed for pushing operation. When push conveying a workpiece, operate at the vertical work load or less.

Note 7) A reference value for correcting an error in reciprocal operation.

Note 8) Impact resistance: No malfunction occurred when the actuator was tested with a drop tester in both an axial direction and a perpendicular direction to the lead screw. (Test was performed with the actuator in the initial state.)

Vibration resistance: No malfunction occurred in a test ranging between 45 to 2000 Hz. Test was performed in both an axial direction and a perpendicular direction to the lead screw. (Test was performed with the actuator in the initial state.)

Note 9) Cannot be used in an environment where oil such as cutting oil splashes or it is constantly exposed to water. Take suitable protective measures. .

Note 10) The power consumption (including the controller) is for when the actuator is operating.

Note 11) The standby power consumption when operating (including the controller) is for when the actuator is stopped in the set position during the operation. Except during the pushing operation.

Note 12) The maximum instantaneous power consumption (including the controller) is for when the actuator is operating. This value can be used for the selection of the power supply.

Note 13) With lock only

Note 14) For an actuator with lock, add the power consumption for the lock.

Note 15) When mounting vertically and using the product facing upwards in an environment where water is present, take necessary measures to prevent water from splashing on the rod cover, because water will accumulate on the rod seal due to the structure of the product.

Specifications

Servo Motor (24 VDC)

Model		LEY25A		
Stroke [mm] <small>Note 1)</small>		30, 50, 100, 150, 200 250, 300, 350, 400		
Work load [kg] <small>Note 2)</small>	Horizontal (3000 [mm/s ²])	7	15	30
	Vertical <small>Note 14)</small> (3000 [mm/s ²])	2	5	11
Pushing force [N] <small>Note 3) Note 4)</small>		18 to 35	37 to 72	66 to 130
Speed [mm/s]		2 to 400	1 to 200	1 to 100
Max. acceleration/deceleration [mm/s²]		3000		
Pushing speed [mm/s] <small>Note 5)</small>		35 or less		
Positioning repeatability [mm]		±0.02		
Lost motion [mm] <small>Note 6)</small>		0.1 or less		
Screw lead [mm]		12	6	3
Impact/Vibration resistance [m/s²] <small>Note 7)</small>		50/20		
Actuation type		Ball screw + Belt (LEY□) Ball screw (LEY□D)		
Guide type		Sliding bushing (Piston rod)		
Enclosure <small>Note 8)</small>		IP65 equivalent		
Operating temperature range [°C]		5 to 40		
Operating humidity range [%RH]		90 or less (No condensation)		
Motor size		□42		
Motor type		Servo motor (24 VDC)		
Encoder		Incremental A/B phase (800 pulse/rotation)/Z-phase		
Rated voltage [V]		24 VDC ±10 %		
Power consumption [W] <small>Note 9)</small>		86		
Standby power consumption when operating [W] <small>Note 10)</small>		4 (Horizontal)/12 (Vertical)		
Max. instantaneous power consumption [W] <small>Note 11)</small>		96		
Type <small>Note 12)</small>		Non-magnetizing lock		
Lock unit specifications	Holding force [N]	78	157	294
	Power consumption [W] <small>Note 13)</small>	5		
	Rated voltage [V]	24 VDC ±10 %		

- Note 1)** Please consult with SMC for non-standard strokes as they are produced as special orders.
- Note 2)** Horizontal: The maximum value of the work load. An external guide is necessary to support the load. (Friction coefficient of guide: 0.1 or less) The actual work load and transfer speed change according to the condition of the external guide.
Vertical: Speed changes according to the work load. Check "Model Selection" on page 9. The values shown in () are the acceleration/deceleration. Set these values to be 3000 [mm/s²] or less.
- Note 3)** Pushing force accuracy is ±20 % (F.S.).
- Note 4)** The pushing force values for LEY25A□ is 50 % to 95 %. The pushing force values change according to the duty ratio and pushing speed. Check "Model Selection" on page 10.
- Note 5)** The allowable speed for pushing operation. When push conveying a workpiece, operate at the vertical work load or less.
- Note 6)** A reference value for correcting an error in reciprocal operation.
- Note 7)** Impact resistance: No malfunction occurred when the actuator was tested with a drop tester in both an axial direction and a perpendicular direction to the lead screw. (Test was performed with the actuator in the initial state.)
Vibration resistance: No malfunction occurred in a test ranging between 45 to 2000 Hz. Test was performed in both an axial direction and a perpendicular direction to the lead screw. (Test was performed with the actuator in the initial state.)
- Note 8)** Cannot be used in an environment where oil such as cutting oil splashes or it is constantly exposed to water. Take suitable protective measures.
- Note 9)** The power consumption (including the controller) is for when the actuator is operating.
- Note 10)** The standby power consumption when operating (including the controller) is for when the actuator is stopped in the set position during the operation with the maximum work load. Except during the pushing operation.
- Note 11)** The maximum instantaneous power consumption (including the controller) is for when the actuator is operating. This value can be used for the selection of the power supply.
- Note 12)** With lock only
- Note 13)** For an actuator with lock, add the power consumption for the lock.
- Note 14)** When mounting vertically and using the product facing upwards in an environment where water is present, take necessary measures to prevent water from splashing on the rod cover, because water will accumulate on the rod seal due to the structure of the product.

Weight

Weight: Motor Top Mounting Type

Model		LEY25									LEY32										
Stroke [mm]		30	50	100	150	200	250	300	350	400	30	50	100	150	200	250	300	350	400	450	500
Product weight [kg]	Step motor	1.45	1.52	1.69	1.95	2.13	2.30	2.48	2.65	2.83	2.48	2.59	2.88	3.35	3.64	3.91	4.21	4.49	4.76	5.04	5.32
	Servo motor	1.41	1.48	1.65	1.91	2.09	2.26	2.44	2.61	2.79	—	—	—	—	—	—	—	—	—	—	—

Weight: In-line Motor Type

Model		LEY25D									LEY32D										
Stroke [mm]		30	50	100	150	200	250	300	350	400	30	50	100	150	200	250	300	350	400	450	500
Product weight [kg]	Step motor	1.46	1.53	1.70	1.96	2.14	2.31	2.49	2.66	2.84	2.49	2.60	2.89	3.36	3.65	3.92	4.22	4.50	4.77	5.05	5.33
	Servo motor	1.42	1.49	1.66	1.92	2.10	2.27	2.45	2.62	2.80	—	—	—	—	—	—	—	—	—	—	—

Additional Weight

Size		25	32
Lock		0.33	0.63
Rod end male thread	Male thread	0.03	0.03
	Nut	0.02	0.02
Foot (2 sets including mounting bolt)		0.08	0.14
Rod flange (including mounting bolt)		0.17	0.20
Head flange (including mounting bolt)			

Model Selection

Servo Motor (24 VDC)/Step Motor (Servo/24 VDC)

LEY

LEYG

 LECA6
LECP6

 LEC-G
LEC-G

 LECP1
LECP1

 LECPA
LECPA

JXC□1

JXC73/83/92/93

LEY

LEY

LEYG

LECS□

LECS-T

LECS-T

LECY□

Specific Product Precautions

Dimensions

Motor top mounting type

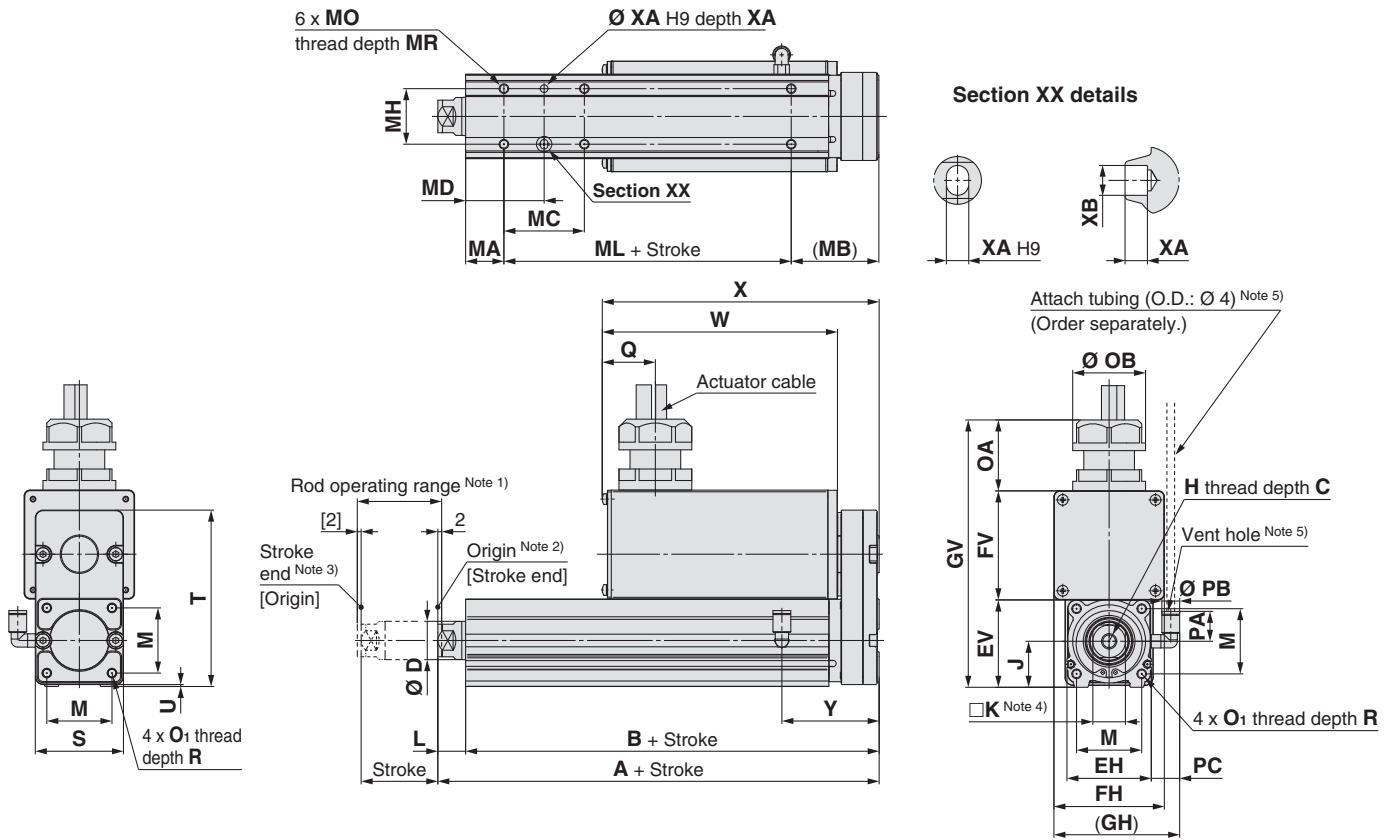

Size	Stroke range [mm]	A	B	C	D	EH	EV	FH	FV	GH	GV	H	J	K	L	M	O ₁
25	15 to 100	130.5	116	13	20	44	45.5	57.6	56.8	66.2	139.5	M8 x 1.25	24	17	14.5	34	M5 x 0.8
	101 to 400	155.5	141														
32	20 to 100	148.5	130	13	25	51	56.5	69.6	78.6	76.2	173.5	M8 x 1.25	31	22	18.5	40	M6 x 1.0
	101 to 500	178.5	160														

Size	Stroke range [mm]	R	OA	OB	PA	PB	Q	S	T	U	PC	W		X		Y
												Without lock	With lock	Without lock	With lock	
25	15 to 100	8	37	38	15.4	8.2	28	46	92	1	15.4	123	173	145	195	51
	101 to 400											123	173	145	195	
32	20 to 100	10	37	38	15.4	8.2	28	60	118	1	15.9	123	173	150	200	61
	101 to 500											123	173	150	200	

Body Bottom Tapped

Size	Stroke range [mm]	MA	MB	MC	MD	MH	ML	MO	MR	XA	XB
25	15 to 39	20	46	24	32	29	50	M5 x 0.8	6.5	4	5
	40 to 100			42	41						
	101 to 124			59	49.5						
	125 to 200			76	58						
	201 to 400			76	58						
32	20 to 39	25	55	22	36	30	50	M6 x 1	8.5	5	6
	40 to 100			36	43						
	101 to 124			53	51.5						
	125 to 200			53	51.5						
	201 to 500			70	60						

- Note 1) Range within which the rod can move when it returns to origin. Make sure a workpiece mounted on the rod does not interfere with the workpieces and facilities around the rod.
 Note 2) Position after return to origin.
 Note 3) [] for when the direction of return to origin has changed.
 Note 4) The direction of rod end width across flats (□K) differs depending on the products.
 Note 5) The vent hole is the port for releasing to atmosphere. Do not apply pressure to this hole. Attach tubing to the vent hole and place the end of the tubing so it is not exposed to dust or water.

For the rod end male thread, refer to page 22. For the mounting bracket dimensions, refer to page 26.

Model Selection

LEY

LEYG

LEYG

LECA6
LECP6

LEC-G

LECP1

LECPA

JXC□1

JXC7303/92/93

AC Servo Motor

LEY

LEYG

LECS□

LECS-T

LECY□

Specific Product Precautions

Series LEY-X5

Step Motor (Servo/24 VDC)

Servo Motor (24 VDC)

Dust/Drip proof (IP65 equivalent)

Dimensions

In-line motor type

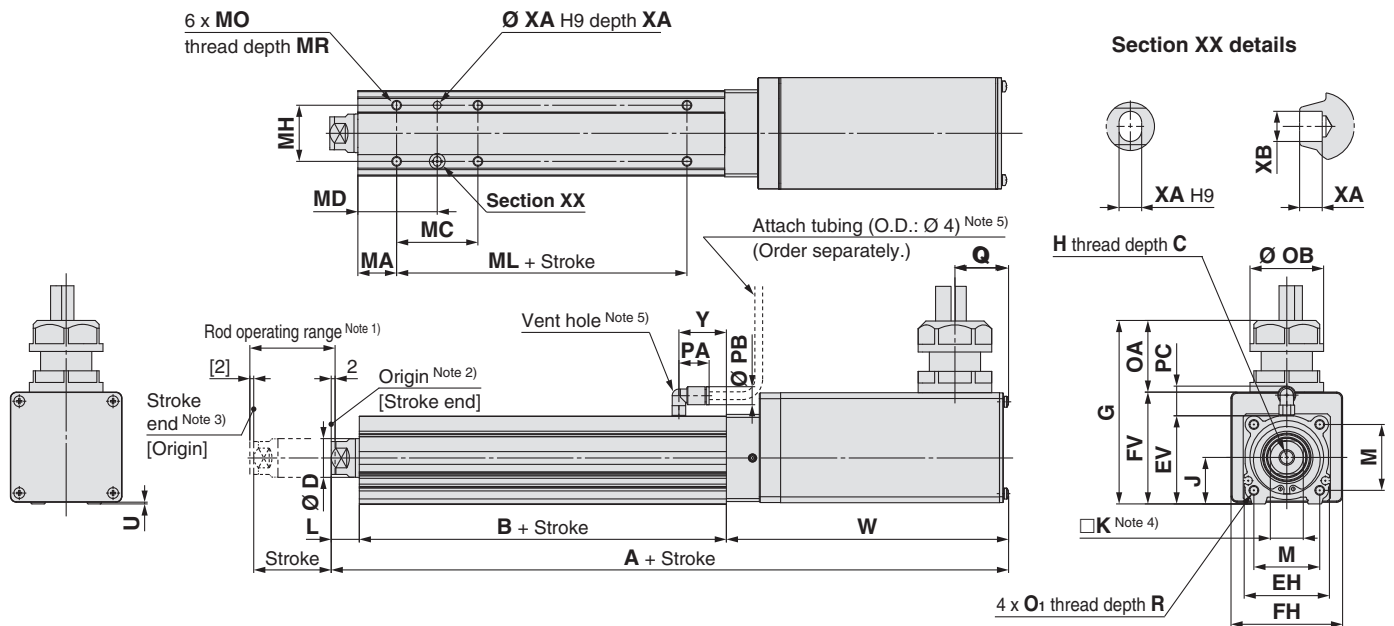

Size	Stroke range [mm]	A		B	C	D	EH	EV	FH	FV	G	H	J	K	L
		Without lock	With lock												
25	15 to 100	250	300	89.5	13	20	44	45.5	57.6	57.7	94.7	M8 x 1.25	24	17	14.5
	101 to 400	275	325	114.5											
32	20 to 100	265.5	315.5	96	13	25	51	56.5	69.6	79.6	116.6	M8 x 1.25	31	22	18.5
	101 to 500	295.5	345.5	126											

Size	Stroke range [mm]	M	O ₁	R	OA	OB	PA	PB	Q	U	PC	W		Y
												Without lock	With lock	
25	15 to 100	34	M5 x 0.8	8	37	38	15.4	8.2	28	0.9	15.9	146	196	24.5
	101 to 400											146	196	
32	20 to 100	40	M6 x 1.0	10	37	38	15.4	8.2	28	1	15.9	151	201	27
	101 to 500											151	201	

Body Bottom Tapped

Size	Stroke range [mm]	MA	MC	MD	MH	ML	MO	MR	XA	XB
25	15 to 39	20	24	32	29	50	M5 x 0.8	6.5	4	5
	40 to 100		42	41		75				
	101 to 124		59	49.5						
	125 to 200		76	58						
	201 to 400		76	58						
32	20 to 39	25	22	36	30	50	M6 x 1	8.5	5	6
	40 to 100		36	43		80				
	101 to 124		53	51.5						
	125 to 200		53	51.5						
	201 to 500		70	60						

Note 1) Range within which the rod can move when it returns to origin. Make sure a workpiece mounted on the rod does not interfere with the workpieces and facilities around the rod.

Note 2) Position after return to origin.

Note 3) [] for when the direction of return to origin has changed.

Note 4) The direction of rod end width across flats (\square K) differs depending on the products.

Note 5) The vent hole is the port for releasing to atmosphere. Do not apply pressure to this hole.

Attach tubing to the vent hole and place the end of the tubing so it is not exposed to dust or water.

For the rod end male thread, refer to page 22. For the mounting bracket dimensions, refer to page 26.

Water Resistant 2-Colour Indication Solid State Auto Switch: Direct Mounting Style D-M9NA(V)/D-M9PA(V)/D-M9BA(V)

Grommet

- Water (coolant) resistant type
- 2-wire load current is reduced (2.5 to 40 mA).
- The optimum operating range can be determined by the colour of the light. (Red → Green ← Red)
- Using flexible cable as standard.



⚠ Caution

Precautions

Fix the auto switch with the existing screw installed on the auto switch body. The auto switch may be damaged if a screw other than the one supplied is used.

Auto Switch Internal Circuit

D-M9NA/M9NAV

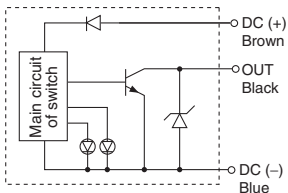

D-M9PA/M9PAV

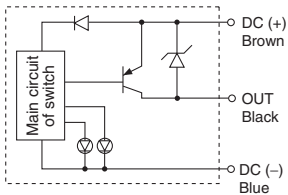

D-M9BA/M9BAV

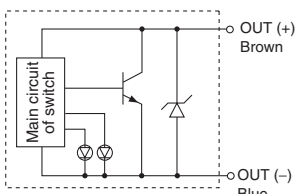

Indicator light/Indication method

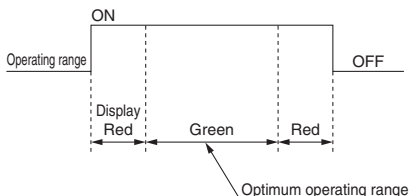

Auto Switch Specifications

PLC: Programmable Logic Controller

D-M9□A, D-M9□AV (With indicator light)						
Auto switch model	D-M9NA	D-M9NAV	D-M9PA	D-M9PAV	D-M9BA	D-M9BAV
Electrical entry	In-line	Perpendicular	In-line	Perpendicular	In-line	Perpendicular
Wiring type	3-wire			2-wire		
Output type	NPN		PNP		—	
Applicable load	IC circuit, Relay, PLC				24 VDC relay, PLC	
Power supply voltage	5, 12, 24 VDC (4.5 to 28 V)				—	
Current consumption	10 mA or less				—	
Load voltage	28 VDC or less		—		24 VDC (10 to 28 VDC)	
Load current	40 mA or less				2.5 to 40 mA	
Internal voltage drop	0.8 V or less at 10 mA (2 V or less at 40 mA)				4 V or less	
Leakage current	100 μA or less at 24 VDC				0.8 mA or less	
Indicator light	Operating range Red LED lights up. Optimum operating range Green LED lights up.					
Standards	CE marking (EMC directive/RoHS directive)					

- Lead wires — Oilproof flexible heavy-duty vinyl cord: \varnothing 2.7 x 3.2 ellipse, 0.15 mm², 2 cores (D-M9BA(V)), 3 cores (D-M9NA(V), D-M9PA(V))

Note 1) Refer to Best Pneumatics No. 2 for solid state auto switch common specifications.

Note 2) Refer to Best Pneumatics No. 2 for lead wire length.

Weight

[g]

Auto switch model	D-M9NA(V)	D-M9PA(V)	D-M9BA(V)
Lead wire length [m]	8	8	7
0.5	8	8	7
1	14	14	13
3	41	41	38
5	68	68	63

Dimensions

[mm]

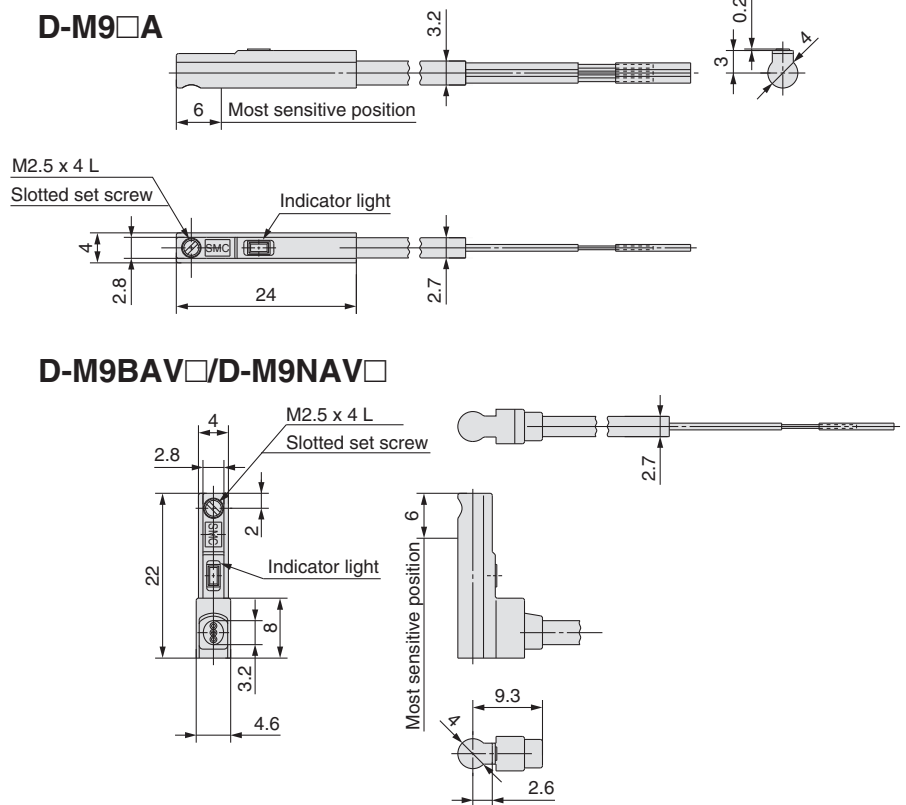

Electric Actuator/Rod Type

Step Motor (Servo/24 VDC)

Servo Motor (24 VDC)

Series 25A-LEY

LEY16, 25, 32, 40



EtherNet/IP IO-Link
DeviceNet EtherCAT Compatible ▶ Page 99

Multi-Axis Step Motor Controller Compatible ▶ Page 108

How to Order

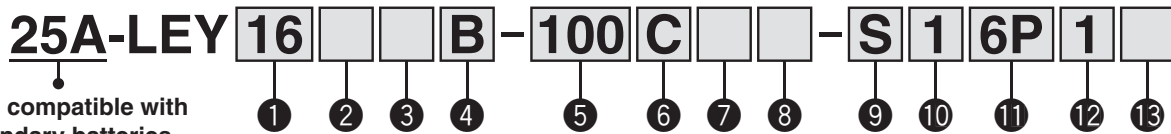

1 Size

16
25
32
40

2 Motor mounting position

—	Top mounting
R	Right side parallel
L	Left side parallel
D	In-line

3 Motor type

Symbol	Type	Size			Compatible controllers/driver
		LEY16	LEY25	LEY32/40	
—	Step motor (Servo/24 VDC)	●	●	●	LECP6 LECP1 LECPA
A	Servo motor (24 VDC)	●	●	—	LECA6

4 Lead [mm]

Symbol	LEY16	LEY25	LEY32/40
A	10	12	16
B	5	6	8
C	2.5	3	4

5 Stroke [mm]

30	30
to	to
500	500

* Refer to the applicable stroke table.

6 Motor option

C	With motor cover
W	With lock/motor cover

* When "With lock/motor cover" is selected for the top mounting and right/left side parallel types, the motor body will stick out of the end of the body for size 16 with strokes 30 or less. Check for interference with workpieces before selecting a model.

7 Rod end thread

—	Female rod end
M	Male rod end (1 rod end nut is included.)

⚠ Caution

[CE-compliant products]

① EMC compliance was tested by combining the electric actuator LEY series and the controller LEC series.

The EMC depends on the configuration of the customer's control panel and the relationship with other electrical equipment and wiring. Therefore conformity to the EMC directive cannot be certified for SMC components incorporated into the customer's equipment under actual operating conditions. As a result it is necessary for the customer to verify conformity to the EMC directive for the machinery and equipment as a whole.

② For the servo motor (24 VDC) specification, EMC compliance was tested by installing a noise filter set (LEC-NFA). Refer to the website www.smc.eu for the noise filter set. Refer to the LECA Operation Manual for installation.

[UL-compliant products]

When conformity to UL is required, the electric actuator and controller/driver should be used with a UL1310 Class 2 power supply.

Mounting Bracket Part No. for Series 25A-

Applicable size	Foot *1	Flange	Double clevis
16	25-LEY-L016	25-LEY-F016	25-LEY-D016
25	25-LEY-L025	25-LEY-F025	25-LEY-D025
32, 40	25-LEY-L032	25-LEY-F032	25-LEY-D032
Surface treatment	RAYDENT®	RAYDENT®	Coating (Size 16: Electroless nickel plating)

*1 When ordering foot brackets, order 2 pieces per actuator.

*2 Parts belonging to each bracket are as follows.

Foot, Flange: Body mounting bolt, Double clevis: Clevis pin, Type C retaining ring for axis, Body mounting bolt

* Applicable stroke table

● Standard

Stroke [mm]	30	50	100	150	200	250	300	350	400	450	500	Manufacturable stroke range [mm]
Model												
LEY16	●	●	●	●	●	●	●	—	—	—	—	10 to 300
LEY25	●	●	●	●	●	●	●	●	●	—	—	15 to 400
LEY32/40	●	●	●	●	●	●	●	●	●	●	●	20 to 500

* Consult with SMC for non-standard strokes as they are produced as special orders.

For details about auto switches, refer to "Series Compatible with Secondary Batteries".

Applicable auto switches

D-M9N(V)-900, D-M9P(V)-900, D-M9B(V)-900
D-M9NW(V)-900, D-M9PW(V)-900, D-M9BW(V)-900

The actuator and controller/driver are sold as a package.

Confirm that the combination of the controller/driver and the actuator is correct.

<Check the following before use.>

- Check the actuator label for model number (after "25A-"). This matches the controller/driver.
- Check Parallel I/O configuration matches (NPN or PNP)

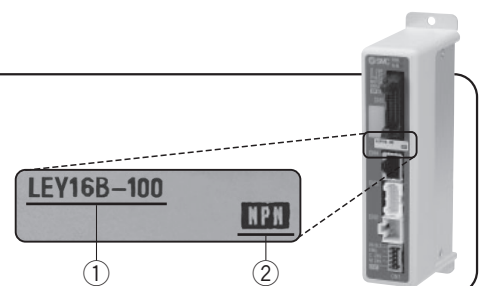

* Refer to the operation manual for using the products. Please download it via our website, <http://www.smc.eu>

Electric Actuator/Rod Type **Series 25A-LEY**

Step Motor (Servo/24 VDC)

Servo Motor (24 VDC)

Secondary Battery Compatible

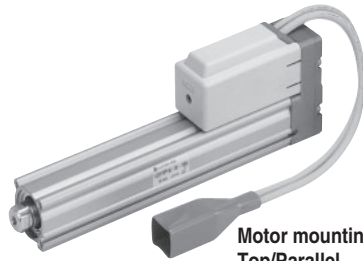

Motor mounting position:
Top/Parallel

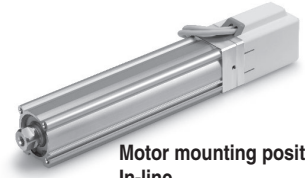

Motor mounting position:
In-line

8 Mounting*1

Symbol	Type	Motor mounting position	
		Top/Parallel	In-line
—	Ends tapped (Standard)*2	●	●
L	Foot	●	—
F	Rod flange*2	●	●
G	Head flange*2	●*4	—
D	Double clevis*3	●	—

*1 Mounting bracket is shipped together, (but not assembled).

*2 For horizontal cantilever mounting with the rod flange, head flange and ends tapped, use the actuator within the following stroke range.

- LEY25: 200 or less
- LEY32/40: 100 or less

*3 For mounting with the double clevis, use the actuator within the following stroke range.

- LEY16: 100 or less
- LEY25: 200 or less
- LEY32/40: 200 or less

*4 Head flange is not available for the LEY32/40.

13 Controller/Driver mounting

—	Screw mounting
D	DIN rail mounting*1

*1 DIN rail is not included. Order it separately.

9 Actuator cable type*1

—	Without cable
S	Standard cable*2
R	Robotic cable (Flexible cable)*3

*1 The standard cable should be used on fixed parts. For using on moving parts, select the robotic cable.

*2 Only available for the motor type "Step motor".

*3 Fix the motor cable protruding from the actuator to keep it unmovable. For details about fixing method, refer to Wiring/Cables in the Electric Actuators Precautions.

11 Controller/Driver type*1

—	Without controller/driver	
6N	LECP6/LECA6 (Step data input type)	NPN
6P		PNP
1N	LECP1*2 (Programless type)	NPN
1P		PNP
AN	LECPA*3 (Pulse input type)	NPN
AP		PNP

*1 For details about controllers/driver and compatible motors, refer to the compatible controllers/driver below.

*2 Only available for the motor type "Step motor".

*3 When pulse signals are open collector, order the current limit resistor (LEC-PA-R-□) separately.

10 Actuator cable length [m]

—	Without cable
1	1.5
3	3
5	5
8	8*
A	10*
B	15*
C	20*

* Produced upon receipt of order (Robotic cable only)

12 I/O cable length [m]*1, Communication plug

—	Without cable (Without communication plug connector)
1	1.5
3	3*2
5	5*2

*1 When "Without controller/driver" is selected for controller/driver types, I/O cable cannot be selected. Refer LEY catalogue if I/O cable is required.

*2 When "Pulse input type" is selected for controller/driver types, pulse input usable only with differential. Only 1.5 m cables usable with open collector.

Compatible Controllers/Driver

Type	Step data input type	Step data input type	Programless type	Pulse input type
Series	LECP6		LECA6	LECP1
Features	Value (Step data) input Standard controller		Capable of setting up operation (step data) without using a PC or teaching box	Operation by pulse signals
Compatible motor	Step motor (Servo/24 VDC)	Servo motor (24 VDC)	Step motor (Servo/24 VDC)	
Maximum number of step data	64 points		14 points	—
Power supply voltage	24 VDC			

* Copper and zinc materials are used for the motors, cables, controllers/drivers.

* Specifications and dimensions for the 25A-series are the same as standard products.



Series 25A-LE □

Precautions

Be sure to read before handling.

Handling

Caution

■ Change of material

Series 25A- are copper- and zinc-free products, however, some parts including coils for motors, cables, drivers and auto switches, and connector pins and lead wires, whose material can not be changed, are made of copper.

■ Chemical environment

Refrain from using the products in such environments as exposed to chemicals. Otherwise, resin parts may deteriorate. If you want SMC to test the products for the effects of chemicals attached to them, send the products back to SMC after thoroughly cleaning them. Consult your SMC sales representative for further details.

■ Trademark

DeviceNet™ is a trademark of ODVA.

EtherCAT® is registered trademark and patented technology, licensed by Beckhoff Automation GmbH, Germany.

Be sure to read "Handling Precautions for SMC Products" (M-E03-3) and "Operation Manual" before using.

Series **LEYG**

Model Selection

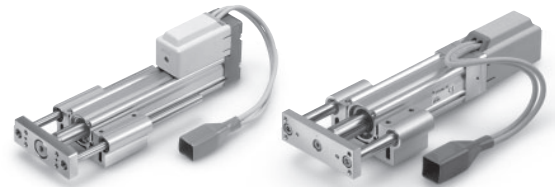

Moment Load Graph

Selection conditions

Mounting position	Vertical		Horizontal	
Max. speed [mm/s]	"Speed-Vertical Work Load Graph"		200 or less	Over 200
Graph (Sliding bearing type)	①, ②		⑤, ⑥*	—
Graph (Ball bushing bearing type)	③, ④		⑦, ⑧	⑨, ⑩

* For the sliding bearing type, the speed is restricted with a horizontal/moment load.

Vertical Mounting, Sliding Bearing

① 70 stroke or less

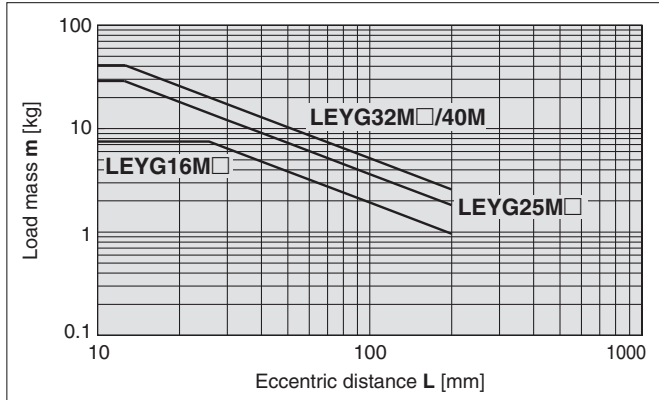

② Over 75 stroke

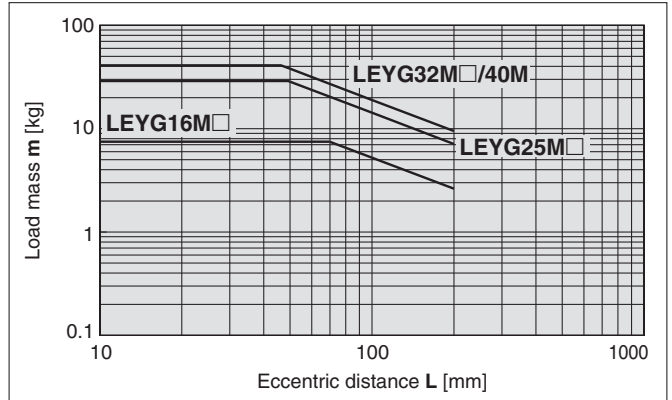

* The limit of vertical load mass varies depending on "lead" and "speed". Check "Speed-Vertical Work Load Graph" on page 42.

Vertical Mounting, Ball Bushing Bearing

③ 35 stroke or less

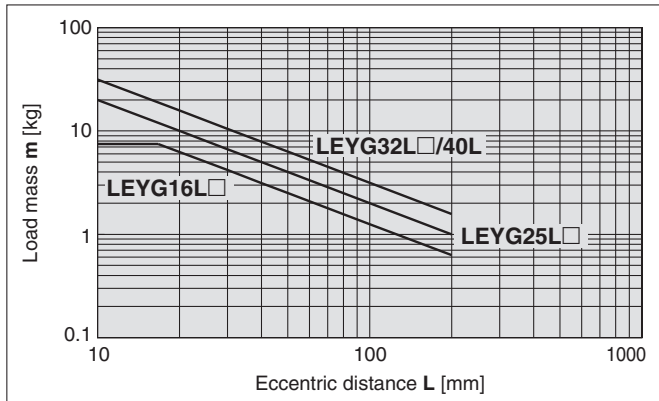

④ Over 40 stroke

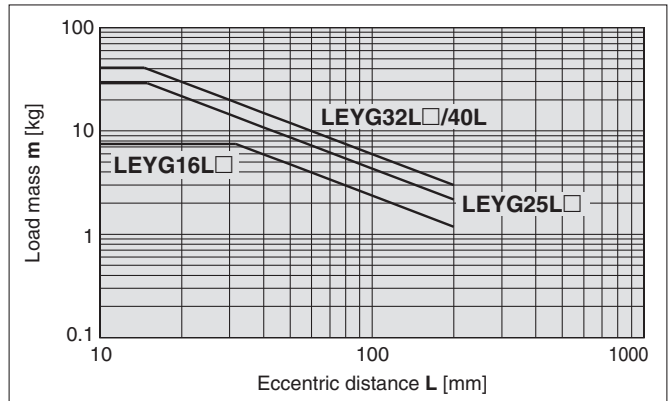

* The limit of vertical load mass varies depending on "lead" and "speed". Check "Speed-Vertical Work Load Graph" on page 42.

Model Selection

Servo Motor (24 VDC)/Step Motor (Servo/24 VDC)

LEY

LEYG

LECA6
LECP6

LEC-G
LECP6

LECP1
LECP1

LECPA
LECPA

JXC□1

JXC7303/9293

LEY

AC Servo Motor

LEYG

LECS□

LECS-T

LECY□

Specific Product Precautions

Series LEYG

Step Motor (Servo/24 VDC) Servo Motor (24 VDC)

Moment Load Graph

Horizontal Mounting, Sliding Bearing

⑤ L = 50 mm

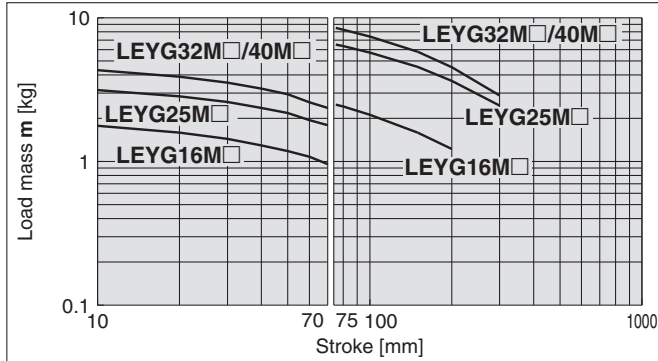

⑥ L = 100 mm

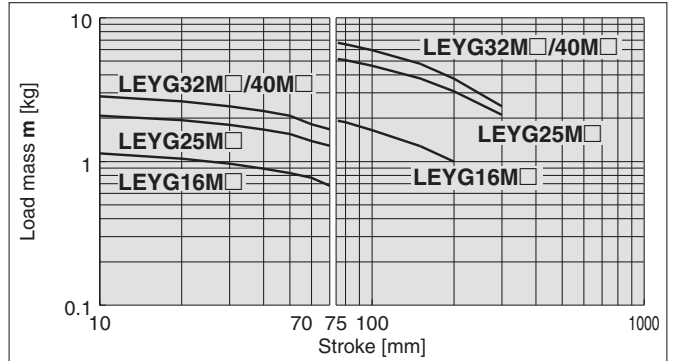

* Set the speed to less than or equal to the values shown below.

Motor type	LEYG□M□A	LEYG□M□B	LEYG□M□C
Step motor (Servo/24 VDC)	200 mm/s	125 mm/s	75 mm/s
Servo motor (24 VDC)	200 mm/s	200 mm/s	125 mm/s

* For the specifications below, operate the system at the "load mass" shown in the graph x 80 %.

- LEYG25MAA/Servo motor (24 VDC), Lead 12

Horizontal Mounting, Ball Bushing Bearing

⑦ L = 50 mm Max. speed = 200 mm/s or less

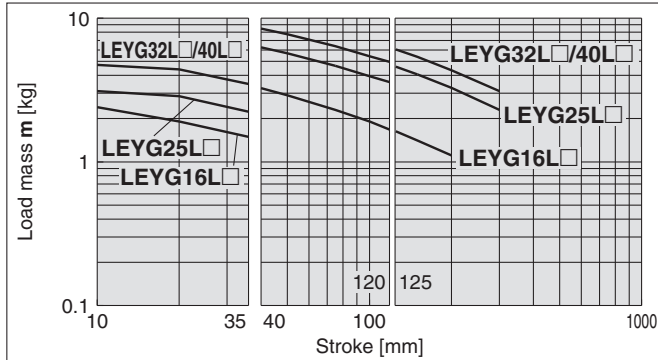

⑧ L = 100 mm Max. speed = 200 mm/s or less

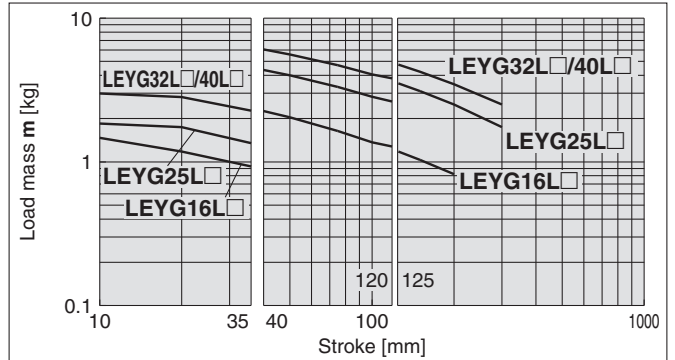

⑨ L = 50 mm Max. speed = Over 200 mm/s

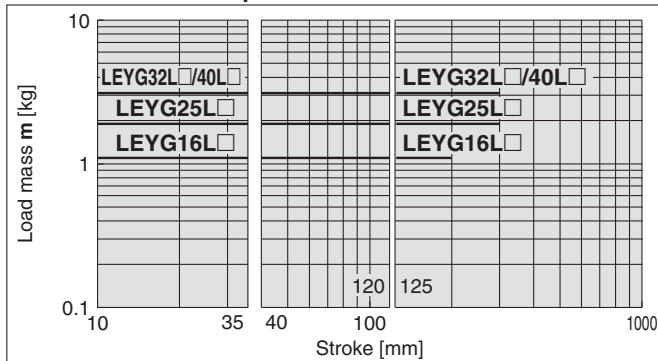

⑩ L = 100 mm Max. speed = Over 200 mm/s

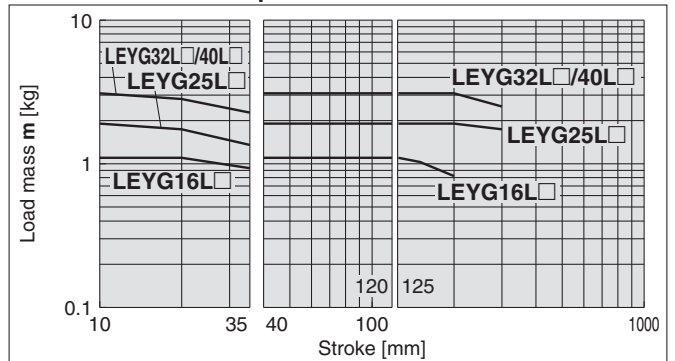

Operating Range when Used as Stopper

LEYG□M (Sliding bearing)

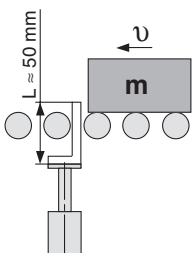

⚠ Caution

Handling Precautions

- Note 1) When used as a stopper, select a model with 30 stroke or less.
- Note 2) LEYG□L (ball bushing bearing) cannot be used as a stopper.
- Note 3) Workpiece collision in series with guide rod cannot be permitted (Fig. a).
- Note 4) The body should not be mounted on the end. It must be mounted on the top or bottom (Fig. b).

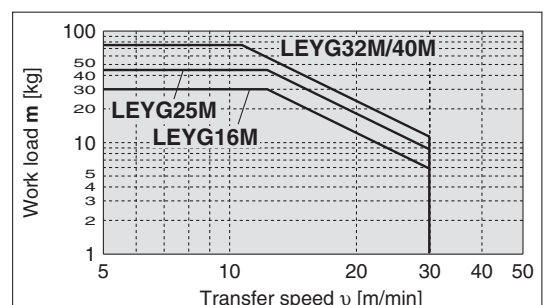
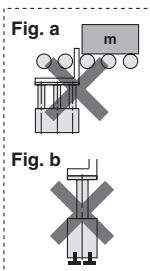

Speed-Work Load Graph (Guide)

For Step Motor (Servo/24 VDC) LECP6, LECP1, JXC1/91/P1/D1/L1

Horizontal

LEYG16^M_L for acceleration/deceleration: 2000 mm/s²

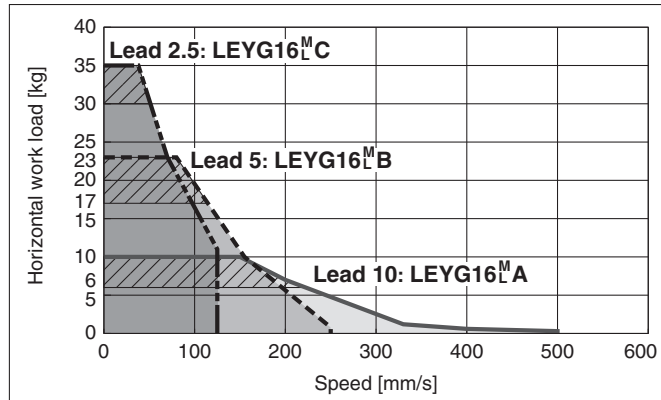

LEYG25^M_L for acceleration/deceleration: 2000 mm/s²

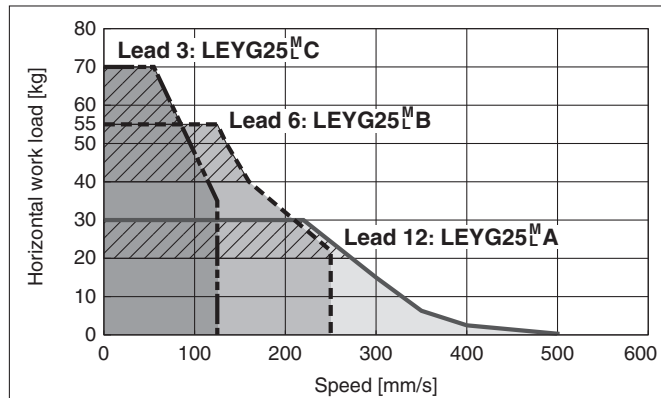

LEYG32^M_L for acceleration/deceleration: 2000 mm/s²

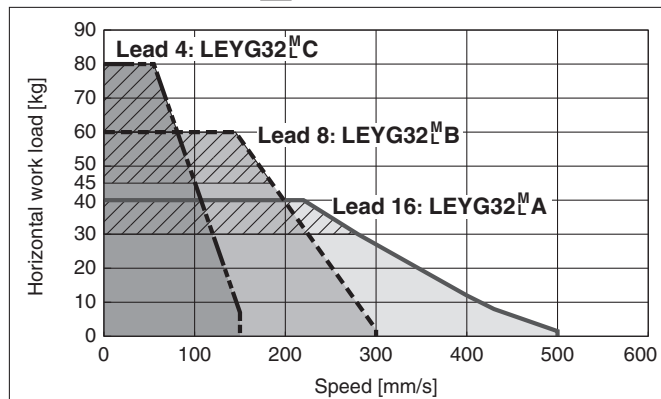

LEYG40^M_L for acceleration/deceleration: 2000 mm/s²

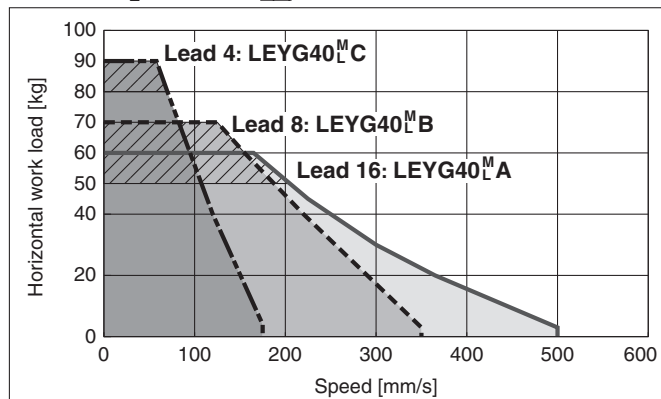

Vertical

LEYG16^M_L

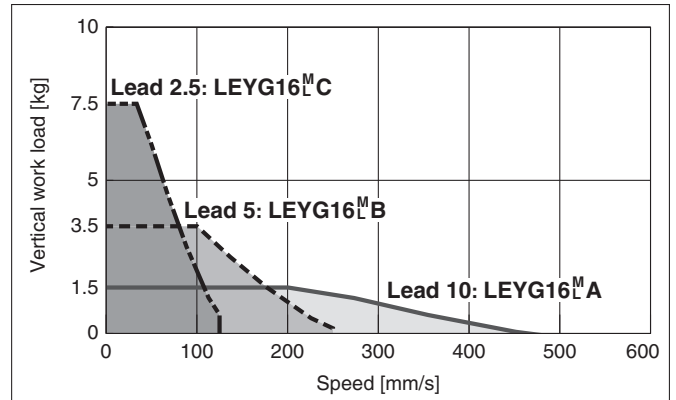

LEYG25^M_L

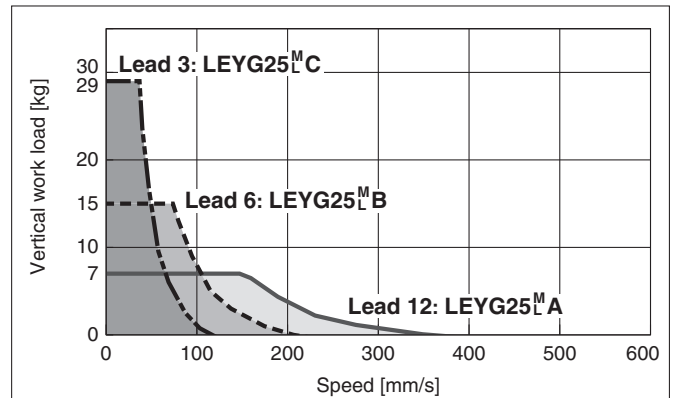

LEYG32^M_L

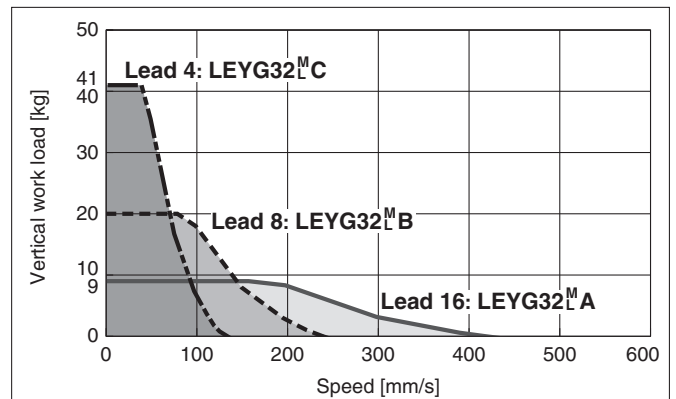

LEYG40^M_L

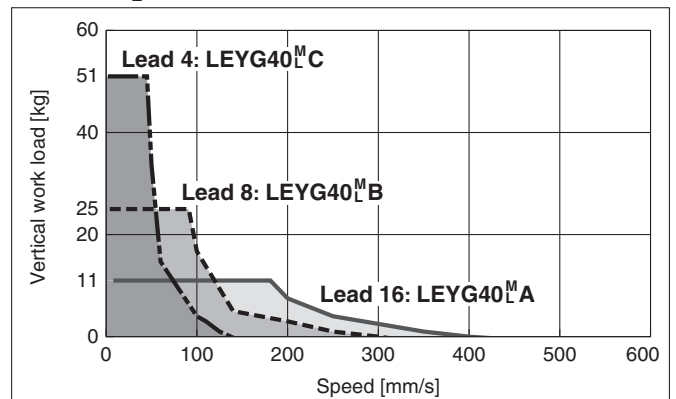

Model Selection

LEY

LEYG

LECA6

LECP6

LEC-G

LECP1

LECPA

JXC□1

JXC7□□□□□□□□

LEY

LEY

LEYG

LECS□

LECS-T

LECY□

Specific Product Precautions

Series LEYG

Step Motor (Servo/24 VDC) Servo Motor (24 VDC)

Speed-Work Load Graph (Guide) For Step Motor (Servo/24 VDC) LECPA, JXC73/83/92/93

Horizontal

LEYG16^M_L □  for acceleration/deceleration: 2000 mm/s²

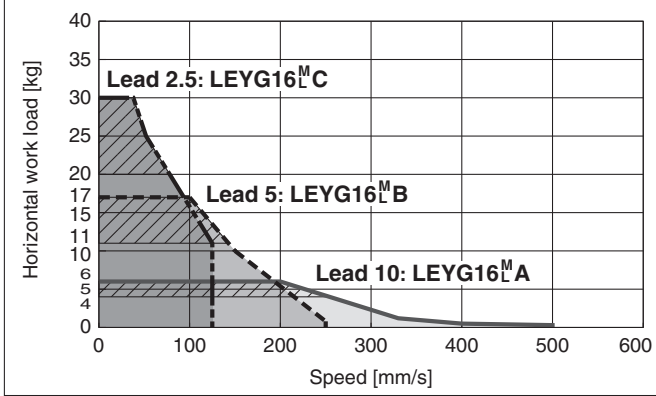

LEYG25^M_L □  for acceleration/deceleration: 2000 mm/s²

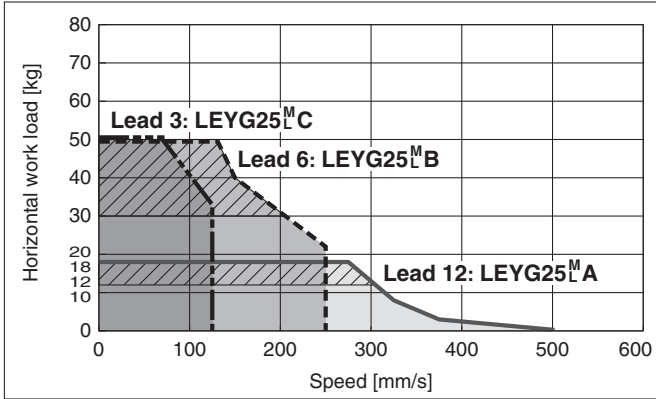

LEYG32^M_L □  for acceleration/deceleration: 2000 mm/s²

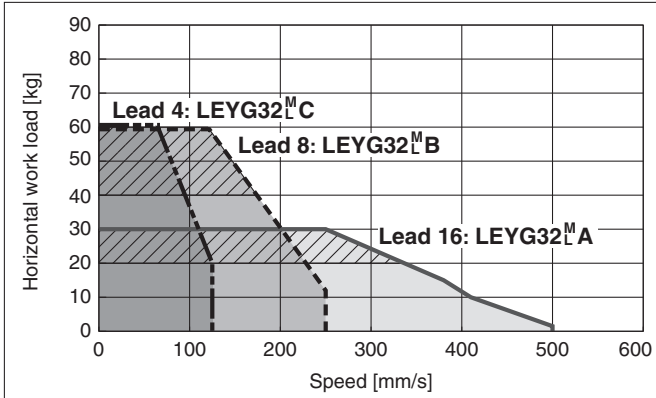

LEYG40^M_L □  for acceleration/deceleration: 2000 mm/s²

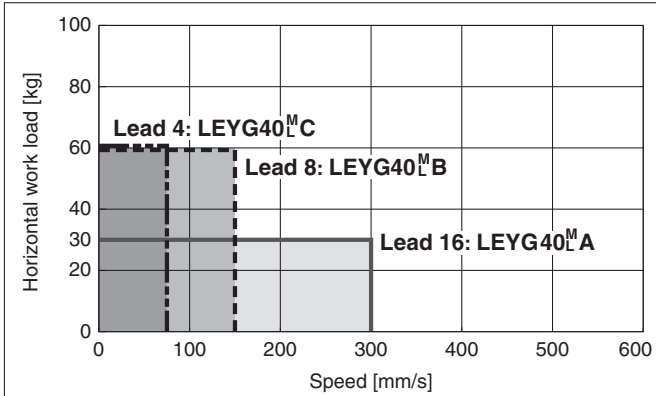

Vertical

LEYG16^M_L □

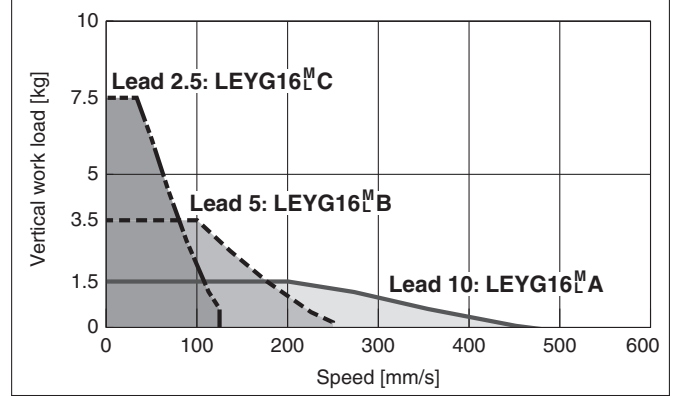

LEYG25^M_L □

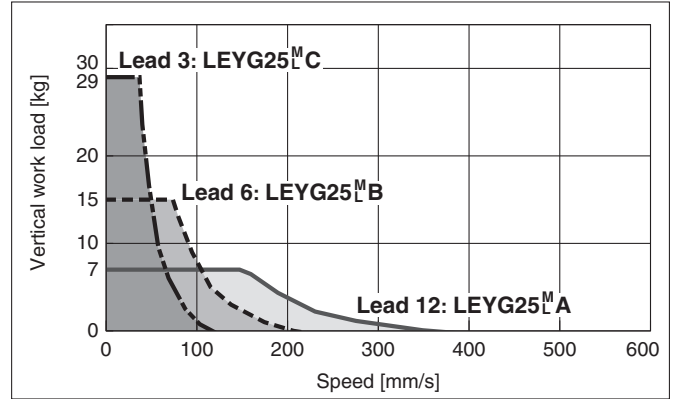

LEYG32^M_L □

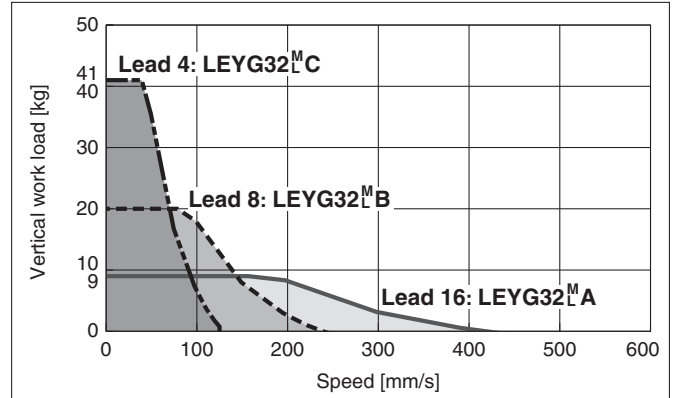

LEYG40^M_L □

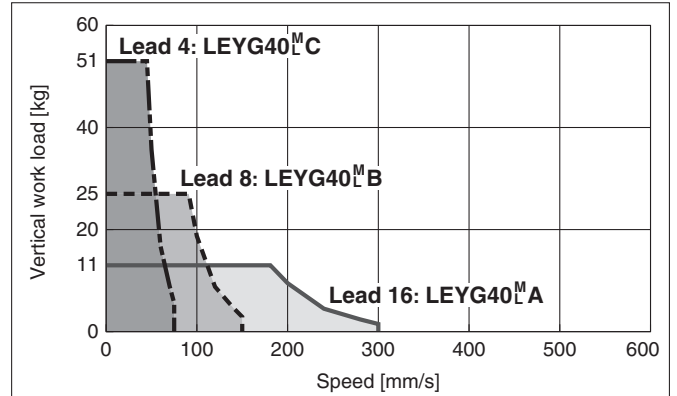

Speed-Work Load Graph (Guide) For Servo Motor (24 VDC) LECA6

Horizontal

LEYG16^MA□

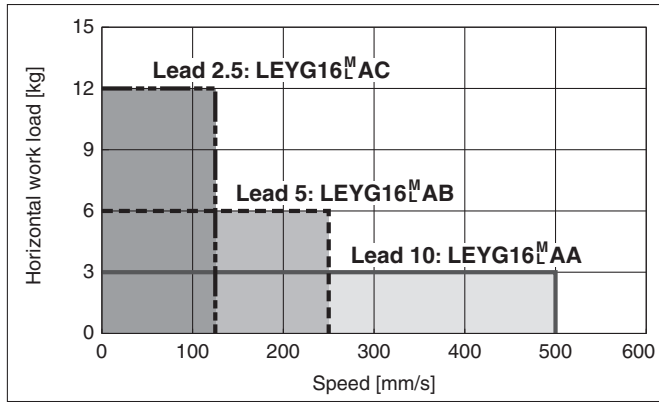

LEYG25^MA□

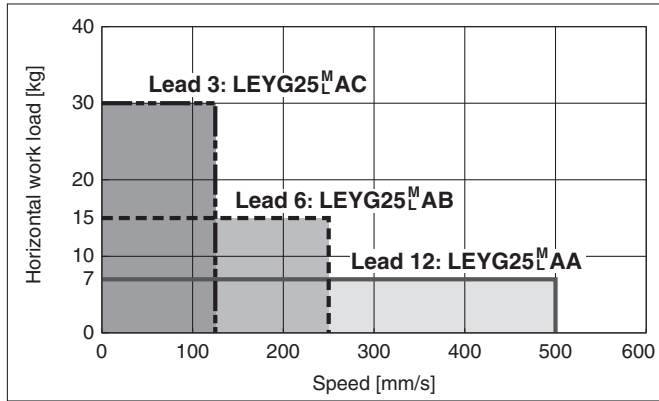

Vertical

LEYG16^MA□

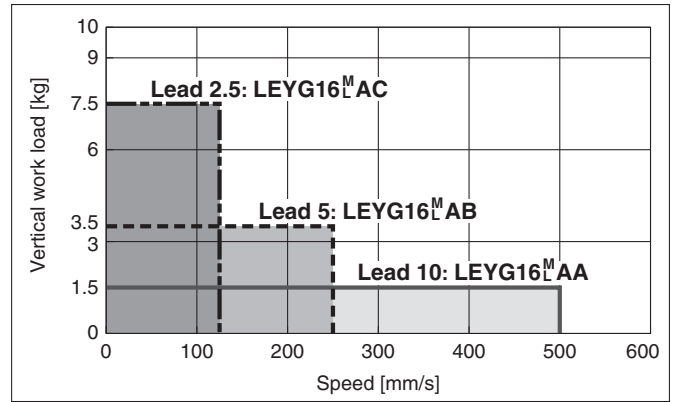

LEYG25^MA□

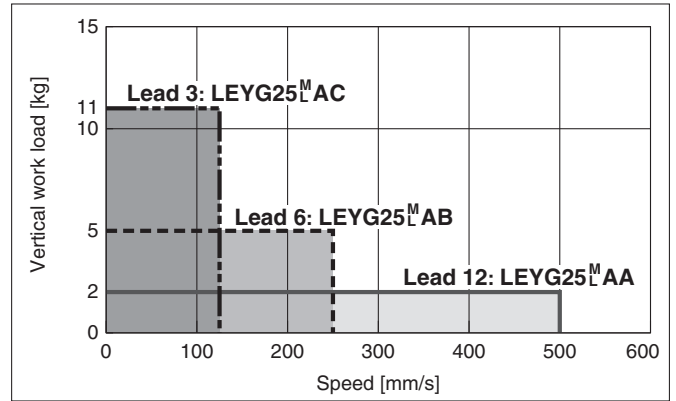

Series LEYG

Step Motor (Servo/24 VDC) Servo Motor (24 VDC)

Force Conversion Graph (Guide)

Step Motor (Servo/24 VDC)

LEYG16^M_L□

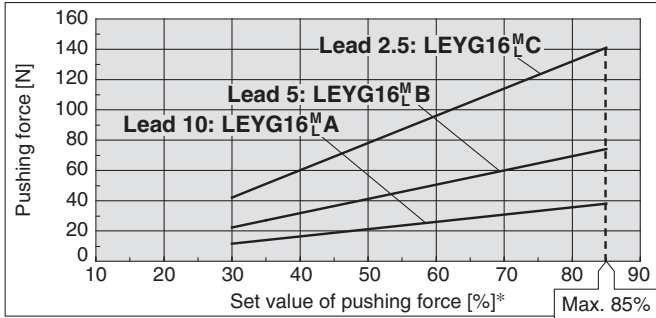

Ambient temperature	Set value of pushing force [%]	Duty ratio [%]	Continuous pushing time [minute]
25 °C or less	85 or less	100	—
	40 or less	100	—
40 °C	50	70	12
	70	20	1.3
	85	15	0.8

LEYG25^M_L□

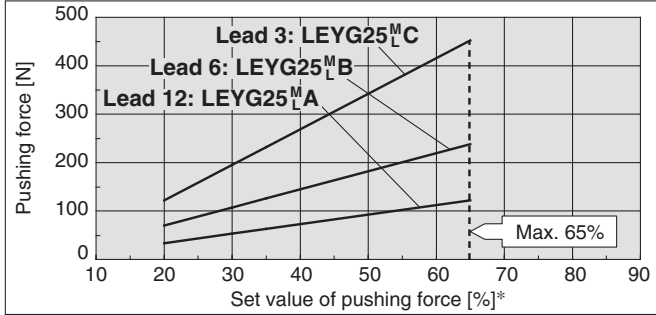

Ambient temperature	Set value of pushing force [%]	Duty ratio [%]	Continuous pushing time [minute]
40 °C or less	65 or less	100	—

LEYG32^M_L□

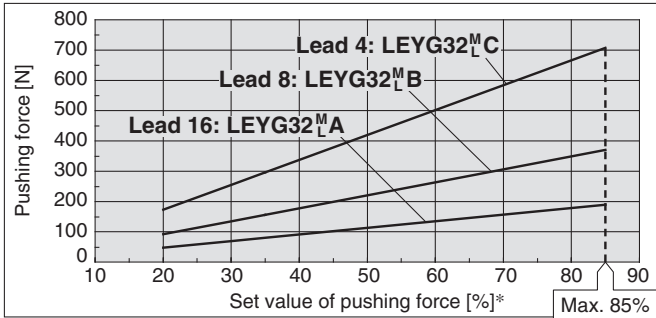

Ambient temperature	Set value of pushing force [%]	Duty ratio [%]	Continuous pushing time [minute]
25 °C or less	85 or less	100	—
	65 or less	100	—
40 °C	85	50	15

LEYG40^M_L□

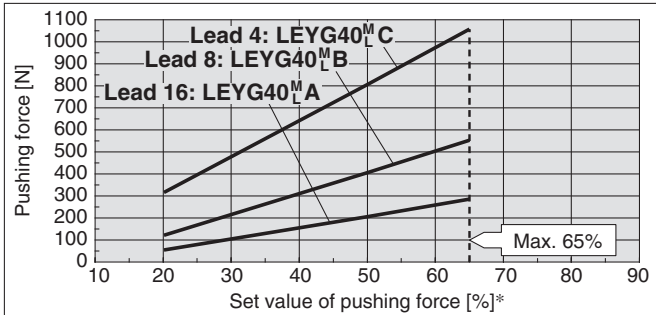

Ambient temperature	Set value of pushing force [%]	Duty ratio [%]	Continuous pushing time [minute]
40 °C or less	65 or less	100	—

* Set values for the controller.

Servo Motor (24 VDC)

LEYG16^M_LA□

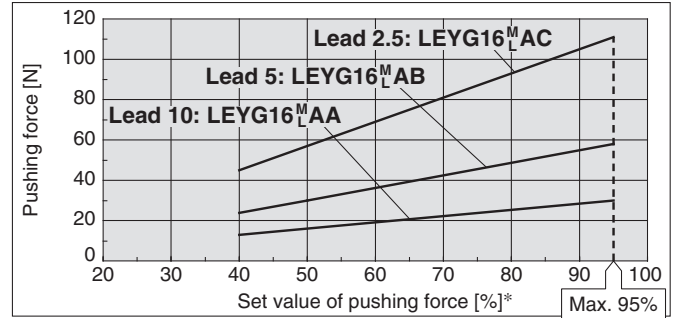

Ambient temperature	Set value of pushing force [%]	Duty ratio [%]	Continuous pushing time [minute]
40 °C or less	95 or less	100	—

LEYG25^M_LA□

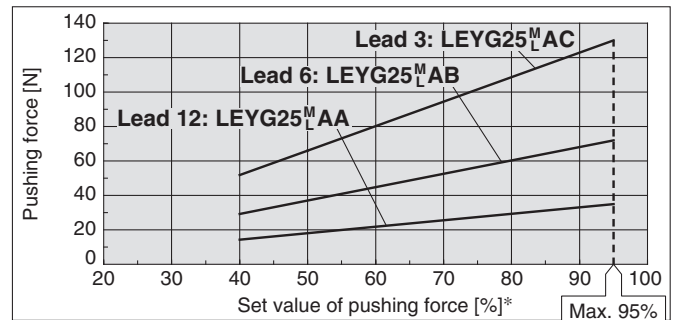

Ambient temperature	Set value of pushing force [%]	Duty ratio [%]	Continuous pushing time [minute]
40 °C or less	95 or less	100	—

<Pushing Force and Trigger Level Range> Without Load

Model	Pushing speed [mm/s]	Pushing force (Setting input value)	Model	Pushing speed [mm/s]	Pushing force (Setting input value)
LEYG16 ^M _L □	1 to 4	30 % to 85 %	LEYG16 ^M _L A□	1 to 4	40 % to 95 %
	5 to 20	35 % to 85 %		5 to 20	60 % to 95 %
	21 to 50	60 % to 85 %		21 to 50	80 % to 95 %
LEYG25 ^M _L □	1 to 4	20 % to 65 %	LEYG25 ^M _L A□	1 to 4	40 % to 95 %
	5 to 20	35 % to 65 %		5 to 20	60 % to 95 %
	21 to 35	50 % to 65 %		21 to 35	80 % to 95 %
LEYG32 ^M _L □	1 to 4	20 % to 85 %	* The pushing force in the table shows the range within which the completion signal [INP] is normally output. If the product is operated outside this range (low pushing force), the [INP] signal may be output when the actuator is moving (before pushing).		
	5 to 20	35 % to 85 %			
	21 to 30	60 % to 85 %			
LEYG40 ^M _L □	1 to 4	20 % to 65 %			
	5 to 20	35 % to 65 %			
	21 to 30	50 % to 65 %			

<Set Values for Vertical Upward Transfer Pushing Operation>

For vertical loads (upward), set the pushing force to the maximum value shown below, and operate at the work load or less.

Model	LEYG16 ^M _L □	LEYG25 ^M _L □	LEYG32 ^M _L □	LEYG40 ^M _L □	LEYG16 ^M _L A□	LEYG25 ^M _L A□						
Lead	A B C	A B C	A B C	A B C	A B C	A B C						
Work load [kg]	0.5 1 2.5	1.5 4 9	2.5 7 16	5 12 26	0.5 1 2.5	0.5 1.5 4						
Pushing force	85 %		65 %		85 %		65 %		95 %		95 %	

Allowable Rotational Torque of Plate

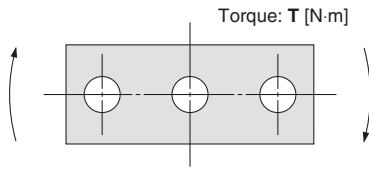

Model	Stroke [mm]					T [N·m]
	30	50	100	200	300	
LEYG16M	0.70	0.57	1.05	0.56	—	
LEYG16L	0.82	1.48	0.97	0.57	—	
LEYG25M	1.56	1.29	3.50	2.18	1.36	
LEYG25L	1.52	3.57	2.47	2.05	1.44	
LEYG32M	2.55	2.09	5.39	3.26	1.88	
LEYG32L	2.80	5.76	4.05	3.23	2.32	
LEYG40M	2.55	2.09	5.39	3.26	1.88	
LEYG40L	2.80	5.76	4.05	3.23	2.32	

Non-rotating Accuracy of Plate

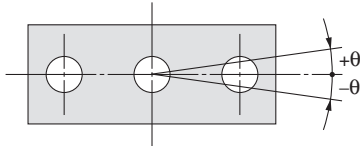

Size	Non-rotating accuracy θ	
	LEYG□M	LEYG□L
16	0.06°	0.05°
25		0.04°
32	0.05°	
40		

Plate Displacement: δ

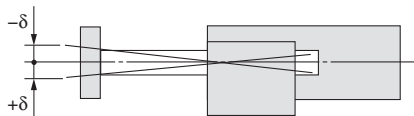

Model	Stroke [mm]					[mm]
	30	50	100	200	300	
LEYG16M	±0.20	±0.25	±0.24	±0.27	—	
LEYG16L	±0.13	±0.12	±0.17	±0.19	—	
LEYG25M	±0.26	±0.31	±0.25	±0.38	±0.36	
LEYG25L	±0.13	±0.13	±0.17	±0.20	±0.23	
LEYG32M	±0.23	±0.29	±0.23	±0.36	±0.34	
LEYG32L	±0.11	±0.11	±0.15	±0.19	±0.22	

Electric Actuator/Guide Rod Type

Step Motor (Servo/24 VDC)

Servo Motor (24 VDC)

Series LEYG

LEYG16, 25, 32, 40



EtherNet/IP IO-Link
 DeviceNet EtherCAT Compatible ▶ Page 99

Multi-Axis Step Motor Controller Compatible ▶ Page 108

How to Order

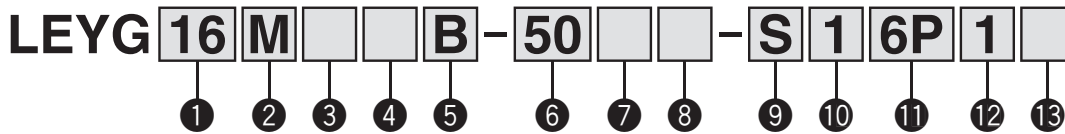

1 Size

16
25
32
40

2 Bearing type

M	Sliding bearing
L	Ball bushing bearing

* When [M: Sliding bearing] is selected, the maximum speed of lead [A] is 400 mm/s (at no-load, horizontal mounting). The speed is also restricted with a horizontal/moment load. Refer to "Model Selection" on page 40.

4 Motor type

Symbol	Type	Size			Compatible controllers/driver
		LEYG16	LEYG25	LEYG32/40	
—	Step motor (Servo/24 VDC)	●	●	●	LECP6 LECP1 LECPA
A	Servo motor (24 VDC)	●	●	—	LECA6

3 Motor mounting position

—	Top mounting
D	In-line

5 Lead [mm]

Symbol	LEYG16	LEYG25	LEYG32/40
A	10	12	16
B	5	6	8
C	2.5	3	4

6 Stroke [mm]

30	30
to	to
300	300

* Refer to the applicable stroke table.

7 Motor option

—	Without option
C	With motor cover
B	With lock
W	With lock and motor cover

* When "With lock" or "With lock/motor cover" are selected for the top mounting type, the motor body will stick out of the end of the body for size 16/40 with stroke 30 mm or less. Check for interference with workpieces before selecting a model.

8 Guide option

—	Without option
F	With grease retaining function

* Only available for size 25, 32 and 40 sliding bearings. (Refer to "Construction" on page 51.)

Caution

[CE-compliant products]

① EMC compliance was tested by combining the electric actuator LEYG series and the controller LEC series. The EMC depends on the configuration of the customer's control panel and the relationship with other electrical equipment and wiring. Therefore conformity to the EMC directive cannot be certified for SMC components incorporated into the customer's equipment under actual operating conditions. As a result it is necessary for the customer to verify conformity to the EMC directive for the machinery and equipment as a whole.

② For the servo motor (24 VDC) specification, EMC compliance was tested by installing a noise filter set (LEC-NFA). Refer to page 73 for the noise filter set. Refer to the LECA Operation Manual for installation.

[UL-compliant products]

When conformity to UL is required, the electric actuator and controller/driver should be used with a UL1310 Class 2 power supply.

For auto switches, refer to pages 27 and 28.

* Applicable stroke table

● Standard

Stroke [mm]	30	50	100	150	200	250	300	Manufacturable stroke range [mm]
Model								
LEYG16	●	●	●	●	●	—	—	10 to 200
LEYG25	●	●	●	●	●	●	●	15 to 300
LEYG32/40	●	●	●	●	●	●	●	20 to 300

* Consult with SMC for non-standard strokes as they are produced as special orders.

The actuator and controller/driver are sold as a package.

Confirm that the combination of the controller/driver and the actuator is correct.

<Check the following before use.>

- Check the actuator label for model number. This matches the controller/driver.
- Check Parallel I/O configuration matches (NPN or PNP).

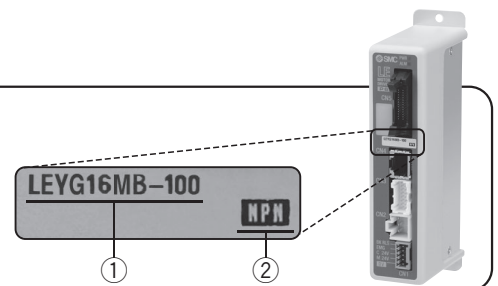

* Refer to the operation manual for using the products. Please download it via our website, <http://www.smcworld.com>

Series LEYG

Step Motor (Servo/24 VDC) Servo Motor (24 VDC)

Specifications

Step Motor (Servo/24 VDC)

Model			LEYG16 ^M _L			LEYG25 ^M _L			LEYG32 ^M _L			LEYG40 ^M _L			
Stroke [mm] ^{Note 1)}			30, 50, 100, 150, 200			30, 50, 100, 150, 200, 250, 300			30, 50, 100, 150, 200, 250, 300			30, 50, 100, 150, 200, 250, 300			
Work load [kg] ^{Note 2)}	Horizontal (LECP6, LECP1, JXC□1)	Acceleration/Deceleration at 3000 [mm/s ²]	6	17	30	20	40	60	30	45	60	50	60	80	
		Acceleration/Deceleration at 2000 [mm/s ²]	10	23	35	30	55	70	40	60	80	60	70	90	
	Horizontal (LECPA, JXC□3)	Acceleration/Deceleration at 3000 [mm/s ²]	4	11	20	12	30	30	20	40	40	30	60	60	
		Acceleration/Deceleration at 2000 [mm/s ²]	6	17	30	18	50	50	30	60	60	—	—	—	
	Vertical	Acceleration/Deceleration at 3000 [mm/s ²]	1.5	3.5	7.5	7	15	29	9	20	41	11	25	51	
Pushing force [N] ^{Note 3) 4) 5)}			14 to 38	27 to 74	51 to 141	63 to 122	126 to 238	232 to 452	80 to 189	156 to 370	296 to 707	132 to 283	266 to 553	562 to 1058	
Speed [mm/s] ^{Note 5)}	LECP6/LECP1		15 to 500	8 to 250	4 to 125	18 to 500	9 to 250	5 to 125	24 to 500	12 to 300	6 to 150	24 to 500	12 to 350	6 to 175	
	LECPA									12 to 250	6 to 125	24 to 300	12 to 150	6 to 75	
Max. acceleration/deceleration [mm/s²]			3000												
Pushing speed [mm/s] ^{Note 6)}			50 or less			35 or less			30 or less			30 or less			
Positioning repeatability [mm]			±0.02												
Lost motion [mm] ^{Note 7)}			0.1 or less												
Screw lead [mm]			10	5	2.5	12	6	3	16	8	4	16	8	4	
Impact/Vibration resistance [m/s²] ^{Note 8)}			50/20												
Actuation type			Ball screw + Belt (LEYG□□□), Ball screw (LEYG□□□D)												
Guide type			Sliding bearing (LEYG□M), Ball bushing bearing (LEYG□L)												
Operating temp. range [°C]			5 to 40												
Operating humidity range [%RH]			90 or less (No condensation)												
Electric specifications	Motor size			□28			□42			□56.4			□56.4		
	Motor type			Step motor (Servo/24 VDC)											
	Encoder			Incremental A/B phase (800 pulse/rotation)											
	Rated voltage [V]			24 VDC ±10 %											
	Power consumption [W] ^{Note 9)}			23			40			50			50		
	Standby power consumption when operating [W] ^{Note 10)}			16			15			48			48		
	Max. instantaneous power consumption [W] ^{Note 11)}			43			48			104			106		
Lock unit specifications	Type ^{Note 12)}			Non-magnetizing lock											
	Holding force [N]			20	39	78	78	157	294	108	216	421	127	265	519
	Power consumption [W] ^{Note 13)}			2.9			5			5			5		
	Rated voltage [V]			24 VDC ±10 %											

Note 1) Please consult with SMC for non-standard strokes as they are produced as special orders.

Note 2) Horizontal: An external guide is necessary to support the load (Friction coefficient of guide: 0.1 or less). The actual work load and transfer speed change according to the condition of the external guide. Also, speed changes according to the work load. Check "Model Selection" on pages 42 and 43.

Vertical: Speed changes according to the work load. Check "Model Selection" on pages 42 and 43.

Set the acceleration/deceleration values to be 3000 [mm/s²] or less.

Note 3) Pushing force accuracy is ±20 % (F.S.).

Note 4) The pushing force values for LEYG16□□ is 35 % to 85 %, for LEYG25□□ is 35 % to 65 %, for LEYG32□□ is 35 % to 85 % and for LEYG40□□ is 35 % to 65 %. The pushing force values change according to the duty ratio and pushing speed. Check "Model Selection" on page 45.

Note 5) The speed and force may change depending on the cable length, load and mounting conditions. Furthermore, if the cable length exceeds 5 m, then it will decrease by up to 10 % for each 5 m. (At 15 m: Reduced by up to 20 %)

When [M: Sliding bearing] is selected, the maximum speed of lead [A] is 400 mm/s (at no-load, horizontal mounting).

The speed is also restricted with a horizontal/moment load. Refer to "Model Selection" on page 40.

Note 6) The allowable speed for the pushing operation.

Note 7) A reference value for correcting an error in reciprocal operation.

Note 8) Impact resistance: No malfunction occurred when it was tested with a drop tester in both an axial direction and a perpendicular direction to the lead screw. (Test was performed with the actuator in the initial state.)

Vibration resistance: No malfunction occurred in a test ranging between 45 to 2000 Hz. Test was performed in both an axial direction and a perpendicular direction to the lead screw. (Test was performed with the actuator in the initial state.)

Note 9) The power consumption (including the controller) is for when the actuator is operating.

Note 10) The standby power consumption when operating (including the controller) is for when the actuator is stopped in the set position during the operation. Except during the pushing operation.

Note 11) The maximum instantaneous power consumption (including the controller) is for when the actuator is operating. This value can be used for the selection of the power supply.

Note 12) With lock only

Note 13) For an actuator with lock, add the power consumption for the lock.

Specifications

Servo Motor (24 VDC)

Model			LEYG16 ^M A			LEYG25 ^M A		
Stroke [mm] <small>Note 1)</small>			30, 50, 100, 150, 200			30, 50, 100, 150, 200, 250, 300		
Work load [kg] <small>Note 2)</small>	Horizontal	Acceleration/Deceleration at 3000 [mm/s ²]	3	6	12	7	15	30
	Vertical	Acceleration/Deceleration at 3000 [mm/s ²]	1.5	3.5	7.5	2	5	11
Pushing force [N] <small>Note 3) 4)</small>			16 to 30	30 to 58	57 to 111	18 to 35	37 to 72	66 to 130
Speed [mm/s]			15 to 500	8 to 250	4 to 125	18 to 500	9 to 250	5 to 125
Max. acceleration/deceleration [mm/s²]			3000					
Pushing speed [mm/s] <small>Note 5)</small>			50 or less			35 or less		
Positioning repeatability [mm]			±0.02					
Lost motion [mm] <small>Note 6)</small>			0.1 or less					
Screw lead [mm]			10	5	2.5	12	6	3
Impact/Vibration resistance [m/s²] <small>Note 7)</small>			50/20					
Actuation type			Ball screw + Belt (LEYG□□□), Ball screw (LEYG□□□D)					
Guide type			Sliding bearing (LEYG□□M), Ball bushing bearing (LEYG□□L)					
Operating temp. range [°C]			5 to 40					
Operating humidity range [%RH]			90 or less (No condensation)					
Motor size			□28			□42		
Motor output [W]			30			36		
Motor type			Servo motor (24 VDC)					
Encoder			Incremental A/B (800 pulse/rotation)/Z phase					
Rated voltage [V]			24 VDC ±10 %					
Power consumption [W] <small>Note 8)</small>			40			86		
Standby power consumption when operating [W] <small>Note 9)</small>			4 (Horizontal)/6 (Vertical)			4 (Horizontal)/12 (Vertical)		
Max. instantaneous power consumption [W] <small>Note 10)</small>			59			96		
Type <small>Note 11)</small>			Non-magnetizing lock					
Holding force [N]			20	39	78	78	157	294
Power consumption [W] <small>Note 12)</small>			2.9			5		
Rated voltage [V]			24 VDC ±10 %					

Note 1) Consult with SMC for non-standard strokes as they are produced as special orders.

Note 2) Horizontal: The maximum value of the work load for the positioning operation. The work load is the same as the vertical work load during pushing operation. An external guide is necessary to support the load. The actual work load and transfer speed change according to the condition of the external guide.
Vertical: Check "Model Selection" on page 44 for details. Set the acceleration/deceleration values to be 3000 [mm/s²] or less.

Note 3) Pushing force accuracy is ±20 % (F.S.).
Note 4) The pushing force values for LEYG16□A□ is 50 % to 95 % and for LEYG25□A□ is 50 % to 95 %. The pushing force values change according to the duty ratio and pushing speed. Check "Model Selection" on page 45.

Note 5) The allowable speed for the pushing operation.
Note 6) A reference value for correcting an error in reciprocal operation.

Note 7) Impact resistance: No malfunction occurred when it was tested with a drop tester in both an axial direction and a perpendicular direction to the lead screw. (Test was performed with the actuator in the initial state.)
Vibration resistance: No malfunction occurred in a test ranging between 45 to 2000 Hz. Test was performed in both an axial direction and a perpendicular direction to the lead screw. (Test was performed with the actuator in the initial state.)

Note 8) The power consumption (including the controller) is for when the actuator is operating.
Note 9) The standby power consumption when operating (including the controller) is for when the actuator is stopped in the set position during the operation. Except during the pushing operation.

Note 10) The maximum instantaneous power consumption (including the controller) is for when the actuator is operating. This value can be used for the selection of the power supply.
Note 11) With lock only

Note 12) For an actuator with lock, add the power consumption for the lock.

Weight

Weight: Motor Top Mounting Type

Model		LEYG16M					LEYG25M					LEYG32M								
Stroke [mm]		30	50	100	150	200	30	50	100	150	200	250	300	30	50	100	150	200	250	300
Product weight [kg]	Step motor	0.83	0.97	1.20	1.49	1.66	1.67	1.86	2.18	2.60	2.94	3.28	3.54	2.91	3.17	3.72	4.28	4.95	5.44	5.88
	Servo motor	0.83	0.97	1.20	1.49	1.66	1.63	1.82	2.14	2.56	2.90	3.24	3.50	—	—	—	—	—	—	—

Model		LEYG16L					LEYG25L					LEYG32L								
Stroke [mm]		30	50	100	150	200	30	50	100	150	200	250	300	30	50	100	150	200	250	300
Product weight [kg]	Step motor	0.84	0.97	1.14	1.43	1.58	1.68	1.89	2.13	2.56	2.82	3.14	3.38	2.91	3.18	3.57	4.12	4.66	5.17	5.56
	Servo motor	0.84	0.97	1.14	1.43	1.58	1.64	1.85	2.09	2.52	2.78	3.10	3.34	—	—	—	—	—	—	—

Model		LEYG40M					LEYG40L								
Stroke [mm]		30	50	100	150	200	250	300	30	50	100	150	200	250	300
Product weight [kg]	Step motor	3.21	3.47	4.02	4.58	5.25	5.74	6.18	3.21	3.48	3.87	4.42	4.96	5.47	5.86
	Servo motor	—	—	—	—	—	—	—	—	—	—	—	—	—	—

Weight: In-line Motor Type

Model		LEYG16M					LEYG25M					LEYG32M								
Stroke [mm]		30	50	100	150	200	30	50	100	150	200	250	300	30	50	100	150	200	250	300
Product weight [kg]	Step motor	0.83	0.97	1.20	1.49	1.66	1.66	1.85	2.17	2.59	2.93	3.27	3.53	2.90	3.16	3.71	4.27	4.94	5.43	5.87
	Servo motor	0.83	0.97	1.20	1.49	1.66	1.62	1.81	2.13	2.55	2.89	3.23	3.49	—	—	—	—	—	—	—

Model		LEYG16L					LEYG25L					LEYG32L								
Stroke [mm]		30	50	100	150	200	30	50	100	150	200	250	300	30	50	100	150	200	250	300
Product weight [kg]	Step motor	0.84	0.97	1.14	1.43	1.58	1.67	1.88	2.12	2.55	2.81	3.13	3.37	2.90	3.17	3.56	4.11	4.65	5.16	5.55
	Servo motor	0.84	0.97	1.14	1.43	1.58	1.63	1.84	2.08	2.51	2.77	3.09	3.33	—	—	—	—	—	—	—

Model		LEYG40M					LEYG40L								
Stroke [mm]		30	50	100	150	200	250	300	30	50	100	150	200	250	300
Product weight [kg]	Step motor	3.20	3.46	4.01	4.57	5.24	5.73	6.17	3.20	3.47	3.86	4.41	4.95	5.46	5.85
	Servo motor	—	—	—	—	—	—	—	—	—	—	—	—	—	—

Additional Weight

Size	16	25	32	40
Lock	0.12	0.26	0.53	0.53
Motor cover	0.02	0.03	0.04	0.05
Lock/Motor cover	0.16	0.32	0.61	0.62

Model Selection

LEY

LEYG

LECA6

LECP6

LEC-G

LECP1

LECPA

JXC□1

JXC7303/92/93

LEY

LEYG

AC Servo Motor

LECS□

LECS-T

LECY□

Specific Product Precautions

Series LEYG

Step Motor (Servo/24 VDC) Servo Motor (24 VDC)

Construction

Motor top mounting type

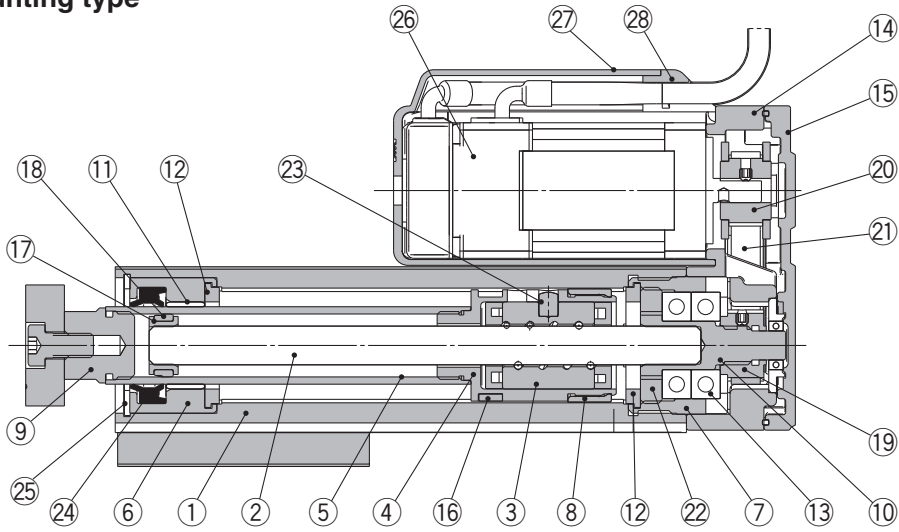

Motor top mounting type With lock/motor cover

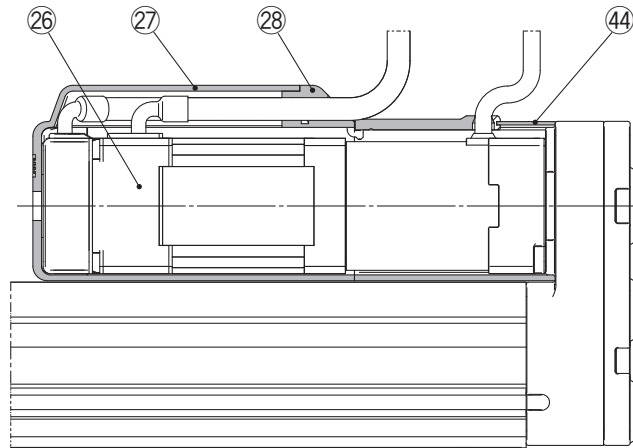

In-line motor type

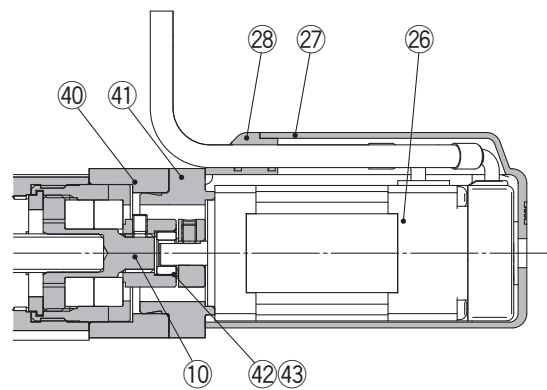

In-line motor type With lock/motor cover

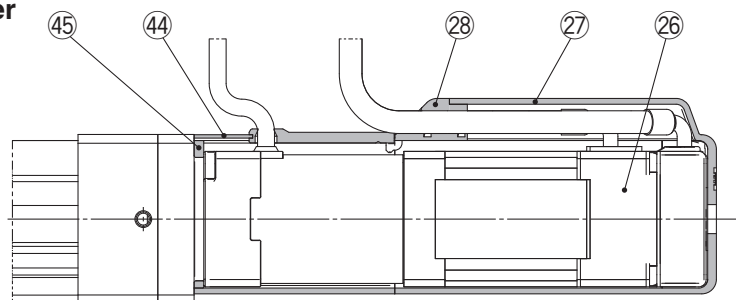

Electric Actuator/Guide Rod Type **Series LEYG**

Step Motor (Servo/24 VDC) Servo Motor (24 VDC)

Construction

LEYG□M

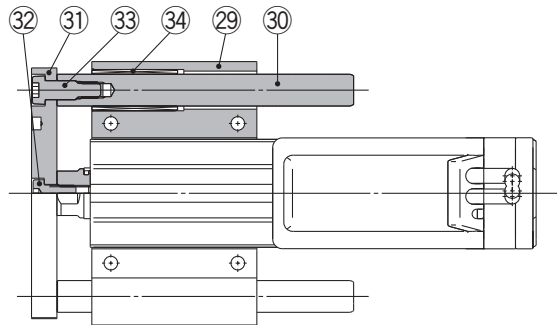

LEYG¹⁶₂₅³²₄₀M: 50st or less



LEYG¹⁶₂₅³²₄₀M: Over 50st



When grease retaining function selected

LEYG²⁵₃₂⁴⁰M□□^A_B-□□F: 50st or less

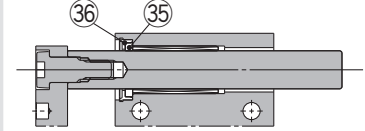

LEYG²⁵₃₂⁴⁰M□□^A_B-□□F: Over 50st



Note) Felt material is inserted to retain grease at the sliding part of the sliding bearing. This lengthens the life of the sliding part, but does not guarantee it permanently.

LEYG□L

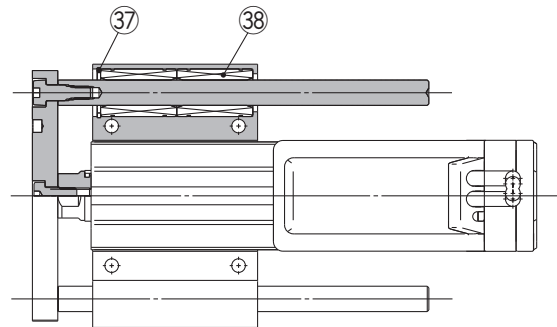

LEYG16L: 30st or less

LEYG²⁵₃₂⁴⁰L: 100st or less

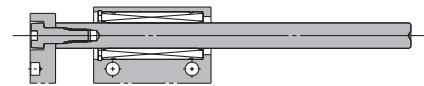

LEYG16L: Over 30st, 100st or less

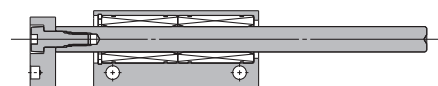

LEYG¹⁶₂₅³²₄₀L: Over 100st

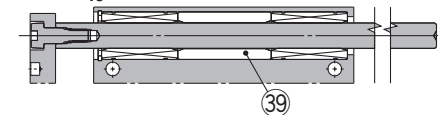

Component Parts

No.	Description	Material	Note
1	Body	Aluminium alloy	Anodised
2	Ball screw (shaft)	Alloy steel	
3	Ball screw nut	Resin/Alloy steel	
4	Piston	Aluminium alloy	
5	Piston rod	Stainless steel	Hard chrome plating
6	Rod cover	Aluminium alloy	
7	Housing	Aluminium alloy	
8	Rotation stopper	POM	
9	Socket	Free cutting carbon steel	Nickel plating
10	Connected shaft	Free cutting carbon steel	Nickel plating
11	Bushing	Lead bronze cast	
12	Bumper	Urethane	
13	Bearing	—	
14	Return box	Aluminium die-cast	Coating
15	Return plate	Aluminium die-cast	Coating
16	Magnet	—	
17	Wear ring holder	Stainless steel	Stroke 101 mm or more
18	Wear ring	POM	Stroke 101 mm or more
19	Screw shaft pulley	Aluminium alloy	
20	Motor pulley	Aluminium alloy	
21	Belt	—	
22	Bearing stopper	Aluminium alloy	
23	Parallel pin	Stainless steel	
24	Seal	NBR	
25	Retaining ring	Steel for spring	Phosphate coated
26	Motor	—	
27	Motor cover	Synthetic resin	Only "With motor cover"
28	Grommet	Synthetic resin	Only "With motor cover"

No.	Description	Material	Note
29	Guide attachment	Aluminium alloy	Anodised
30	Guide rod	Carbon steel	
31	Plate	Aluminium alloy	Anodised
32	Plate mounting cap screw	Carbon steel	Nickel plating
33	Guide cap screw	Carbon steel	Nickel plating
34	Sliding bearing	—	
35	Lube-retainer	Felt	
36	Holder	Resin	
37	Retaining ring	Steel for spring	Phosphate coated
38	Ball bushing	—	
39	Spacer	Aluminium alloy	Chromated
40	Motor block	Aluminium alloy	Anodised
41	Motor adapter	Aluminium alloy	Anodised/LEY16, 25 only
42	Hub	Aluminium alloy	
43	Spider	NBR	
44	Motor cover with lock	Aluminium alloy	Only "With lock/motor cover"
45	Cover support	Aluminium alloy	Only "With lock/motor cover"

Replacement Parts/Belt

No.	Size	Order no.
21	16	LE-D-2-1
	25	LE-D-2-2
	32, 40	LE-D-2-3

Replacement Parts/Grease Pack

Applied portion	Order no.
Piston rod	GR-S-010 (10 g)
Guide rod	GR-S-020 (20 g)

* Apply grease on the piston rod periodically. Grease should be applied at 1 million cycles or 200 km, whichever comes first.

Model Selection

LEY

LEYG

LECA6
LECP6

LEC-G

LECP1

LECPA

JXC□1

JXC7□□□□□□

LEY

LEYG

LECS□

LECS-T

LECY□

Specific Product Precautions

Series LEYG

Step Motor (Servo/24 VDC) Servo Motor (24 VDC)

Dimensions: Motor Top Mounting

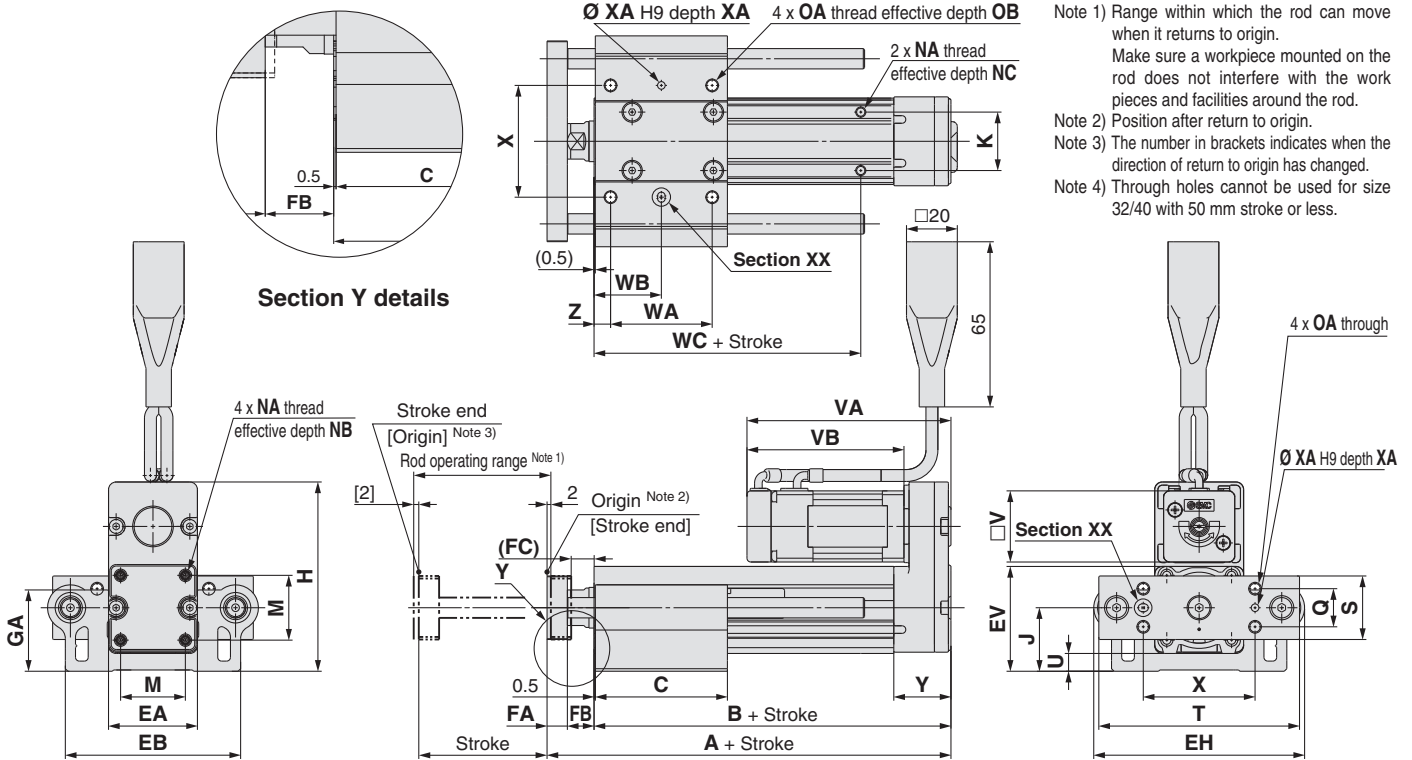

- Note 1) Range within which the rod can move when it returns to origin. Make sure a workpiece mounted on the rod does not interfere with the work pieces and facilities around the rod.
- Note 2) Position after return to origin.
- Note 3) The number in brackets indicates when the direction of return to origin has changed.
- Note 4) Through holes cannot be used for size 32/40 with 50 mm stroke or less.

LEYG□L (Ball bushing bearing) Standard stroke: 50, 100, 200

Size	Stroke range	L	DB
16	90st or less	75	8
	91st or more, 200st or less	105	
	114st or less	91	
25	115st or more, 190st or less	115	10
	191st or more, 300st or less	133	
	114st or less	97.5	
32	115st or more, 190st or less	116.5	13
	191st or more, 300st or less	134	

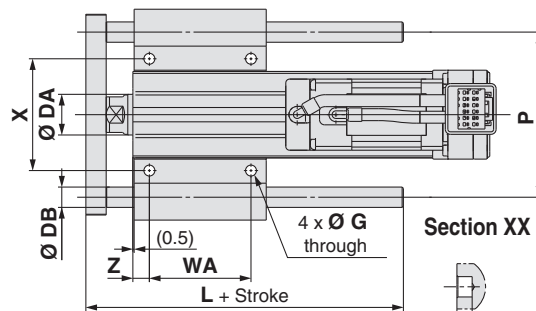

LEYG□M (Sliding bearing) Standard stroke: 30, 50, 100

Size	Stroke range	L	DB
16	64st or less	51.5	10
	65st or more, 90st or less	74.5	
	91st or more, 200st or less	105	
25	59st or less	67.5	12
	60st or more, 185st or less	100.5	
	186st or more, 300st or less	138	
32	54st or less	74	16
	55st or more, 180st or less	107	
	181st or more, 300st or less	144	

LEYG□M, LEYG□L Common

Size	Stroke range	A	B	C	DA	EA	EB	EH	EV	FA	FB	FC	G	GA	H	J	K	M	NA	NB	NC
16	39st or less	109	90.5	37	16	35	69	83	41.3	8	10.5	8.5	4.3	32	74.3	24.3	23	25.5	M4 x 0.7	7	5.5
	40st or more, 100st or less			52																	
	101st or more, 200st or less			82																	
25	39st or less	141.5	116	50	20	46	85	103	52.5	11	14.5	12.5	5.4	40.5	98.8	30.8	29	34	M5 x 0.8	8	6.5
	40st or more, 100st or less			67.5																	
	101st or more, 124st or less			84.5																	
	125st or more, 200st or less			102																	
	201st or more, 300st or less			102																	
32	39st or less	160.5	130	55	25	60	101	123	64	12	18.5	16.5	5.4	50.5	125.3	38.3	30	40	M6 x 1.0	10	8.5
	40st or more, 100st or less			68																	
	101st or more, 124st or less			85																	
	125st or more, 200st or less			85																	
	201st or more, 300st or less			102																	
40	39st or less	160.5	130	55	25	60	101	123	64	12	18.5	16.5	5.4	50.5	125.3	38.3	30	40	M6 x 1.0	10	8.5
	40st or more, 100st or less			68																	
	101st or more, 124st or less			85																	
	125st or more, 200st or less			85																	
	201st or more, 300st or less			102																	

Size	Stroke range	OA	OB	P	Q	S	T	U	V	Step motor VA	Step motor VB	Servo motor VA	Servo motor VB	WA	WB	WC	X	XA	XB	Y	Z
16	39st or less	M5 x 0.8	10	65	15	25	79	6.8	28	80.3	61.8	81	62.5	25	19	55	44	3	4	22.5	6.5
	40st or more, 100st or less													40	26.5						
	101st or more, 200st or less													70	41.5						
25	39st or less	M6 x 1.0	12	80	18	30	95	6.8	42	85.4	63.4	81.6	59.6	35	26	70	54	4	5	26.5	8.5
	40st or more, 100st or less													50	33.5						
	101st or more, 124st or less													70	43.5						
	125st or more, 200st or less													85	51						
	201st or more, 300st or less													85	51						
32	39st or less	M6 x 1.0	12	95	28	40	117	7.3	56.4	95.4	68.4	—	—	40	28.5	75	64	5	6	34	8.5
	40st or more, 100st or less													50	33.5						
	101st or more, 124st or less													70	43.5						
	125st or more, 200st or less													85	51						
	201st or more, 300st or less													85	51						
40	39st or less	M6 x 1.0	12	95	28	40	117	7.3	56.4	117.4	90.4	—	—	40	28.5	75	64	5	6	34	8.5
	40st or more, 100st or less													50	33.5						
	101st or more, 124st or less													70	43.5						
	125st or more, 200st or less													85	51						
	201st or more, 300st or less													85	51						

Dimensions: In-line Motor

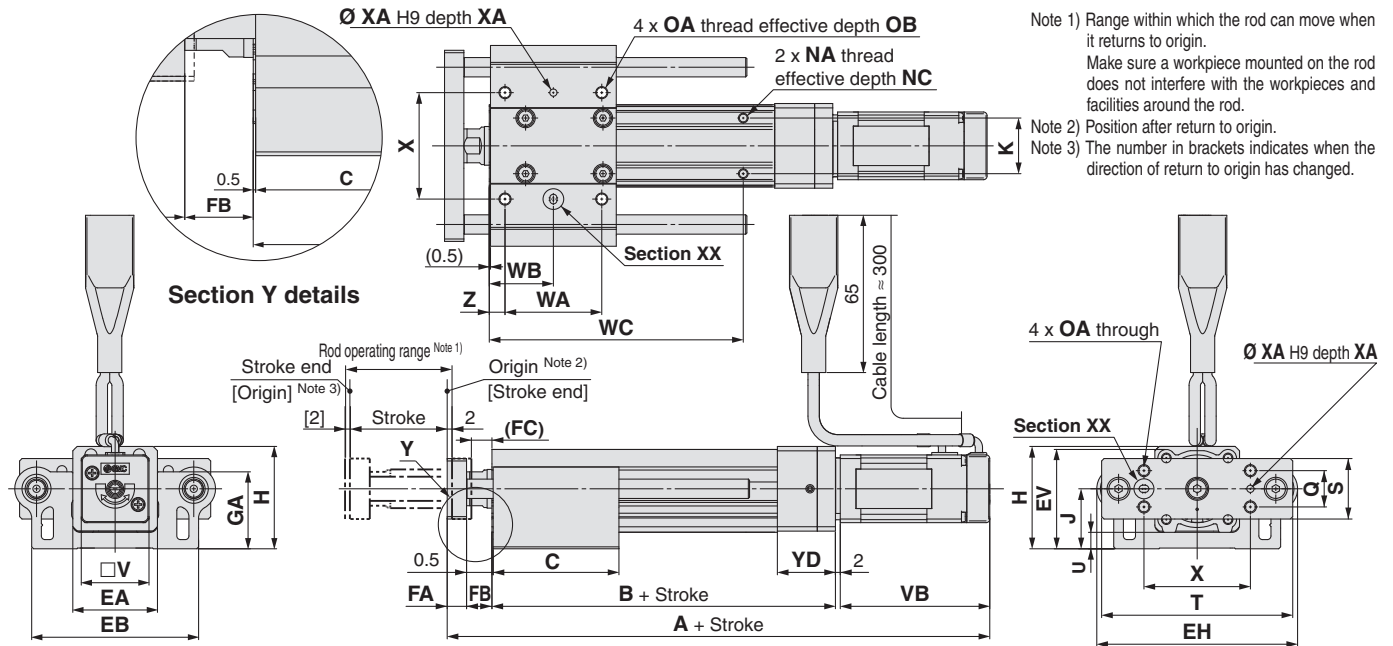

LEYG□L (Ball bushing bearing) Standard stroke: 50, 100, 200

Size	Stroke range	L	DB
16	90st or less	75	8
	91st or more, 200st or less	105	
25	114st or less	91	10
	115st or more, 190st or less	115	
	191st or more, 300st or less	133	
32	114st or less	97.5	13
40	115st or more, 190st or less	116.5	
	191st or more, 300st or less	134	

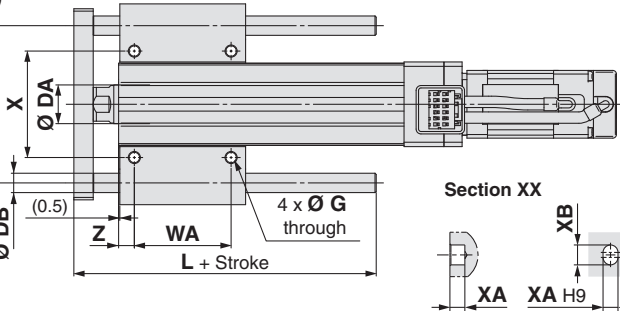

LEYG□M (Sliding bearing) Standard stroke: 30, 50, 100

Size	Stroke range	L	DB
16	64st or less	51.5	10
	65st or more, 90st or less	74.5	
	91st or more, 200st or less	105	
25	59st or less	67.5	12
	60st or more, 185st or less	100.5	
	186st or more, 300st or less	138	
32	54st or less	74	16
	55st or more, 180st or less	107	
40	181st or more, 300st or less	144	

LEYG□M, LEYG□L Common

Size	Stroke range	Step motor		Servo motor		B	C	DA	EA	EB	EH	EV	FA	FB	FC	G	GA	H	J	K	NA	NC
		A	A	A	A																	
16	39st or less	174.3	175	92	37	16	35	69	83	41.3	8	10.5	8.5	4.3	32	42.3	24.8	23	M4 x 0.7	5.5		
	40st or more, 100st or less	194.3	195	112	52																	
	101st or more, 200st or less	194.3	195	112	82																	
25	39st or less	206.4	202.6	115.5	50	20	45	85	103	52.5	11	14.5	12.5	5.4	40.5	53.3	38.8	29	M5 x 0.8	6.5		
	40st or more, 100st or less	231.4	227.6	140.5	67.5																	
	101st or more, 124st or less				84.5																	
	125st or more, 200st or less				102																	
	201st or more, 300st or less				102																	
32	39st or less	228.9	—	128	55	25	60	101	123	64	12	18.5	16.5	5.4	50.5	68.3	38.3	30	M6 x 1.0	8.5		
	40st or more, 100st or less	258.9	—	158	68																	
	101st or more, 124st or less				85																	
	125st or more, 200st or less				102																	
	201st or more, 300st or less				102																	
40	39st or less	250.9	—	128	55	25	60	101	123	64	12	18.5	16.5	5.4	50.5	68.3	38.3	30	M6 x 1.0	8.5		
	40st or more, 100st or less	280.9	—	158	68																	
	101st or more, 124st or less				85																	
	125st or more, 200st or less				102																	
	201st or more, 300st or less				102																	

Size	Stroke range	OA	OB	P	Q	S	T	U	V	Step motor		WA	WB	WC	X	XA	XB	YD	Z
										VB	VB								
16	39st or less	M5 x 0.8	10	65	15	25	79	6.8	28	61.8	62.5	25	19	55	44	3	4	24	6.5
	40st or more, 100st or less											40	26.5						
	101st or more, 200st or less											70	41.5						
25	39st or less	M6 x 1.0	12	80	18	30	95	6.8	42	63.4	59.6	35	26	70	54	4	5	26	8.5
	40st or more, 100st or less											50	33.5						
	101st or more, 124st or less											70	43.5						
	125st or more, 200st or less											85	51						
	201st or more, 300st or less											85	51						
32	39st or less	M6 x 1.0	12	95	28	40	117	7.3	56.4	68.4	—	40	28.5	75	64	5	6	32	8.5
	40st or more, 100st or less											50	33.5						
	101st or more, 124st or less											70	43.5						
	125st or more, 200st or less											85	51						
	201st or more, 300st or less											85	51						
40	39st or less	M6 x 1.0	12	95	28	40	117	7.5	56.4	90.4	—	40	28.5	75	64	5	6	32	8.5
	40st or more, 100st or less											50	33.5						
	101st or more, 124st or less											70	43.5						
	125st or more, 200st or less											85	51						
	201st or more, 300st or less											85	51						

Model Selection

LEY

LEYG

Servo Motor (24 VDC)/Step Motor (Servo/24 VDC)

LECA6

LECP6

LEC-G

LECP1

LECPA

JXC□1

JXC7303/92/93

AC Servo Motor

LEY

LEYG

LECS□

LECS-T

LECY□

Specific Product Precautions

Series LEYG

Step Motor (Servo/24 VDC) Servo Motor (24 VDC)

Dimensions

Motor top mounting type

With motor cover: LEYG $\begin{matrix} 16 \\ 25 \\ 32 \\ 40 \end{matrix} \square \square \square \begin{matrix} A \\ B \\ C \end{matrix} \square \square \square C$

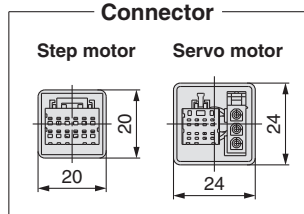

Size	T ₂	X ₂
16	7.5	83
25	7.5	88.5
32	7.5	98.5
40	7.5	120.5

Motor cover material:
Synthetic resin

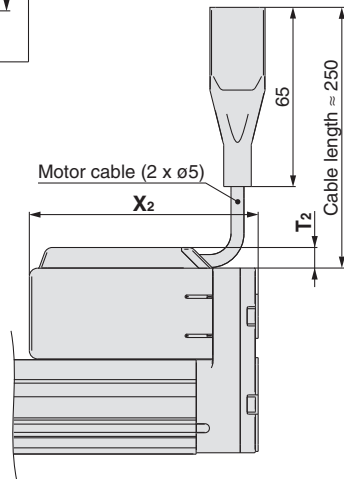

With lock: LEYG $\begin{matrix} 16 \\ 25 \\ 32 \\ 40 \end{matrix} \square \square \square \begin{matrix} A \\ B \\ C \end{matrix} \square \square B$

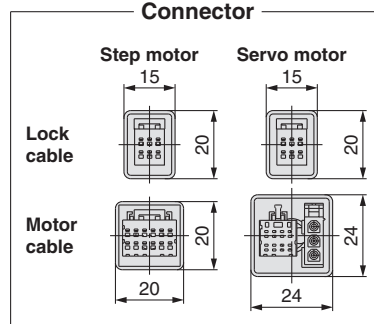

Size	Step motor		Servo motor	
	W	X	W	X
16	103.3	121.8	104.0	122.5
25	103.9	125.9	100.1	122.1
32	111.4	138.4	—	—
40	133.4	160.4	—	—

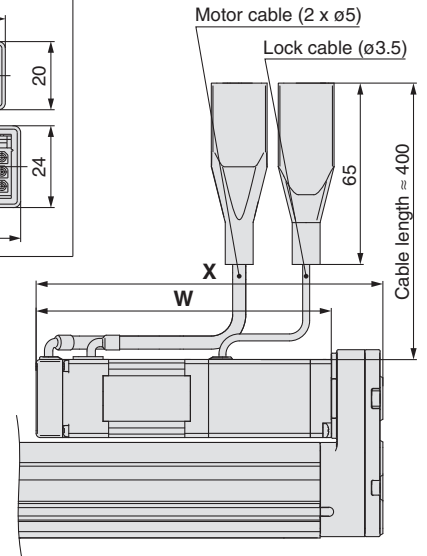

In-line motor type

With motor cover: LEYG $\begin{matrix} 16 \\ 25 \\ 32 \\ 40 \end{matrix} \square \square \square \begin{matrix} A \\ B \\ C \end{matrix} \square \square \square C$

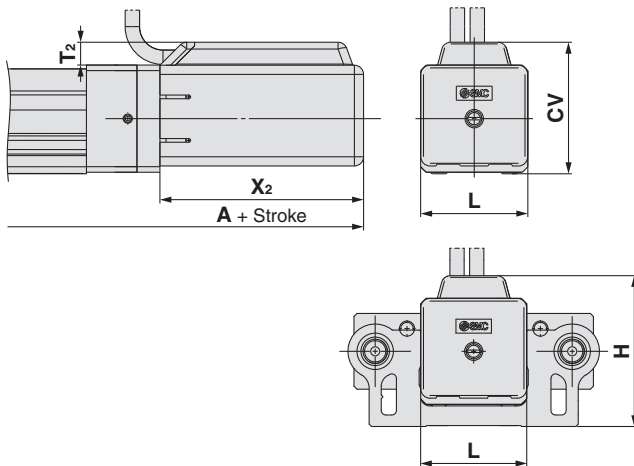

Size	Stroke range	A	T ₂	X ₂	L	H	CV
16	100st or less	177	7.5	66.5	35	49.8	43
	101st or more, 200st or less	197					
25	100st or less	209.5	7.5	68.5	46	61.3	54.5
	101st or more, 300st or less	234.5					
32	100st or less	232	7.5	73.5	60	75.8	68.5
	101st or more, 300st or less	262					
40	100st or less	254	7.5	95.5	60	75.8	68.5
	101st or more, 300st or less	284					

With lock: LEYG $\begin{matrix} 16 \\ 25 \\ 32 \\ 40 \end{matrix} \square \square \square \begin{matrix} A \\ B \\ C \end{matrix} \square \square \square B$

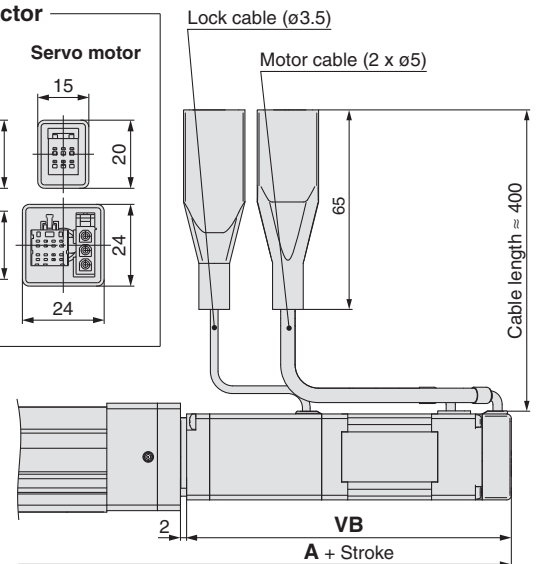
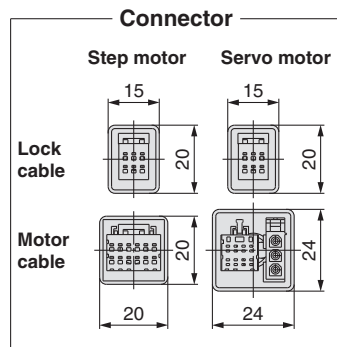

Size	Stroke range	Step motor		Servo motor	
		A	VB	Step motor	Servo motor
16	100st or less	215.8	216.5	103.3	104
	101st or more, 200st or less	235.8	236.5		
25	100st or less	246.9	243.1	103.9	100.1
	101st or more, 300st or less	271.9	268.1		
32	100st or less	271.9	—	111.4	—
	101st or more, 300st or less	301.9	—		
40	100st or less	293.9	—	133.4	—
	101st or more, 300st or less	323.9	—		

Electric Actuator/Guide Rod Type **Series LEYG**

Step Motor (Servo/24 VDC) Servo Motor (24 VDC)

Dimensions

Motor top mounting type
 With lock/motor cover: LEYG $\begin{matrix} 16 \\ 25 \\ 32 \\ 40 \end{matrix} \square \square \begin{matrix} A \\ B \\ C \end{matrix} \square W$

In-line motor type
 With lock/motor cover: LEYG $\begin{matrix} 16 \\ 25 \\ 32 \\ 40 \end{matrix} D \square \begin{matrix} A \\ B \\ C \end{matrix} \square W$

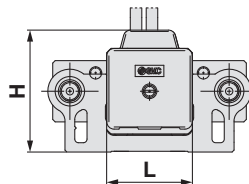
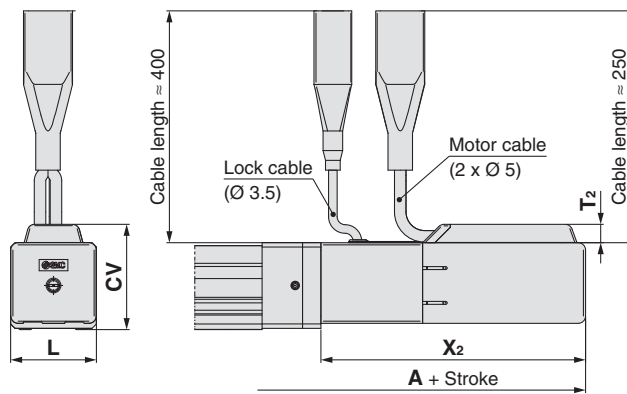
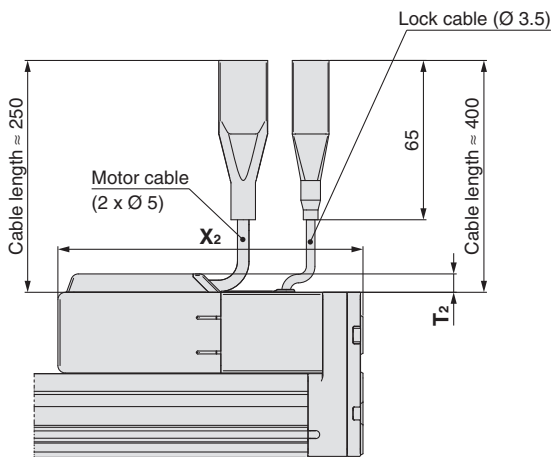

[mm]		
Size	T ₂	X ₂
16	7.5	124.5
25	7.5	129
32	7.5	141.5
40	7.5	163.5

[mm]							
Size	Stroke range	A	T ₂	X ₂	L	H	CV
16	100st or less	218.5	7.5	108	35	49.8	43
	101st or more, 300st or less	238.5					
25	100st or less	250	7.5	109	46	61.3	54.4
	101st or more, 300st or less	275					
32	100st or less	275	7.5	116.5	60	75.8	68.5
	101st or more, 300st or less	305					
40	100st or less	297	7.5	138.5	60	75.8	68.5
	101st or more, 300st or less	327					

Model Selection

Servo Motor (24 VDC)/Step Motor (Servo/24 VDC)
 LEY
 LEYG

LECA6
 LECP6

LEC-G

LECP1

LECPA

JXC1

JXC7/3/3/3/2/3/3

AC Servo Motor
 LEY
 LEYG

LECS

LECS-T

LECY

Specific Product Precautions

Series LEYG

Step Motor (Servo/24 VDC) Servo Motor (24 VDC)

Support Block

● Guide for support block application

When the stroke exceeds 100 mm and the mounting orientation is horizontal, the body will be bent. Mounting the support block is recommended. (Please order it separately from the models shown below.)

Support Block Model

LEYG-S 016

● Size

016	For size 16
025	For size 25
032	For size 32, 40

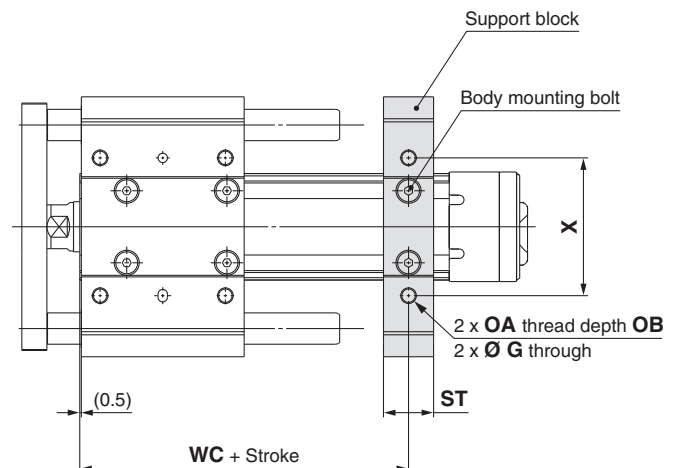
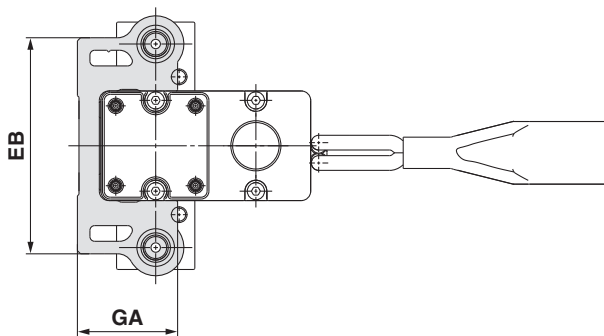
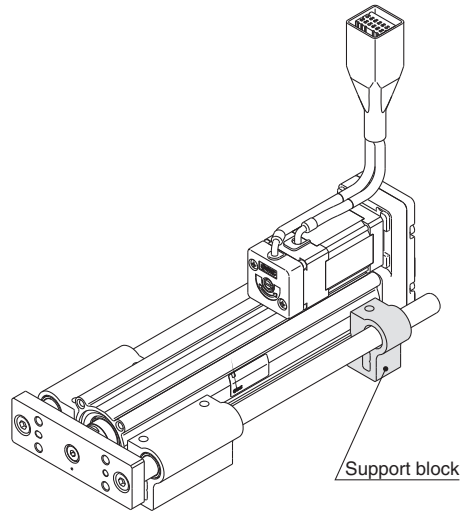

⚠ Caution

Do not install the body using only a support block.
The support block should be used only for support.

Size	Model	Stroke range	EB	G	GA	OA	OB	ST	WC	X
16	LEYG-S016	100st or less	69	4.3	31.8	M5 x 0.8	10	16	55	44
		101st or more, 200st or less							75	
25	LEYG-S025	100st or less	85	5.4	40.3	M6 x 1.0	12	20	70	54
		101st or more, 300st or less							95	
32 40	LEYG-S032	100st or less	101	5.4	50.3	M6 x 1.0	12	22	75	64
		101st or more, 300st or less							105	

* Two body mounting screws are included with the support block.

* The through holes of the LEYG-S032 cannot be used. Use taps on the bottom.

Specific Product Precautions	LECY □	LECSS-T	LECS □	AC Servo Motor		JXC7303/02/03	JXC □1	LECPA	LECP1	LEC-G	LECA6 LECP6	Servo Motor (24 VDC)/Step Motor (Servo/24 VDC)		Model Selection
				LEYG	LEY							LEYG	LEY	



Series LEY/LEYG Electric Actuators/ Specific Product Precautions 1

Be sure to read before handling. Refer to back cover for Safety Instructions and the Operation Manual for Electric Actuator Precautions.
Please download it via our website, <http://www.smc.eu>

Design/Selection

Warning

1. Do not apply a load in excess of the operating limit.

Select a suitable actuator by load and allowable lateral load on the rod end. If the product is used outside of the operating limit, the eccentric load applied to the piston rod will be excessive and have adverse effects such as creating play on the sliding parts of the piston rod, degrading accuracy and shortening the life of the product.

2. Do not use the product in applications where excessive external force or impact force is applied to it.

This can cause failure.

3. When used as a stopper, select the LEYG series "Sliding bearing" for a stroke of 30 mm or less.

4. When used as a stopper, fix the main body with a guide attachment ("Top mounting" or "Bottom mounting").

If the end of the actuator is used to fix the main body (end mounting), the excessive load acts on the actuator, which adversely affects the operation and life of the product.

Handling

Caution

1. INP output signal

1) Positioning operation

When the product comes within the set range by step data [In position], the INP output signal will turn on.
Initial value: Set to [0.50] or higher.

2) Pushing operation

When the effective force exceeds step data [Trigger LV], the INP output signal will turn on.

Use the product within the specified range of [Pushing force] and [Trigger LV].

a) To ensure that the actuator pushes the workpiece with the set [Pushing force], it is recommended that the [Trigger LV] be set to the same value as the [Pushing force].

b) When the [Pushing force] and [Trigger LV] are set less than the specified range, the INP output signal will turn on from the pushing start position.

Handling

Caution

<Pushing Force and Trigger Level Range> Without load/With lateral load on rod end

Model	Pushing speed [mm/s]	Pushing force (Setting input value)	Model	Pushing speed [mm/s]	Pushing force (Setting input value)
LEY□16□	1 to 4	30 % to 85 %	LEY□16□A	1 to 4	40 % to 95 %
	5 to 20	35 % to 85 %		5 to 20	60 % to 95 %
	21 to 50	60 % to 85 %		21 to 50	80 % to 95 %
LEY□25□	1 to 4	20 % to 65 %	LEY□25□A	1 to 4	40 % to 95 %
	5 to 20	35 % to 65 %		5 to 20	60 % to 95 %
	21 to 35	50 % to 65 %		21 to 35	80 % to 95 %
LEY□32□	1 to 4	20 % to 85 %			
	5 to 20	35 % to 85 %			
	21 to 30	60 % to 85 %			
LEY□40□	1 to 4	20 % to 65 %			
	5 to 20	35 % to 65 %			
	21 to 30	50 % to 65 %			

<Set values for Vertical Upward Transfer Pushing Operation>

* For vertical loads (upward), set the pushing force to the maximum value shown below, and operate at the work load or less.

Model	LEY16□			LEY25□			LEY32□			LEY40□		
Lead	A	B	C	A	B	C	A	B	C	A	B	C
Work load [kg]	1	1.5	3	2.5	5	10	4.5	9	18	7	14	28
Pushing force	85 %			65 %			85 %			65 %		

Model	LEY16□A			LEY25□A		
Lead	A	B	C	A	B	C
Work load [kg]	1	1.5	3	1.2	2.5	5
Pushing force	95 %			95 %		

Model	LEYG16 ^M □			LEYG25 ^M □			LEYG32 ^M □			LEYG40 ^M □		
Lead	A	B	C	A	B	C	A	B	C	A	B	C
Work load [kg]	0.5	1	2.5	1.5	4	9	2.5	7	16	5	12	26
Pushing force	85 %			65 %			85 %			65 %		

Model	LEYG16 ^M □A			LEYG25 ^M □A		
Lead	A	B	C	A	B	C
Work load [kg]	0.5	1	2.5	0.5	1.5	4
Pushing force	95 %			95 %		

2. When the pushing operation is used, be sure to set to [Pushing operation].

Also, do not hit the workpiece in positioning operation or in the range of positioning operation. It may malfunction.

3. Use the product within the specified pushing speed range for the pushing operation.

It may lead to damage and malfunction.

4. The moving force should be the initial value (LEY16□/25□/32□/40□: 100 %, LEY16A□: 150 %, LEY25A□: 200 %).

If the moving force is set below the initial value, it may cause an alarm.

5. The actual speed of this actuator is affected by the load.

Check the model selection section of the catalogue.

6. Do not apply a load, impact or resistance in addition to the transferred load during return to origin.

Otherwise, the origin can be displaced since it is based on detected motor torque.

Series LEY/LEYG

Electric Actuators/ Specific Product Precautions 2



Be sure to read before handling. Refer to back cover for Safety Instructions and the Operation Manual for Electric Actuator Precautions.
Please download it via our website, <http://www.smc.eu>

Handling

Caution

7. In pushing operation, set the product to a position of at least 2 mm away from a workpiece. (This position is referred to as a pushing start position.)

The following alarms may be generated and operation may become unstable.

- a. "Posn failed" alarm is generated.

The product cannot reach a pushing start position due to variation in the target position.

- b. "Pushing ALM" alarm is generated.

The product is pushed back from a pushing start position after starting to push.

8. Do not scratch or dent the sliding parts of the piston rod, by striking or attaching objects.

The piston rod and guide rod are manufactured to precise tolerances, even a slight deformation may cause malfunction.

9. When an external guide is used, connect it in such a way that no impact or load is applied to it.

Use a freely moving connector (such as a floating joint).

10. Do not operate by fixing the piston rod and moving the actuator body.

Excessive load will be applied to the piston rod, leading to damage to the actuator and reduced the life of the product. When an actuator is operated with one end fixed and the other free (ends tapped or flange type), a bending moment may act on the actuator due to vibration generated at the stroke end, which can damage the actuator. In such a case, install a mounting bracket to suppress the vibration of the actuator body or reduce the speed so that the actuator does not vibrate at the stroke end. Also, use a mounting bracket when moving the actuator body or when a long stroke actuator is mounted horizontally and fixed at one end.

11. Avoid using the electric actuator in such a way that rotational torque would be applied to the piston rod.

This may cause deformation of the non-rotating guide, abnormal responses of the auto switch, play in the internal guide or an increase in the sliding resistance.

Refer to the table below for the approximate values of the allowable range of rotational torque.

Allowable rotational torque (N·m) or less	LEY16□□	LEY25□□	LEY32/40□□
	0.8	1.1	1.4

When screwing in a bracket or nut to the end of the piston rod, hold the flats of the rod end with a wrench (the piston rod should be fully retracted). Do not apply tightening torque to the non-rotating mechanism.

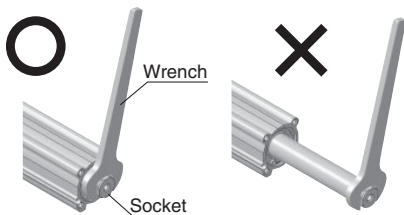

12. When rotational torque is applied to the end of the plate, use it within the allowable range. [Series LEYG]

This may cause deformation of the guide rod and bushing, play in the guide or an increase in the sliding resistance.

13. For the pushing operation, use the product within duty ratio range below.

The duty ratio is a ratio at the time that can keep being pushed.

• Step motor (Servo/24 VDC)

LEY16□

Pushing force [%]	Ambient temperature: 25 °C or less		Ambient temperature: 40 °C	
	Duty ratio [%]	Continuous pushing time [minute]	Duty ratio [%]	Continuous pushing time [minute]
40 or less	100	—	100	—
50			70	12
70			20	1.3
85			15	0.8

LEY25□

Pushing force [%]	Ambient temperature: 25 °C or less		Ambient temperature: 40 °C	
	Duty ratio [%]	Continuous pushing time [minute]	Duty ratio [%]	Continuous pushing time [minute]
65 or less	100	—	100	—

LEY32□

Pushing force [%]	Ambient temperature: 25 °C or less		Ambient temperature: 40 °C	
	Duty ratio [%]	Continuous pushing time [minute]	Duty ratio [%]	Continuous pushing time [minute]
65 or less	100	—	100	—
85			50	15

LEY40□

Pushing force [%]	Ambient temperature: 25 °C or less		Ambient temperature: 40 °C	
	Duty ratio [%]	Continuous pushing time [minute]	Duty ratio [%]	Continuous pushing time [minute]
65 or less	100	—	100	—

• Servo motor (24 VDC)

LEY16A□

Pushing force [%]	Ambient temperature: 25 °C or less		Ambient temperature: 40 °C	
	Duty ratio [%]	Continuous pushing time [minute]	Duty ratio [%]	Continuous pushing time [minute]
95 or less	100	—	100	—

LEY25A□

Pushing force [%]	Ambient temperature: 25 °C or less		Ambient temperature: 40 °C	
	Duty ratio [%]	Continuous pushing time [minute]	Duty ratio [%]	Continuous pushing time [minute]
95 or less	100	—	100	—

14. When mounting the product, keep the 40 mm or more for bending the cable.

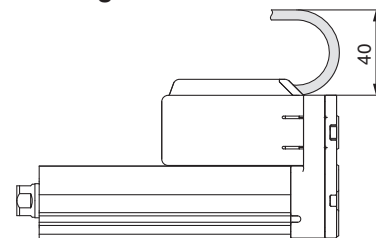

15. When mounting a bolt, workpiece or jig, hold the flats of the piston rod end with a wrench so that the piston rod does not rotate. The bolt should be tightened within the specified torque range.

This may cause abnormal responses of the auto switch, play in the internal guide or an increase in the sliding resistance.

Electric Actuators/ Specific Product Precautions 3



Be sure to read before handling. Refer to back cover for Safety Instructions and the Operation Manual for Electric Actuator Precautions. Please download it via our website, <http://www.smc.eu>

Handling

⚠ Caution

16. When mounting the product and/or workpiece, tighten the mounting screws within the specified torque range.

Tightening with higher torque than the specified range may cause malfunction while the tightening with lower torque can cause the displacement of gripping position or dropping a workpiece.

<Series LEY>

Workpiece fixed/Rod end female thread

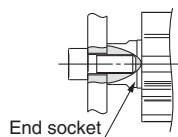

Model	Bolt	Max. tightening torque [N·m]	Max. screw-in depth [mm]	End socket width across flats [mm]
LEY16	M5 x 0.8	3.0	10	14
LEY25	M8 x 1.25	12.5	13	17
LEY32/40	M8 x 1.25	12.5	13	22

Workpiece fixed/Rod end male thread (When "Rod end male thread" is selected.)

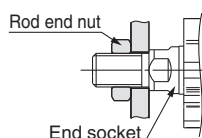

Model	Thread size	Max. tightening torque [N·m]	Effective thread length [mm]	End socket width across flats [mm]
LEY16	M8 x 1.25	12.5	12	14
LEY25	M14 x 1.5	65.0	20.5	17
LEY32/40	M14 x 1.5	65.0	20.5	22

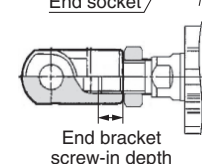

Model	Rod end nut		End bracket screw-in depth [mm]
	Width across flats [mm]	Length [mm]	
LEY16	13	5	5 or more
LEY25	22	8	8 or more
LEY32/40	22	8	8 or more

* Rod end nut is an accessory.

Body fixed/Body bottom tapped style (When "Body bottom tapped" is selected.)

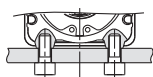

Model	Bolt	Max. tightening torque [N·m]	Max. screw-in depth [mm]
LEY16	M4 x 0.7	1.5	5.5
LEY25	M5 x 0.8	3.0	6.5
LEY32/40	M6 x 1.0	5.2	8.8

Body fixed/Rod side/Head side tapped style

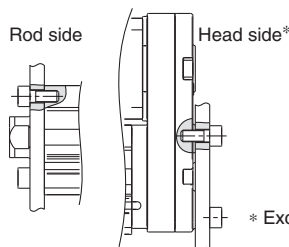

Model	Bolt	Max. tightening torque [N·m]	Max. screw-in depth [mm]
LEY16	M4 x 0.7	1.5	7
LEY25	M5 x 0.8	3.0	8
LEY32/40	M6 x 1.0	5.2	10

* Except the LEY□D.

<Series LEYG>

Workpiece fixed/Plate tapped style

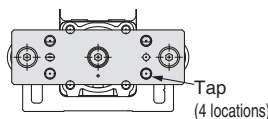

Model	Bolt	Max. tightening torque [N·m]	Max. screw-in depth [mm]
LEYG16 ^M	M5 x 0.8	3.0	8
LEYG25 ^M	M6 x 1.0	5.2	11
LEYG ^{32M} / _{40L}	M6 x 1.0	5.2	12

Body fixed/Top mounting

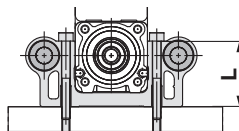

Model	Bolt	Max. tightening torque [N·m]	Length: L [mm]
LEYG16 ^M	M4 x 0.7	1.5	31.8
LEYG25 ^M	M5 x 0.8	3.0	40.3
LEYG ^{32M} / _{40L}	M5 x 0.8	3.0	50.3

Body fixed/Bottom mounting

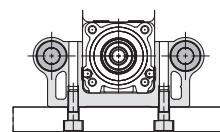

Model	Bolt	Max. tightening torque [N·m]	Max. screw-in depth [mm]
LEYG16 ^M	M5 x 0.8	3.0	10
LEYG25 ^M	M6 x 1.0	5.2	12
LEYG ^{32M} / _{40L}	M6 x 1.0	5.2	12

Body fixed/Head side tapped style

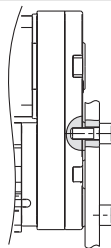

Model	Bolt	Max. tightening torque [N·m]	Max. screw-in depth [mm]
LEYG16 ^M	M4 x 0.7	1.5	7
LEYG25 ^M	M5 x 0.8	3.0	8
LEYG ^{32M} / _{40L}	M6 x 1.0	5.2	10

17. Keep the flatness of the mounting surface within the following ranges when mounting the actuator body and workpiece.

Unevenness of a workpiece or base mounted on the body of the product may cause an increase in the sliding resistance.

Model	Mounting position	Flatness
LEY□	Body/Body bottom	0.02 mm or less
LEYG□	Top mounting/Bottom mounting	0.02 mm or less
	Workpiece/Plate mounting	0.05 mm or less

18. When using auto switch with the guide rod type LEYG series, the following limits will be in effect. Please select the product while paying attention to this.

- Insert the auto switch from the front side with rod (plate) sticking out.
- For the parts hidden behind the guide attachment (Rod stick out side), the auto switch cannot be fixed.
- Consult with SMC when using auto switch on the rod stick out side.



Series LEY/LEYG

Electric Actuators/ Specific Product Precautions 4

Be sure to read before handling. Refer to back cover for Safety Instructions and the Operation Manual for Electric Actuator Precautions.
Please download it via our website, <http://www.smc.eu>

Enclosure

IP -

First characteristic numeral • Second characteristic numeral

• First Characteristics:

Degrees of protection against solid foreign objects

0	Non-protected
1	Protected against solid foreign objects of 50 mmø and greater
2	Protected against solid foreign objects of 12 mmø and greater
3	Protected against solid foreign objects of 2.5 mmø and greater
4	Protected against solid foreign objects of 1.0 mmø and greater
5	Dust-protected
6	Dust-tight

• Second Characteristics:

Degrees of protection against water

0	Non-protected	—
1	Protected against vertically falling water drops	Drip-proof type 1
2	Protected against vertically falling water drops when enclosure tilted up to 15°	Drip-proof type 2
3	Protected against rainfall when enclosure tilted up to 60°	Rain-proof type
4	Protected against splashing water	Splash-proof type
5	Protected against water jets	Water-jet-proof type
6	Protected against powerful water jets	Powerful water-jet-proof type
7	Protected against the effects of temporary immersion in water	Immersible type
8	Protected against the effects of continuous immersion in water	Submersible type

Example) In the case of stipulated as IP65, we can know the degrees of protection is dust-tight and water-jet-proof on the grounds that the first characteristic numeral is "6" and the second characteristic numeral is "5" respectively, that gives it will not be adversely affected by direct water jets from any direction.
(* The water jets which are "5" of the second characteristic numeral based on JIS C 0920 (2003) indicates a flow of water for 3 minutes at 12.5 L per minute.)

Maintenance

⚠ Warning

1. Ensure that the power supply is stopped and the workpiece is removed before starting maintenance work or replacement of the product.

• Maintenance frequency

Perform maintenance according to the table below.

Frequency	Appearance check	Belt check
Inspection before daily operation	○	—
Inspection every 6 months/ 250 km/5 million cycles*	○	○

* Select whichever comes sooner.

• Items for visual appearance check

1. Loose set screws, Abnormal dirt
2. Check of flaw and cable joint
3. Vibration, Noise

• Items for belt check

Stop operation immediately and replace the belt when belt appear to be below. Further, ensure your operating environment and conditions satisfy the requirements specified for the product.

a. Tooth shape canvas is worn out

Canvas fiber becomes fuzzy. Rubber is removed and the fiber becomes whitish. Lines of fibers become unclear.

b. Peeling off or wearing of the side of the belt

Belt corner becomes round and frayed thread sticks out.

c. Belt partially cut

Belt is partially cut. Foreign matter caught in teeth other than cut part causes flaw.

d. Vertical line of belt teeth

Flaw which is made when the belt runs on the flange.

e. Rubber back of the belt is softened and sticky

f. Crack on the back of the belt

Model Selection

Servo Motor (24 VDC)/Step Motor (Servo/24 VDC)

LEY

LEYG

LECA6
LECP6

LEC-G

LECP1

LECPA

JXC□1

JXC7/3/3/3/2/3/3

LEY

LEYG

LECS□

LECS-T

LECY□

Specific Product Precautions

Controller/Driver

Step Data Input Type Page 65



Step Motor (Servo/24 VDC)
Series LECPC6



Servo Motor (24 VDC)
Series LECA6

Gateway Unit Page 77



Series LEC-G

Programless Type Page 80

Pulse Input Type Page 87



Step Motor (Servo/24 VDC)
Series LECPC1



Step Motor (Servo/24 VDC)
Series LECPC1

Model Selection

LECY

LECA6

LECP6

LECG

LECP1

LECPA

JXC01

JXC7303/92/93

LECY

LECA6

LECP6

LECG

LECP1

LECPA

JXC01

JXC7303/92/93

LECY

LECA6

LECP6

LECG

LECP1

LECPA

JXC01

JXC7303/92/93

LECY

LECA6

LECP6

LECG

LECP1

LECPA

JXC01

JXC7303/92/93

LECY

LECA6

LECP6

LECG

LECP1

LECPA

JXC01

JXC7303/92/93

LECY

LECA6

LECP6

LECG

LECP1

LECPA

JXC01

JXC7303/92/93

LECY

LECA6

LECP6

LECG

LECP1

LECPA

JXC01

JXC7303/92/93

LECY

LECA6

LECP6

LECG

LECP1

LECPA

JXC01

JXC7303/92/93

LECY

LECA6

LECP6

LECG

LECP1

LECPA

JXC01

JXC7303/92/93

LECY

LECA6

LECP6

LECG

LECP1

LECPA

JXC01

JXC7303/92/93

LECY

LECA6

LECP6

LECG

LECP1

LECPA

JXC01

JXC7303/92/93

LECY

LECA6

LECP6

LECG

LECP1

LECPA

JXC01

JXC7303/92/93

LECY

LECA6

LECP6

LECG

LECP1

LECPA

JXC01

JXC7303/92/93

LECY

LECA6

LECP6

LECG

LECP1

LECPA

JXC01

JXC7303/92/93

LECY

LECA6

LECP6

LECG

LECP1

LECPA

JXC01

JXC7303/92/93

LECY

LECA6

LECP6

LECG

LECP1

LECPA

JXC01

JXC7303/92/93

LECY

LECA6

LECP6

LECG

LECP1

LECPA

JXC01

JXC7303/92/93

LECY

LECA6

LECP6

LECG

LECP1

LECPA

JXC01

JXC7303/92/93

LECY

LECA6

LECP6

LECG

LECP1

LECPA

JXC01

JXC7303/92/93

LECY

LECA6

LECP6

LECG

LECP1

LECPA

JXC01

JXC7303/92/93

LECY

LECA6

LECP6

LECG

LECP1

LECPA

JXC01

JXC7303/92/93

LECY

LECA6

LECP6

LECG

LECP1

LECPA

JXC01

JXC7303/92/93

LECY

LECA6

LECP6

LECG

LECP1

LECPA

JXC01

JXC7303/92/93

LECY

LECA6

LECP6

LECG

LECP1

LECPA

JXC01

JXC7303/92/93

LECY

LECA6

LECP6

LECG

LECP1

LECPA

JXC01

JXC7303/92/93

LECY

LECA6

LECP6

LECG

LECP1

LECPA

JXC01

JXC7303/92/93

LECY

LECA6

LECP6

LECG

LECP1

LECPA

JXC01

JXC7303/92/93

LECY

LECA6

LECP6

LECG

LECP1

LECPA

JXC01

JXC7303/92/93

LECY

LECA6

LECP6

LECG

LECP1

LECPA

JXC01

JXC7303/92/93

LECY

LECA6

LECP6

LECG

LECP1

LECPA

JXC01

JXC7303/92/93

LECY

LECA6

LECP6

LECG

LECP1

LECPA

JXC01

JXC7303/92/93

LECY

LECA6

LECP6

LECG

LECP1

LECPA

JXC01

JXC7303/92/93

LECY

LECA6

LECP6

LECG

LECP1

LECPA

JXC01

JXC7303/92/93

LECY

LECA6

LECP6

LECG

LECP1

LECPA

JXC01

JXC7303/92/93

LECY

Step Data Input Type

Step Motor (Servo/24 VDC)

Series LECP6

Servo Motor (24 VDC)

Series LECA6



Series LECP6 Series LECA6



How to Order

⚠ Caution

[CE-compliant products]

① EMC compliance was tested by combining the electric actuator LE series and the controller LEC series.

The EMC depends on the configuration of the customer's control panel and the relationship with other electrical equipment and wiring. Therefore, conformity to the EMC directive cannot be certified for SMC components incorporated into the customer's equipment under actual operating conditions. As a result, it is necessary for the customer to verify conformity to the EMC directive for the machinery and equipment as a whole.

② For the LECA6 series (servo motor controller), EMC compliance was tested by installing a noise filter set (LEC-NFA). Refer to page 73 for the noise filter set. Refer to the LECA Operation Manual for installation.

[UL-compliant products]

When conformity to UL is required, the electric actuator and controller should be used with a UL1310 Class 2 power supply.

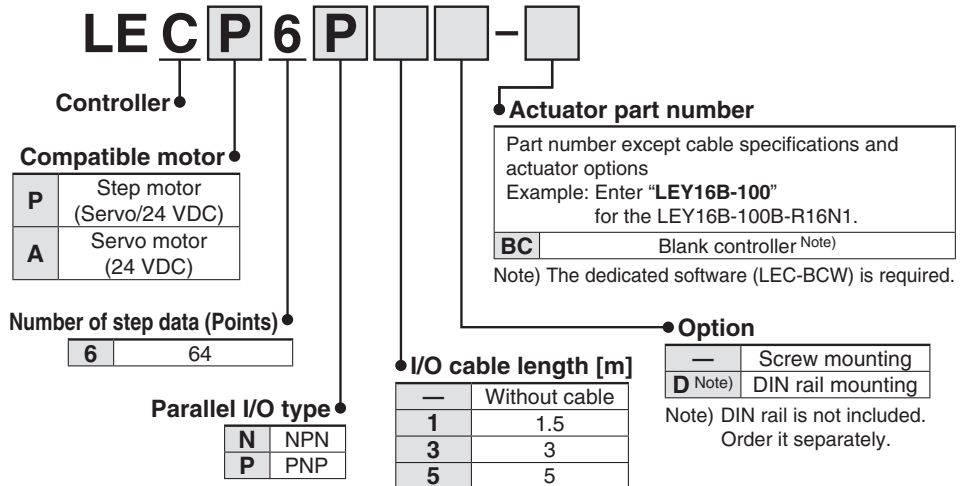

* When controller equipped type is selected when ordering the LE series, you do not need to order this controller.

The controller is sold as single unit after the compatible actuator is set.

Confirm that the combination of the controller and the actuator is correct.

<Check the following before use.>

- ① Check the actuator label for model number. This matches the controller.
- ② Check Parallel I/O configuration matches (NPN or PNP).

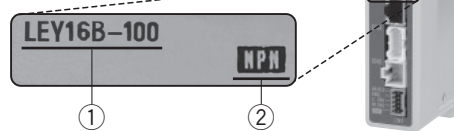

Precautions on blank controller (LECP6□□-BC)

Blank controller is a controller to which the customer can write the data of the actuator to be combined and used. Use the dedicated software (LEC-BCW) for data writing.

- Please download the dedicated software (LEC-BCW) via our website.
- Order the controller setting kit (LEC-W2) separately to use this software.

SMC website
<http://www.smc.eu>

* Refer to the operation manual for using the products. Please download it via our website, <http://www.smc.eu>

Specifications

Basic Specifications

Item	LECP6	LECA6
Compatible motor	Step motor (Servo/24 VDC)	Servo motor (24 VDC)
Power supply ^{Note 1)}	Power voltage: 24 VDC ±10 % ^{Note 2)} [Including motor drive power, control power, stop, lock release]	Power voltage: 24 VDC ±10 % ^{Note 2)} [Including motor drive power, control power, stop, lock release]
Parallel input	11 inputs (Photo-coupler isolation)	
Parallel output	13 outputs (Photo-coupler isolation)	
Compatible encoder	Incremental A/B phase (800 pulse/rotation)	Incremental A/B (800 pulse/rotation)/Z phase
Serial communication	RS485 (Modbus protocol compliant)	
Memory	EEPROM	
LED indicator	LED (Green/Red) one of each	
Lock control	Forced-lock release terminal ^{Note 3)}	
Cable length [m]	I/O cable: 5 or less, Actuator cable: 20 or less	
Cooling system	Natural air cooling	
Operating temperature range [°C]	0 to 40 (No freezing)	
Operating humidity range [%RH]	90 or less (No condensation)	
Storage temperature range [°C]	-10 to 60 (No freezing)	
Storage humidity range [%RH]	90 or less (No condensation)	
Insulation resistance [MΩ]	Between the housing and SG terminal: 50 (500 VDC)	
Weight [g]	150 (Screw mounting), 170 (DIN rail mounting)	

Note 1) Do not use the power supply of "inrush current prevention type" for the controller power supply. When conformity to UL is required, the electric actuator and controller should be used with a UL1310 Class 2 power supply.

Note 2) The power consumption changes depending on the actuator model. Refer to the specifications of actuator for more details.

Note 3) Applicable to non-magnetizing lock.

How to Mount

a) Screw mounting (LEC□6□□-□) (Installation with two M4 screws)

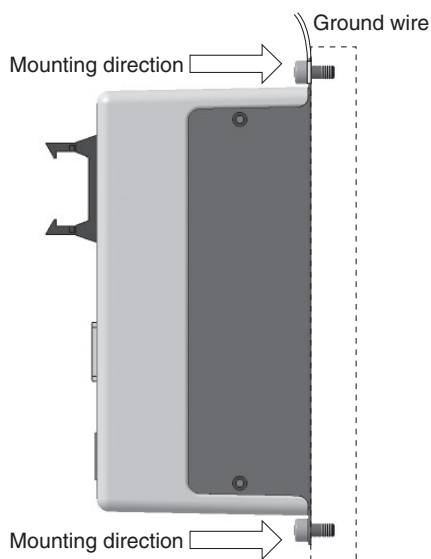

b) DIN rail mounting (LEC□6□□D-□) (Installation with the DIN rail)

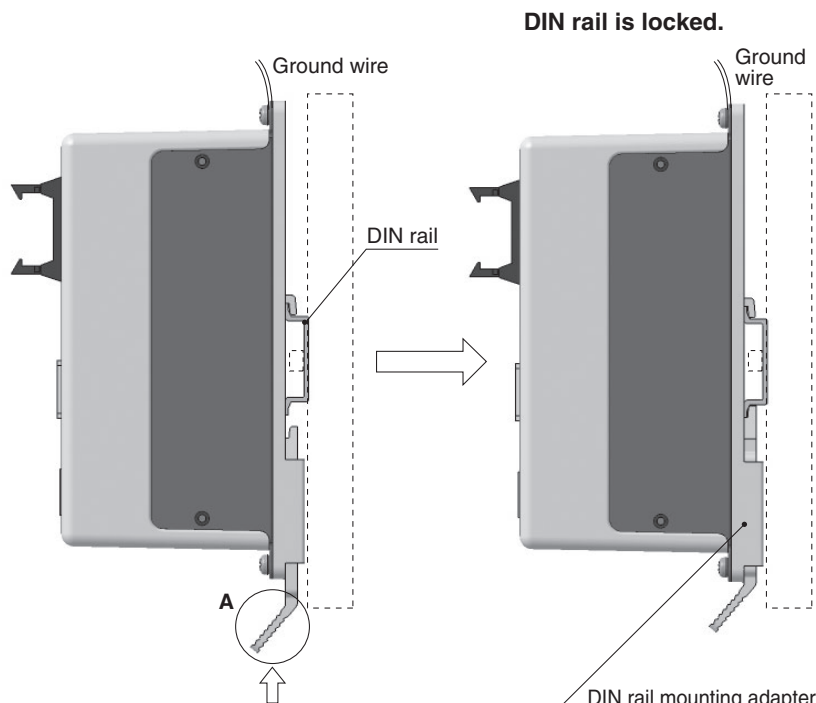

Hook the controller on the DIN rail and press the lever of section **A** in the arrow direction to lock it.

Note) When size 25 or more of the LE series are used, the space between the controllers should be 10 mm or more.

DIN rail AXT100-DR-□

* For □, enter a number from the "No." line in the table below.
 Refer to the dimensions on page 67 for the mounting dimensions.

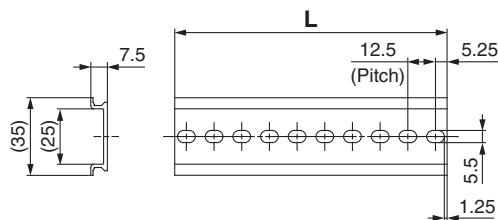

L Dimension [mm]

No.	1	2	3	4	5	6	7	8	9	10	11	12	13	14	15	16	17	18	19	20
L	23	35.5	48	60.5	73	85.5	98	110.5	123	135.5	148	160.5	173	185.5	198	210.5	223	235.5	248	260.5
No.	21	22	23	24	25	26	27	28	29	30	31	32	33	34	35	36	37	38	39	40
L	273	285.5	298	310.5	323	335.5	348	360.5	373	385.5	398	410.5	423	435.5	448	460.5	473	485.5	498	510.5

DIN rail mounting adapter LEC-D0 (with 2 mounting screws)

This should be used when the DIN rail mounting adapter is mounted onto the screw mounting type controller afterward.

Model Selection

Servo Motor (Servo/24 VDC)
LEY

Servo Motor (24 VDC)/Step Motor (Servo/24 VDC)
LEYG

LECA6
LECP6

LEC-G

LECP1

LECPA

JXC□1

JXC7□□□□□□

AC Servo Motor
LEY

LEYG

LECS□

LECS-T

LECY□

Specific Product Precautions

Series LECP6

Series LECA6

Dimensions

a) Screw mounting (LEC□6□□-□)

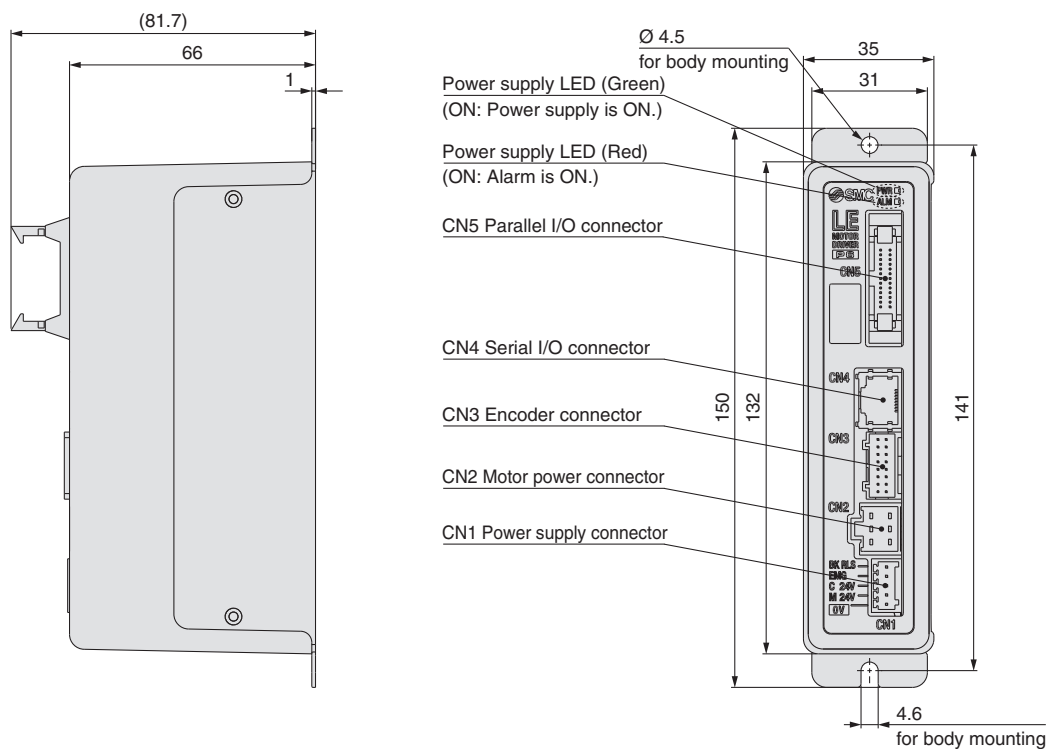

b) DIN rail mounting (LEC□6□□D-□)

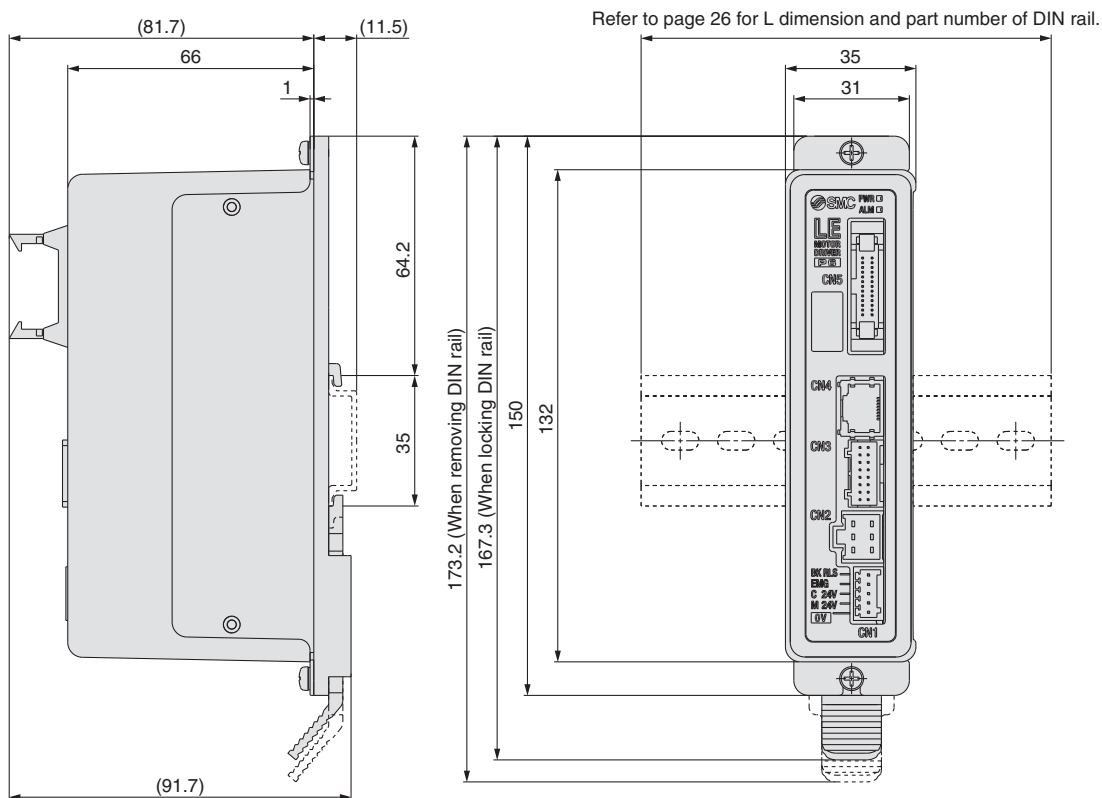

Step Data Input Type/Step Motor (Servo/24 VDC) **Series LECP6**

Step Data Input Type/Servo Motor (24 VDC) **Series LECA6**

Wiring Example 1

Power Supply Connector: CN1 * Power supply plug is an accessory.

CN1 Power Supply Connector Terminal for LECP6 (PHOENIX CONTACT FK-MC0.5/5-ST-2.5)

Terminal name	Function	Details
0V	Common supply (-)	M 24V terminal/C 24V terminal/EMG terminal/BK RLS terminal are common (-).
M 24V	Motor power supply (+)	Motor power supply (+) supplied to the controller
C 24V	Control power supply (+)	Control power supply (+) supplied to the controller
EMG	Stop (+)	Input (+) for releasing the stop
BK RLS	Lock release (+)	Input (+) for releasing the lock

Power supply plug for LECP6

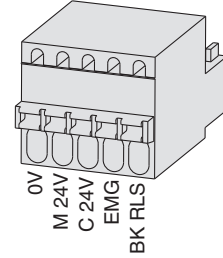

CN1 Power Supply Connector Terminal for LECA6 (PHOENIX CONTACT FK-MC0.5/7-ST-2.5)

Terminal name	Function	Details
0V	Common supply (-)	M 24V terminal/C 24V terminal/EMG terminal/BK RLS terminal are common (-).
M 24V	Motor power supply (+)	Motor power supply (+) supplied to the controller
C 24V	Control power supply (+)	Control power supply (+) supplied to the controller
EMG	Stop (+)	Input (+) for releasing the stop
BK RLS	Lock release (+)	Input (+) for releasing the lock
RG+	Regenerative output 1	Regenerative output terminals for external connection
RG-	Regenerative output 2	(Not necessary to connect them in the combination with the LE series standard specifications.)

Power supply plug for LECA6

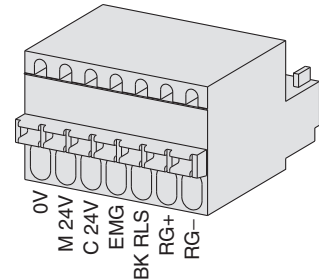

Wiring Example 2

Parallel I/O Connector: CN5 * When you connect a PLC etc., to the CN5 parallel I/O connector, use the I/O cable (LEC-CN5-□).
* The wiring should be changed depending on the type of the parallel I/O (NPN or PNP).

Wiring diagram

LEC□6N□□-□ (NPN)

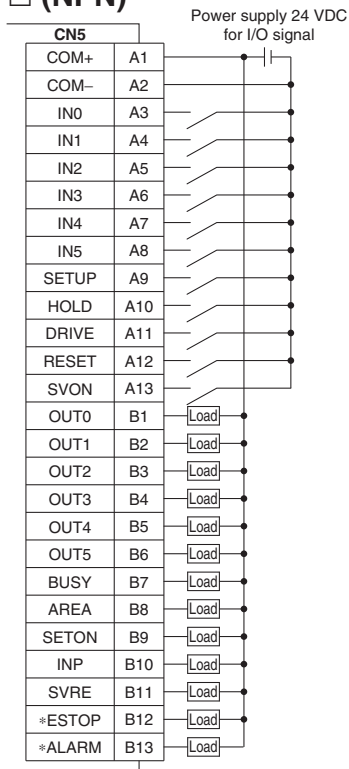

LEC□6P□□-□ (PNP)

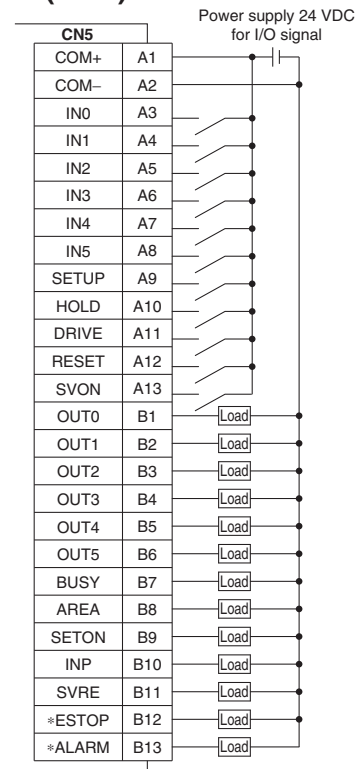

Input Signal

Name	Details
COM+	Connects the power supply 24 V for input/output signal
COM-	Connects the power supply 0 V for input/output signal
IN0 to IN5	Step data specified Bit No. (Input is instructed in the combination of IN0 to 5.)
SETUP	Instruction to return to origin
HOLD	Operation is temporarily stopped
DRIVE	Instruction to drive
RESET	Alarm reset and operation interruption
SVON	Servo ON instruction

Output Signal

Name	Details
OUT0 to OUT5	Outputs the step data no. during operation
BUSY	Outputs when the actuator is moving
AREA	Outputs within the step data area output setting range
SETON	Outputs when returning to origin
INP	Outputs when target position or target force is reached (Turns on when the positioning or pushing is completed.)
SVRE	Outputs when servo is on
*ESTOP (Note)	Not output when EMG stop is instructed
*ALARM (Note)	Not output when alarm is generated

Note) Signal of negative-logic circuit (N.C.)

Model Selection

LEY

LEYG

LECA6
LECP6

LEC-G

LECP1

LECPA

JXC□1

JXC7□□□/□□□

LEY

LEYG

LECS□

LECS-T

LECY□

Specific Product Precautions

Series LECP6

Series LECA6

Step Data Setting

1. Step data setting for positioning

In this setting, the actuator moves toward and stops at the target position.

The following diagram shows the setting items and operation. The setting items and set values for this operation are stated below.

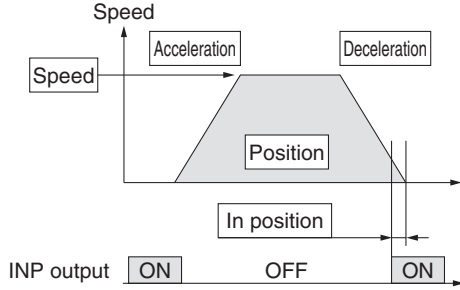

⊙ : Need to be set.
○ : Need to be adjusted as required.
— : Setting is not required.

Step Data (Positioning)

Necessity	Item	Details
⊙	Movement MOD	When the absolute position is required, set Absolute. When the relative position is required, set Relative.
⊙	Speed	Transfer speed to the target position
⊙	Position	Target position
○	Acceleration	Parameter which defines how rapidly the actuator reaches the speed set. The higher the set value, the faster it reaches the speed set.
○	Deceleration	Parameter which defines how rapidly the actuator comes to stop. The higher the set value, the quicker it stops.
⊙	Pushing force	Set 0. (If values 1 to 100 are set, the operation will be changed to the pushing operation.)
—	Trigger LV	Setting is not required.
—	Pushing speed	Setting is not required.
○	Moving force	Max. torque during the positioning operation (No specific change is required.)
○	Area 1, Area 2	Condition that turns on the AREA output signal.
○	In position	Condition that turns on the INP output signal. When the actuator enters the range of [in position], the INP output signal turns on. (It is unnecessary to change this from the initial value.) When it is necessary to output the arrival signal before the operation is completed, make the value larger.

2. Step data setting for pushing

The actuator moves toward the pushing start position, and when it reaches that position, it starts pushing with the set force or less.

The following diagram shows the setting items and operation. The setting items and set values for this operation are stated below.

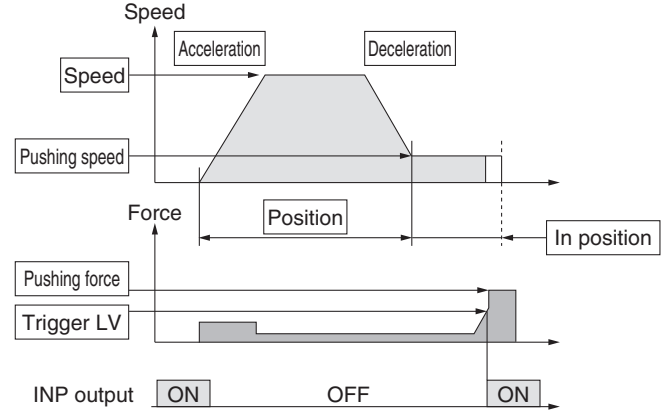

⊙ : Need to be set.
○ : Need to be adjusted as required.

Step Data (Pushing)

Necessity	Item	Details
⊙	Movement MOD	When the absolute position is required, set Absolute. When the relative position is required, set Relative.
⊙	Speed	Transfer speed to the pushing start position
⊙	Position	Pushing start position
○	Acceleration	Parameter which defines how rapidly the actuator reaches the speed set. The higher the set value, the faster it reaches the speed set.
○	Deceleration	Parameter which defines how rapidly the actuator comes to stop. The higher the set value, the quicker it stops.
⊙	Pushing force	Pushing force ratio is defined. The setting range differs depending on the electric actuator type. Refer to the Operation Manual for the electric actuator.
⊙	Trigger LV	Condition that turns on the INP output signal. The INP output signal turns on when the generated force exceeds the value. Trigger level should be the pushing force or less.
○	Pushing speed	Pushing speed during pushing. When the speed is set fast, the electric actuator and work pieces might be damaged due to the impact when they hit the end, so this set value should be smaller. Refer to the Operation Manual for the electric actuator.
○	Moving force	Max. torque during the positioning operation (No specific change is required.)
○	Area 1, Area 2	Condition that turns on the AREA output signal.
⊙	In position	Transfer distance during pushing. If the transferred distance exceeds the setting, it stops even if it is not pushing. If the transfer distance is exceeded, the INP output signal will not turn on.

Signal Timing

Return to Origin

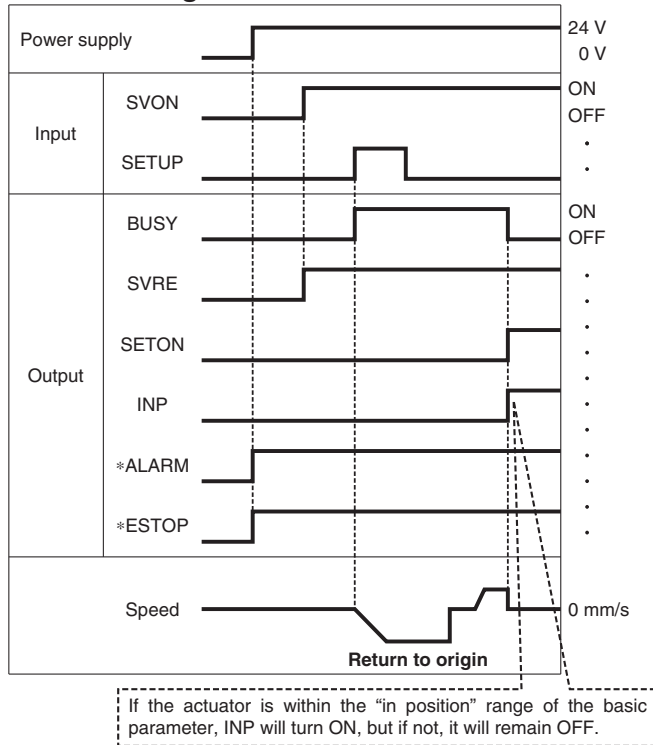

*"ALARM" and "*ESTOP" are expressed as negative-logic circuit.

Positioning Operation

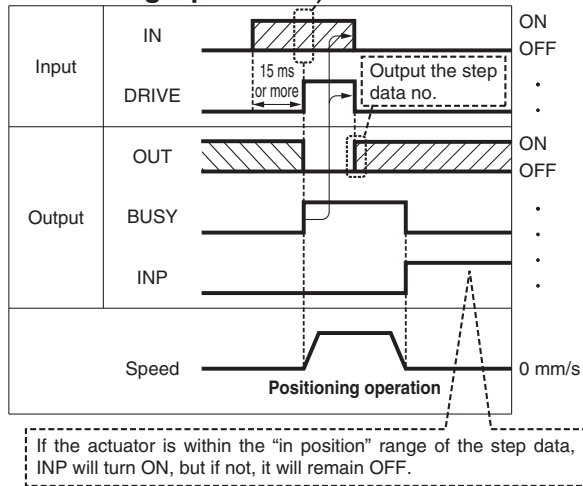

*"OUT" is output when "DRIVE" is changed from ON to OFF.
 (When power supply is applied, "DRIVE" or "RESET" is turned ON or "*ESTOP" is turned OFF, all of the "OUT" outputs are OFF.)

HOLD

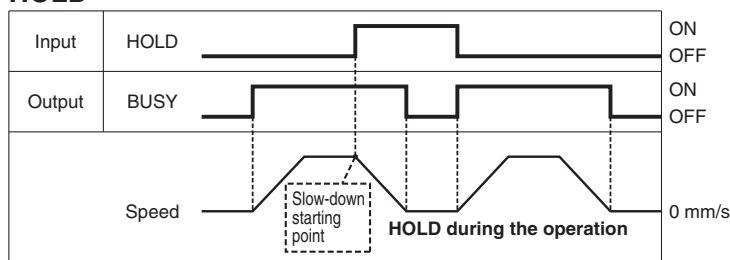

* When the actuator is in the positioning range in the pushing operation, it does not stop even if HOLD signal is input.

Pushing Operation

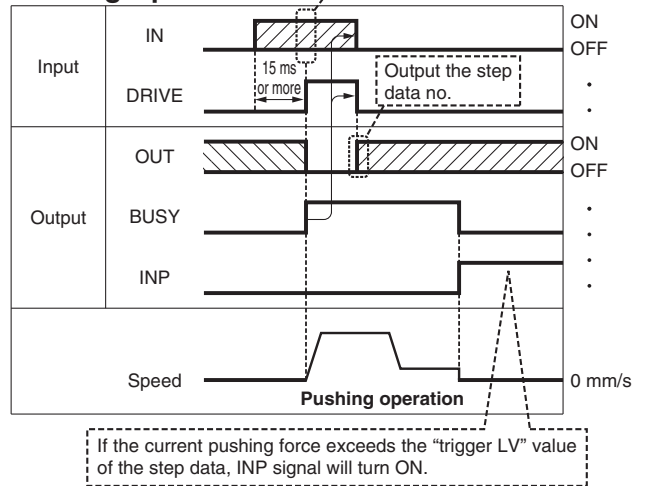

Reset

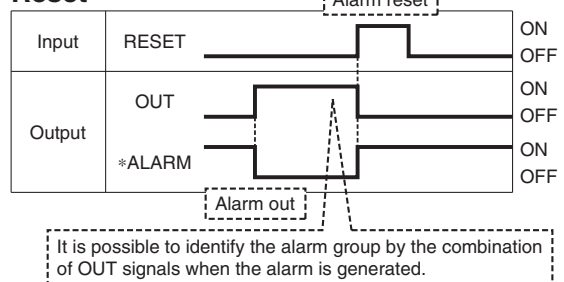

*"ALARM" is expressed as negative-logic circuit.

Model Selection

LECY

LEYG

LECA6
LECP6

LEC-G

LECP1

LECPA

JXC□1

JXC7□□□□□□

LECY

LEYG

LECS□

LECS-T

LECY□

Specific Product Precautions

Series LECP6

Series LECA6

Options: Actuator Cable

[Robotic cable, standard cable for step motor (Servo/24 VDC)]

LE-CP-1-

Cable length (L) [m]

1	1.5
3	3
5	5
8	8*
A	10*
B	15*
C	20*

* Produced upon receipt of order (Robotic cable only)

Cable type

-	Robotic cable (Flexible cable)
S	Standard cable

LE-CP-¹/₅/Cable length: 1.5 m, 3 m, 5 m

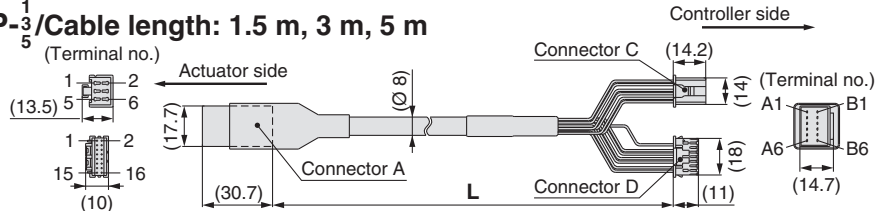

LE-CP-^{8 B}/_{A C}/Cable length: 8 m, 10 m, 15 m, 20 m
(* Produced upon receipt of order)

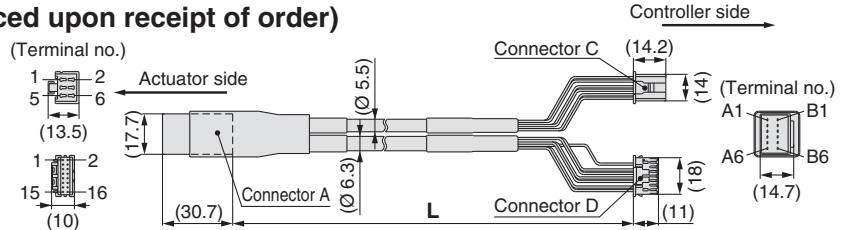

Signal	Connector A terminal no.	Connector C terminal no.	Cable colour	Connector D terminal no.
A	B-1	2	Brown	12
A	A-1	1	Red	13
B	B-2	6	Orange	7
B	A-2	5	Yellow	6
COM-A/COM	B-3	3	Green	9
COM-B/-	A-3	4	Blue	8
Shield				
Vcc	B-4	12	Brown	8
GND	A-4	13	Black	3
A	B-5	7	Red	
A	A-5	6	Black	
B	B-6	9	Orange	
B	A-6	8	Black	

[Robotic cable, standard cable with lock and sensor for step motor (Servo/24 VDC)]

LE-CP-1-B-

Cable length (L) [m]

1	1.5
3	3
5	5
8	8*
A	10*
B	15*
C	20*

* Produced upon receipt of order (Robotic cable only)

With lock and sensor

Cable type

-	Robotic cable (Flexible cable)
S	Standard cable

LE-CP-¹/₅/Cable length: 1.5 m, 3 m, 5 m

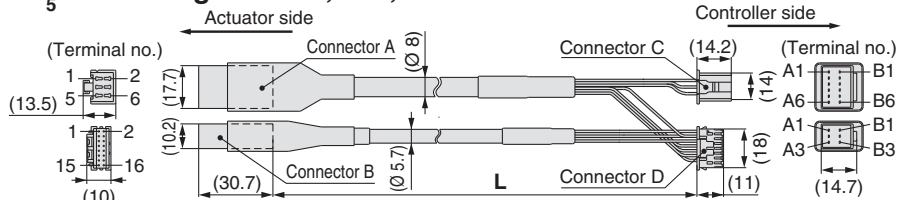

LE-CP-^{8 B}/_{A C}/Cable length: 8 m, 10 m, 15 m, 20 m
(* Produced upon receipt of order)

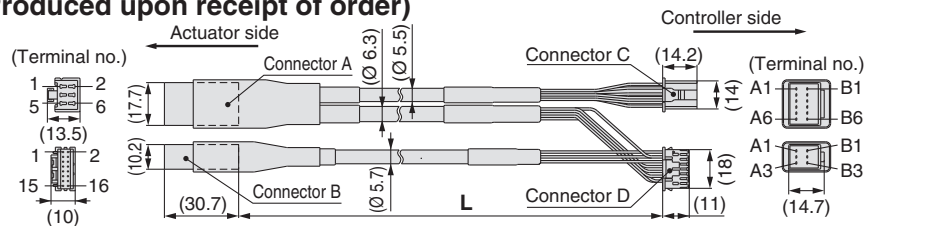

Signal	Connector A terminal no.	Connector C terminal no.	Cable colour	Connector D terminal no.
A	B-1	2	Brown	12
A	A-1	1	Red	13
B	B-2	6	Orange	7
B	A-2	5	Yellow	6
COM-A/COM	B-3	3	Green	9
COM-B/-	A-3	4	Blue	8
Shield				
Vcc	B-4	12	Brown	8
GND	A-4	13	Black	3
A	B-5	7	Red	
A	A-5	6	Black	
B	B-6	9	Orange	
B	A-6	8	Black	
Shield				
Lock (+)	B-1	4	Red	
Lock (-)	A-1	5	Black	
Sensor (+) (Note)	B-3	1	Brown	
Sensor (-) (Note)	A-3	2	Blue	

[Robotic cable for servo motor (24 VDC)]

LE-CA-1

Cable length (L) [m]

1	1.5
3	3
5	5
8	8*
A	10*
B	15*
C	20*

* Produced upon receipt of order

LE-CA-□

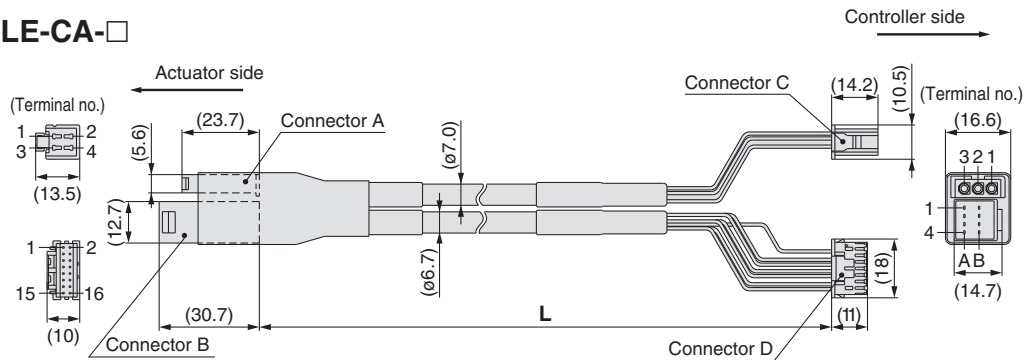

Signal	Connector A terminal no.	Cable colour	Connector C terminal no.
U	1	Red	1
V	2	White	2
W	3	Black	3

Signal	Connector B terminal no.	Cable colour	Connector D terminal no.
Vcc	B-1	Brown	12
GND	A-1	Black	13
A	B-2	Red	7
A	A-2	Black	6
B	B-3	Orange	9
B	A-3	Black	8
Z	B-4	Yellow	11
Z	A-4	Black	10
		—	3

Shield

Connection of shield material

[Robotic cable with lock and sensor for servo motor (24 VDC)]

LE-CA-1-B

Cable length (L) [m]

1	1.5
3	3
5	5
8	8*
A	10*
B	15*
C	20*

* Produced upon receipt of order

With lock and sensor

LE-CA-□-B

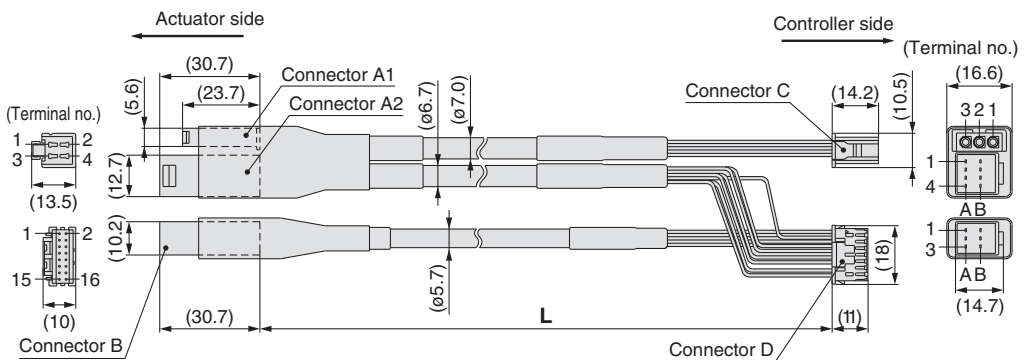

Signal	Connector A1 terminal no.	Cable colour	Connector C terminal no.
U	1	Red	1
V	2	White	2
W	3	Black	3

Signal	Connector A2 terminal no.	Cable colour	Connector D terminal no.
Vcc	B-1	Brown	12
GND	A-1	Black	13
A	B-2	Red	7
A	A-2	Black	6
B	B-3	Orange	9
B	A-3	Black	8
Z	B-4	Yellow	11
Z	A-4	Black	10
		—	3

Signal	Connector B terminal no.	Cable colour	Connector D terminal no.
Lock (+)	B-1	Red	4
Lock (-)	A-1	Black	5
Sensor (+) ^{Note)}	B-3	Brown	1
Sensor (-) ^{Note)}	A-3	Black	2

Shield

Connection of shield material

Model Selection

LEY

LEYG

LECA6
LECP6

LEC-G

LECP1

LECPA

JXC□1

JXC7303/92/93

LEY

AC Servo Motor
LEYG

LECS□

LECS-T

LECY□

Specific Product
Precautions

Series LECP6

Series LECA6

Option: I/O Cable

LEC-CN5-1

Cable length (L) [m]

1	1.5
3	3
5	5

* Conductor size: AWG28

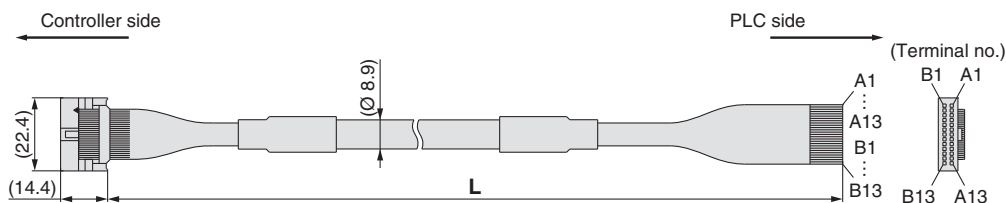

Connector pin no.	Insulation colour	Dot mark	Dot colour
A1	Light brown	■	Black
A2	Light brown	■	Red
A3	Yellow	■	Black
A4	Yellow	■	Red
A5	Light green	■	Black
A6	Light green	■	Red
A7	Grey	■	Black
A8	Grey	■	Red
A9	White	■	Black
A10	White	■	Red
A11	Light brown	■ ■	Black
A12	Light brown	■ ■	Red
A13	Yellow	■ ■	Black

Connector pin no.	Insulation colour	Dot mark	Dot colour
B1	Yellow	■ ■	Red
B2	Light green	■ ■	Black
B3	Light green	■ ■	Red
B4	Grey	■ ■	Black
B5	Grey	■ ■	Red
B6	White	■ ■	Black
B7	White	■ ■	Red
B8	Light brown	■ ■ ■	Black
B9	Light brown	■ ■ ■	Red
B10	Yellow	■ ■ ■	Black
B11	Yellow	■ ■ ■	Red
B12	Light green	■ ■ ■	Black
B13	Light green	■ ■ ■	Red
—	Shield		

Option: Noise Filter Set for Servo Motor (24 VDC)

LEC-NFA

Contents of the set: 2 noise filters (Manufactured by WURTH ELEKTRONIK: 74271222)

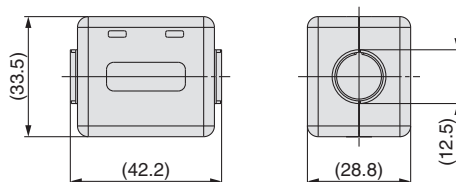

* Refer to the LECA6 series Operation Manual for installation.

Series **LEC**

Windows®XP, Windows®7 compatible

Controller Setting Kit/LEC-W2

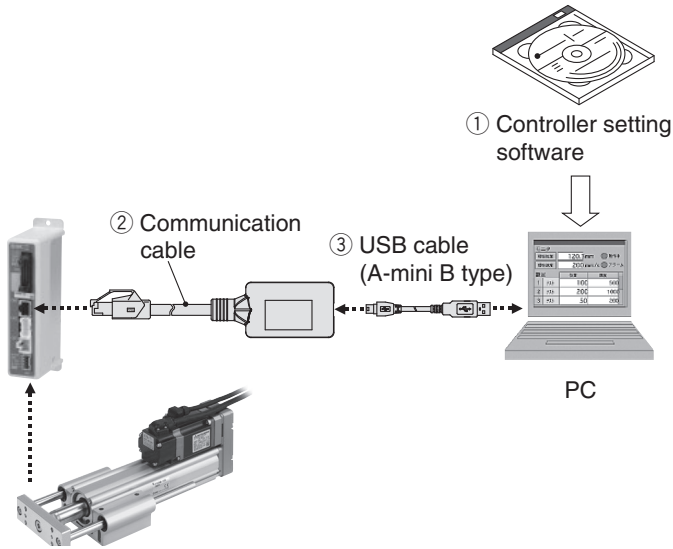

How to Order

LEC-W2

Controller setting kit
(Japanese and English are available.)

Contents

	Description	Model*
①	Controller setting software (CD-ROM)	LEC-W2-S
②	Communication cable	LEC-W2-C
③	USB cable (between the PC and the communication cable)	LEC-W2-U

* Can be ordered separately.

Compatible Controller/Driver

Step data input type
Pulse input type

Series **LECP6**/Series **LECA6**
Series **LECPA**

Hardware Requirements

OS	IBM PC/AT compatible machine running Windows®XP (32-bit), Windows®7 (32-bit and 64-bit), Windows®8.1 (32-bit and 64-bit).
Communication interface	USB 1.1 or USB 2.0 ports
Display	XGA (1024 x 768) or more

* Windows®XP, Windows®7 and Windows®8.1 are registered trademarks of Microsoft Corporation in the United States.
* Refer to SMC website for version upgrade information, <http://www.smc.eu>

Screen Example

Easy mode screen example

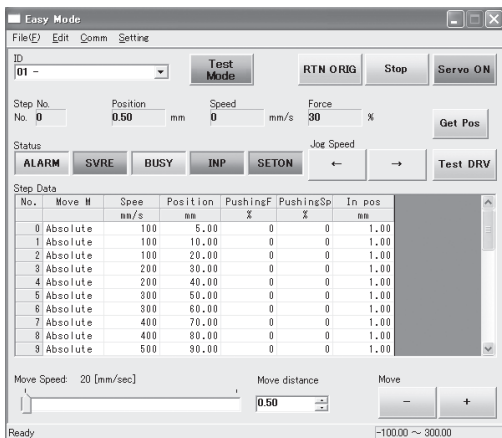

Easy operation and simple setting

- Allowing to set and display actuator step data such as position, speed, force, etc.
- Setting of step data and testing of the drive can be performed on the same page.
- Can be used to jog and move at a constant rate.

Normal mode screen example

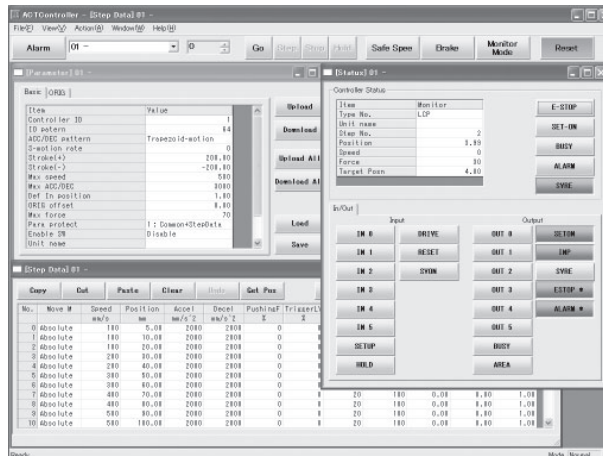

Detailed setting

- Step data can be set in detail.
- Signals and terminal status can be monitored.
- Parameters can be set.
- JOG and constant rate movement, return to origin, test operation and testing of forced output can be performed.

Model Selection

Servo Motor (24 VDC)/Step Motor (Servo/24 VDC)

LEY

LEYG

LECA6
LECP6

LEC-G

LECP1

LECPA

JXC□1

JXC7303/92/93

LEY

AC Servo Motor

LEYG

LECS

LECS-T

LECY

Specific Product Precautions

Series LEC Teaching Box/LEC-T1



How to Order

LEC-T1-3EG

Teaching box

Cable length [m]
3 3

Initial language

J	Japanese
E	English

Enable switch

—	None
S	Equipped with enable switch

* Interlock switch for jog and test function

Stop switch

G	Equipped with stop switch
---	---------------------------

* The displayed language can be changed to English or Japanese.

Standard functions

- Chinese character display
- Stop switch is provided.

Option

- Enable switch is provided.

Specifications

Item	Description
Switch	Stop switch, Enable switch (Option)
Cable length [m]	3
Enclosure	IP64 (Except connector)
Operating temperature range [°C]	5 to 50
Operating humidity range [%RH]	90 or less (No condensation)
Weight [g]	350 (Except cable)

[CE-compliant products]

The EMC compliance of the teaching box was tested with the LECPE6 series step motor controller (servo/24 VDC) and an applicable actuator.

[UL-compliant products]

When conformity to UL is required, the electric actuator and controller should be used with a UL1310 Class 2 power supply.

Easy Mode

Function	Details
Step data	• Setting of step data
Jog	• Jog operation • Return to origin
Test	• 1 step operation • Return to origin
Monitor	• Display of axis and step data no. • Display of two items selected from Position, Speed, Force.
ALM	• Active alarm display • Alarm reset
TB setting	• Reconnection of axis (Ver. 1.**) • Displayed language setting (Ver. 2.**) • Setting of easy/normal mode • Setting step data and selection of items from easy mode monitor

Menu Operations Flowchart

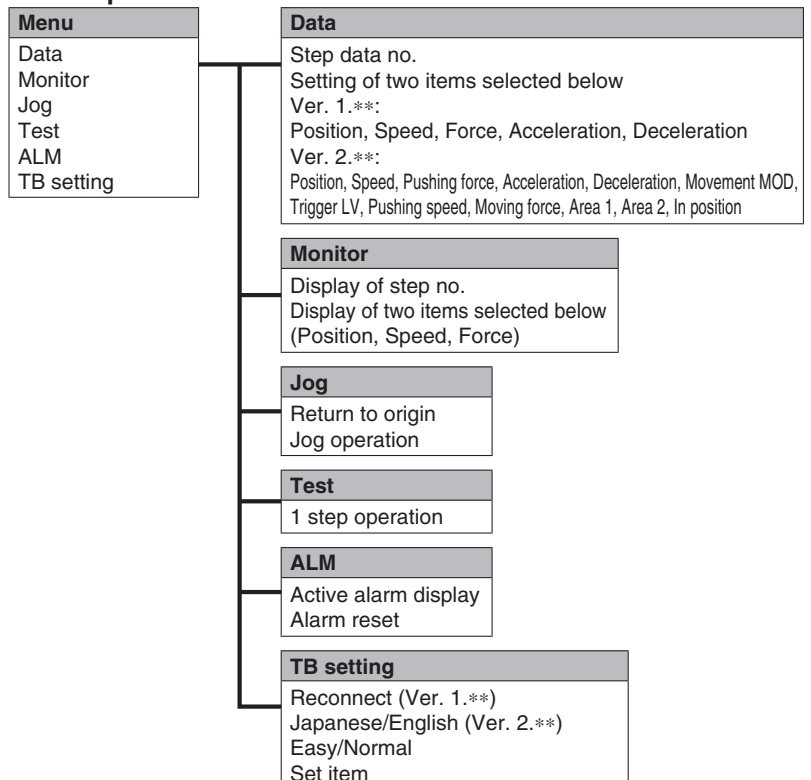

Normal Mode

Function	Details
Step data	• Step data setting
Parameter	• Parameters setting
Test	<ul style="list-style-type: none"> • Jog operation/Constant rate movement • Return to origin • Test drive (Specify a maximum of 5 step data and operate.) • Forced output (Forced signal output, Forced terminal output)
Monitor	<ul style="list-style-type: none"> • Drive monitor • Output signal monitor • Input signal monitor • Output terminal monitor • Input terminal monitor
ALM	<ul style="list-style-type: none"> • Active alarm display (Alarm reset) • Alarm log record display
File	<ul style="list-style-type: none"> • Data saving Save the step data and parameters of the controller which is being used for communication (it is possible to save four files, with one set of step data and parameters defined as one file). • Load to controller Loads the data which is saved in the teaching box to the controller which is being used for communication. • Delete the saved data. • File protection (Ver. 2.**)
TB setting	<ul style="list-style-type: none"> • Display setting (Easy/Normal mode) • Language setting (Japanese/English) • Backlight setting • LCD contrast setting • Beep sound setting • Max. connection axis • Distance unit (mm/inch)
Reconnect	• Reconnection of axis

Menu Operations Flowchart

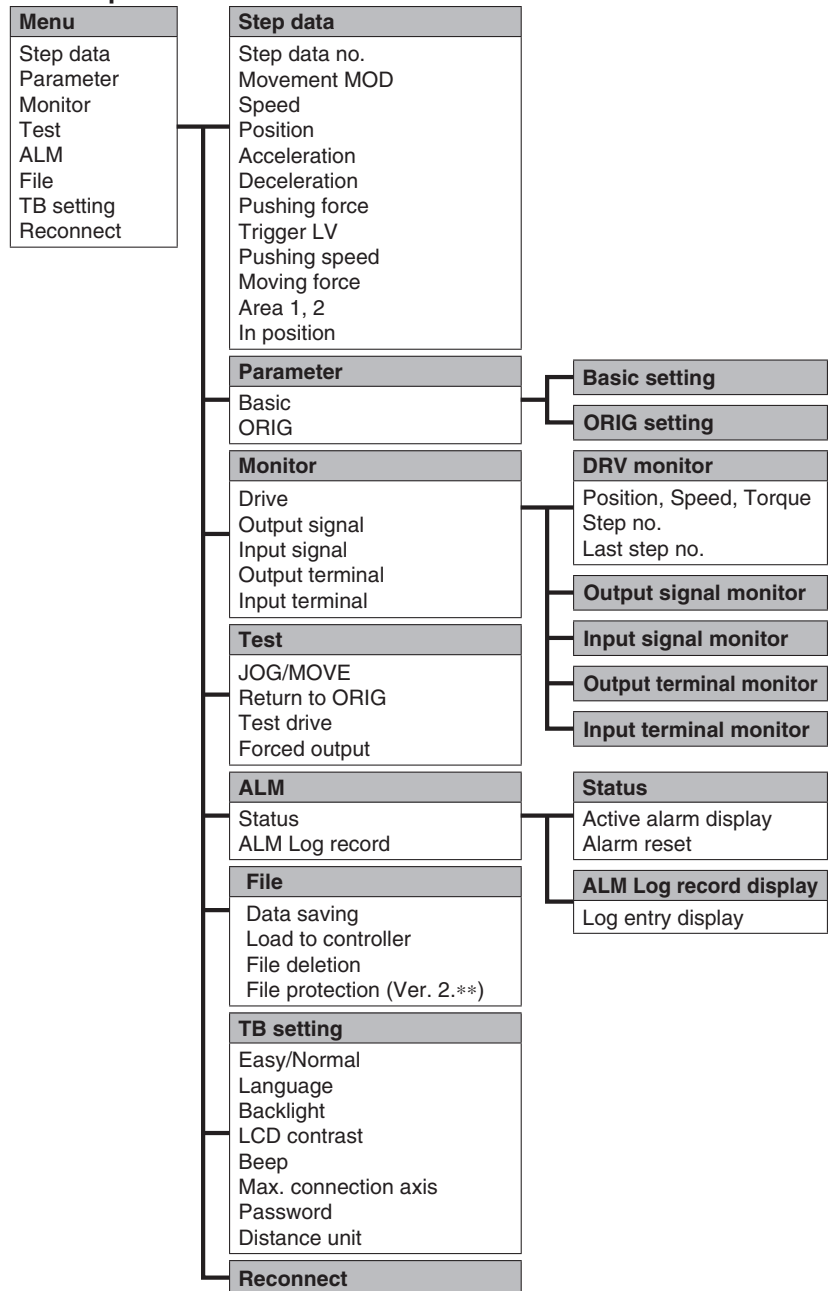

Dimensions

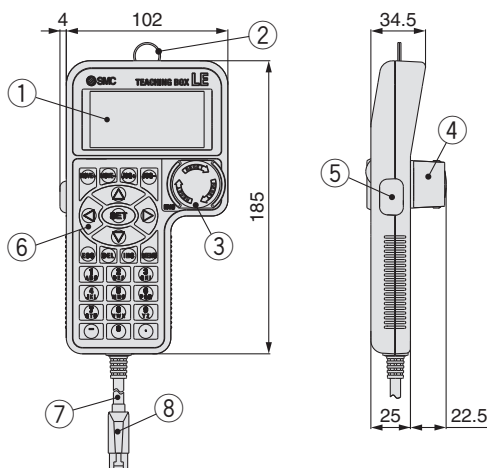

No.	Description	Function
1	LCD	A screen of liquid crystal display (with backlight)
2	Ring	A ring for hanging the teaching box
3	Stop switch	When switch is pushed in, the switch locks and stops. The lock is released when it is turned to the right.
4	Stop switch guard	A guard for the stop switch
5	Enable switch (Option)	Prevents unintentional operation (unexpected operation) of the jog test function. Other functions such as data change are not covered.
6	Key switch	Switch for each input
7	Cable	Length: 3 meters
8	Connector	A connector connected to CN4 of the controller

Model Selection
 Servo Motor (24 VDC) / Step Motor (Servo/24 VDC)
 LECAG LECPC6
 LEC-G
 LECPC1
 LECPA
 JXC□1
 JXC7□□□□□□□□
 AC Servo Motor
 LEY
 LEYG
 LECS□
 LECS-T
 LECY□
 Specific Product Precautions

Gateway Unit Series LEC-G



How to Order

⚠ Caution
[CE-compliant products]
 EMC compliance was tested by combining the electric actuator LE series and the controller LEC series. The EMC depends on the configuration of the customer's control panel and the relationship with other electrical equipment and wiring. Therefore, conformity to the EMC directive cannot be certified for SMC components incorporated into the customer's equipment under actual operating conditions. As a result, it is necessary for the customer to verify conformity to the EMC directive for the machinery and equipment as a whole.
[UL-compliant products]
 When conformity to UL is required, the electric actuator and controller should be used with a UL1310 Class 2 power supply.

Gateway unit LEC-G MJ2

Applicable Fieldbus protocols

MJ2	CC-Link Ver. 2.0
DN1	DeviceNet™
PR1	PROFIBUS DP
EN1	EtherNet/IP™

Mounting

—	Screw mounting
D (Note)	DIN rail mounting

Note) DIN rail is not included.
Order it separately.



Cable LEC-CG 1-L

Cable type

1	Communication cable
2	Cable between branches

Cable length

K	0.3 m
L	0.5 m
1	1 m

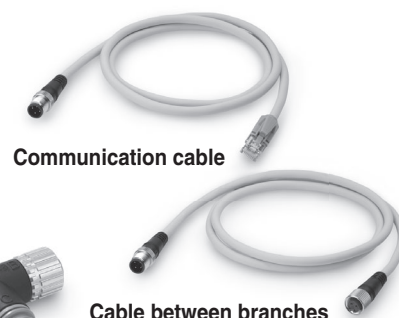

Branch connector LEC-CGD

Branch connector



Terminating resistor LEC-CGR

Specifications

Model		LEC-GMJ2□	LEC-GDN1□	LEC-GPR1□	LEC-GEN1□		
Communication specifications	Applicable system	Fieldbus	CC-Link	DeviceNet™	PROFIBUS DP		
		Version (Note 1)	Ver. 2.0	Release 2.0	V1		
	Communication speed [bps]		156 k/625 k/2.5 M /5 M/10 M	125 k/250 k/500 k	9.6 k/19.2 k/45.45 k/ 93.75 k/187.5 k/500 k/ 1.5 M/3 M/6 M/12 M	10 M/100 M	
	Configuration file (Note 2)		—	EDS file	GSD file	EDS file	
	I/O occupation area		4 stations occupied (8 times setting)	Input 896 points 108 words Output 896 points 108 words	Input 200 bytes Output 200 bytes	Input 57 words Output 57 words	Input 256 bytes Output 256 bytes
	Power supply for communication	Power supply voltage [V] (Note 5)	—	11 to 25 VDC	—	—	
		Internal current consumption [mA]	—	100	—	—	
	Communication connector specifications		Connector (Accessory)	Connector (Accessory)	D-sub	RJ45	
Terminating resistor		Not included	Not included	Not included	Not included		
Power supply voltage [V] (Note 6)		24 VDC ±10 %					
Current consumption [mA]	Not connected to teaching box	200					
	Connected to teaching box	300					
EMG output terminal		30 VDC 1 A					
Controller specifications	Applicable controllers	Series LECP6, Series LECA6					
	Communication speed [bps] (Note 3)	115.2 k/230.4 k					
	Max. number of connectable controllers (Note 4)	12	8 (Note 5)	5	12		
Accessories		Power supply connector, communication connector		Power supply connector			
Operating temperature range [°C]		0 to 40 (No freezing)					
Operating humidity range [%RH]		90 or less (No condensation)					
Storage temperature range [°C]		-10 to 60 (No freezing)					
Storage humidity range [%RH]		90 or less (No condensation)					
Weight [g]		200 (Screw mounting), 220 (DIN rail mounting)					

Note 1) Please note that the version is subject to change.

Note 2) Each file can be downloaded from the SMC website, <http://www.smc.eu>

Note 3) When using a teaching box (LEC-T1-□), set the communication speed to 115.2 kbps.

Note 4) A communication response time for 1 controller is approximately 30 ms.

Refer to "Communication Response Time Guideline" for response times when several controllers are connected.

Note 5) For step data input, up to 12 controllers connectable.

Note 6) When conformity to UL is required, the electric actuator and controller should be used with a UL1310 Class 2 power supply.

Communication Response Time Guideline

Response time between gateway unit and controllers depends on the number of controllers connected to the gateway unit. For response time, refer to the graph below.

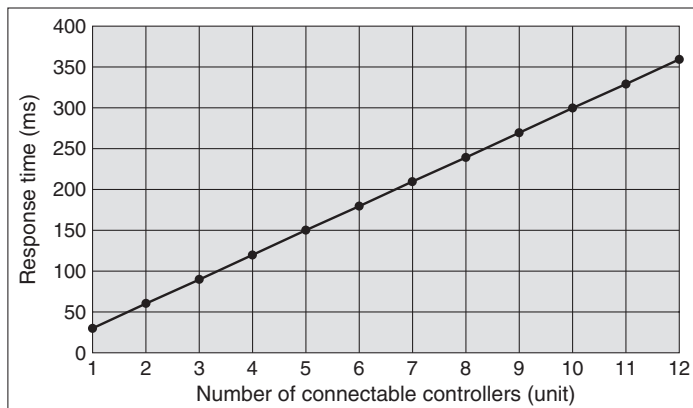

* This graph shows delay times between gateway unit and controllers. Fieldbus network delay time is not included.

Dimensions

Screw mounting (LEC-G□□□)

Applicable Fieldbus protocol: CC-Link Ver. 2.0

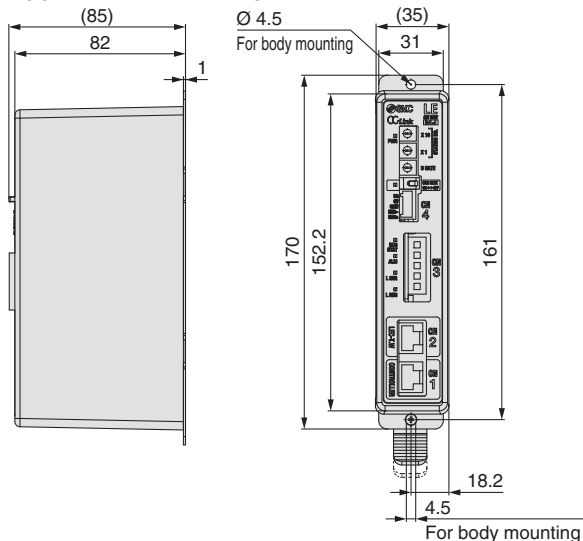

Applicable Fieldbus protocol: DeviceNet™

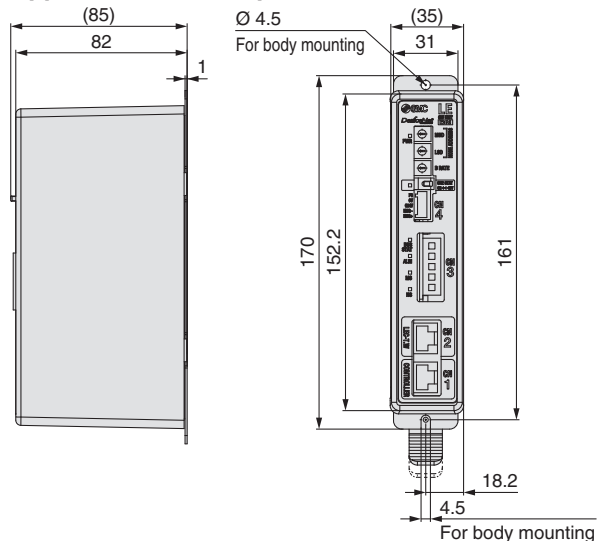

Applicable Fieldbus protocol: PROFIBUS DP

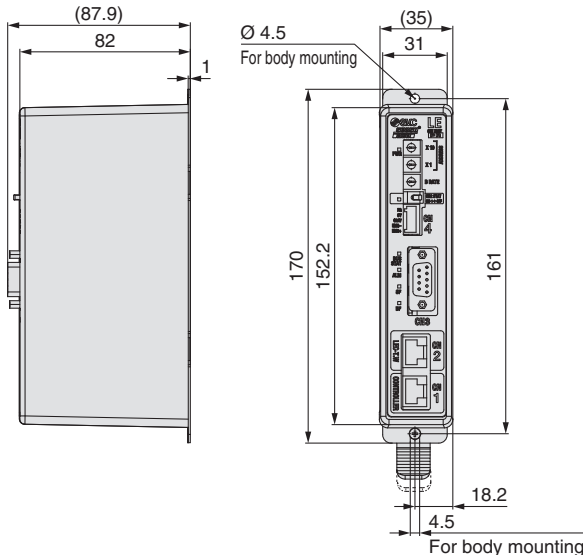

Applicable Fieldbus protocol: EtherNet/IP™

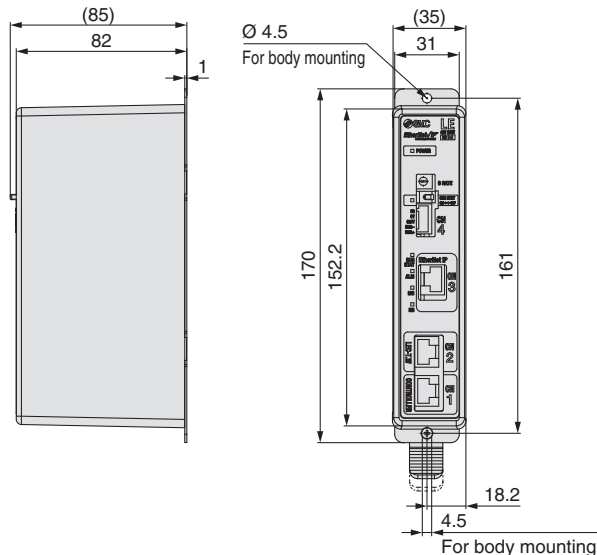

■ Trademark DeviceNet™ is a trademark of ODVA. EtherNet/IP™ is a trademark of ODVA.

Model Selection	LEY
Servo Motor (24 VDC)/Step Motor (Servo/24 VDC)	LEYG
LEC-G	LEC-G
LECA6 LECP6	LECP1
LECPA	JXC□1
JXC7□□□□□□	JXC7□□□□□□
AC Servo Motor	LEY
LEYG	LEYG
LECS□	LECS-T
LECY□	LECY□
Specific Product Precautions	

Series LEC-G

Dimensions

DIN rail mounting (LEC-G□□□D)

Applicable Fieldbus protocol: CC-Link Ver. 2.0

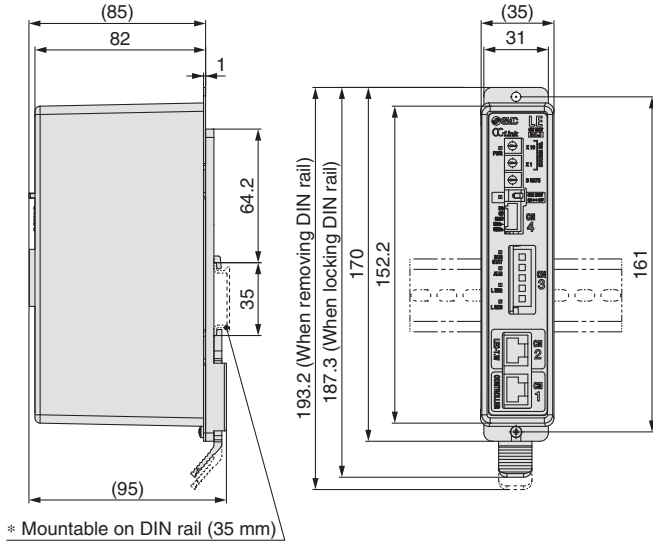

Applicable Fieldbus protocol: DeviceNet™

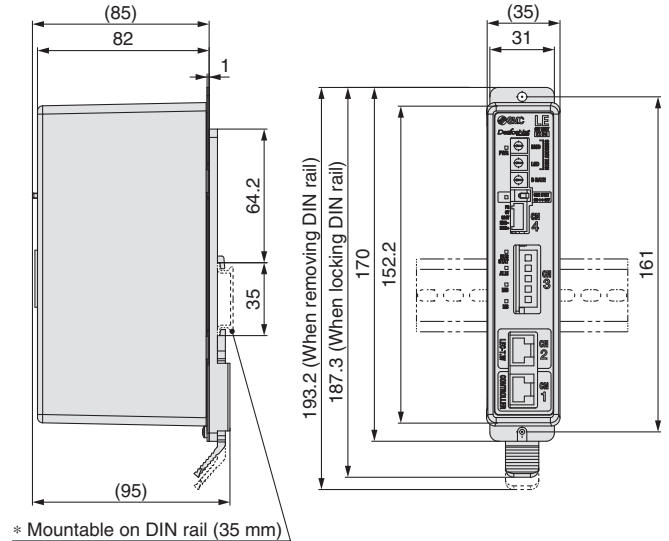

Applicable Fieldbus protocol: PROFIBUS DP

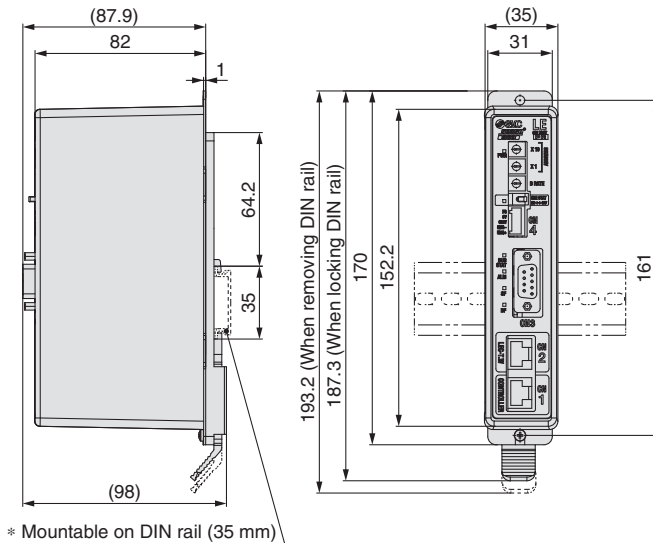

Applicable Fieldbus protocol: EtherNet/IP™

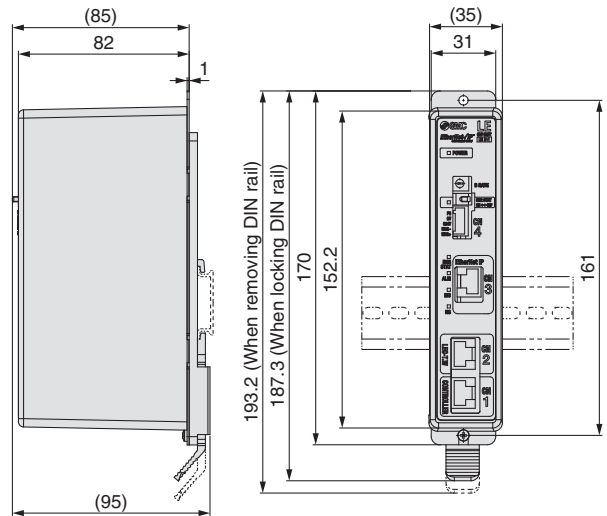

DIN rail

AXT100-DR-□

* For □, enter a number from the "No." line in the table below. Refer to the dimensions above for the mounting dimensions.

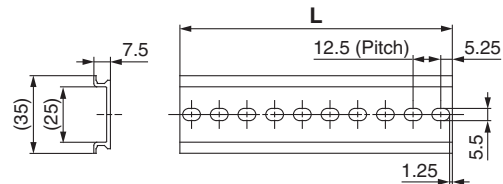

L Dimension [mm]

No.	1	2	3	4	5	6	7	8	9	10	11	12	13	14	15	16	17	18	19	20
L	23	35.5	48	60.5	73	85.5	98	110.5	123	135.5	148	160.5	173	185.5	198	210.5	223	235.5	248	260.5
No.	21	22	23	24	25	26	27	28	29	30	31	32	33	34	35	36	37	38	39	40
L	273	285.5	298	310.5	323	335.5	348	360.5	373	385.5	398	410.5	423	435.5	448	460.5	473	485.5	498	510.5

■ Trademark DeviceNet™ is a trademark of ODVA. EtherNet/IP™ is a trademark of ODVA.

Programless Controller Series *LECP1*



How to Order

LECP1 P 1 [] - LEY16B-100

- Controller**
- Compatible motor**
 - P** Step motor (Servo/24 VDC)
- Number of step data (Points)**
 - 1** 14 (Programless)
- Parallel I/O type**
 - N** NPN
 - P** PNP
- Option**
 - Screw mounting
 - D (Note)** DIN rail mounting

Note) DIN rail is not included. Order it separately.
- I/O cable length [m]**
 - Without cable
 - 1** 1.5
 - 3** 3
 - 5** 5
- Actuator part number**

(Except cable specification and actuator options)
Example: Enter "LEY16B-100" for the LEY16B-100B-R11N1.

* When controller equipped type (-□1N□/-□1P□) is selected when ordering the LE series, you do not need to order this controller.

⚠ Caution
[CE-compliant products]
 EMC compliance was tested by combining the electric actuator LEF series and the controller LEC series. The EMC depends on the configuration of the customer's control panel and the relationship with other electrical equipment and wiring. Therefore, conformity to the EMC directive cannot be certified for SMC components incorporated into the customer's equipment under actual operating conditions. As a result, it is necessary for the customer to verify conformity to the EMC directive for the machinery and equipment as a whole.
[UL-compliant products]
 When conformity to UL is required, the electric actuator and controller should be used with a UL1310 Class 2 power supply.

The controller is sold as single unit after the compatible actuator is set.
 Confirm that the combination of the controller and the actuator is correct.
 * Refer to the Operation Manual for using the products. Please download it via our website, <http://www.smc.eu>

Specifications

Basic Specifications

Item	LECP1
Compatible motor	Step motor (Servo/24 VDC)
Power supply <small>Note 1)</small>	Power supply voltage: 24 VDC ±10 %, Max. current consumption: 3A (Peak 5A) <small>Note 2)</small> [Including the motor drive power, control power supply, stop, lock release]
Parallel input	6 inputs (Photo-coupler isolation)
Parallel output	6 outputs (Photo-coupler isolation)
Stop points	14 points (Position number 1 to 14(E))
Compatible encoder	Incremental A/B phase (800 pulse/rotation)
Memory	EEPROM
LED indicator	LED (Green/Red) one of each
7-segment LED display <small>Note 3)</small>	1 digit, 7-segment display (Red) Figures are expressed in hexadecimal ("10" to "15" in decimal number are expressed as "A" to "F")
Lock control	Forced-lock release terminal <small>Note 4)</small>
Cable length [m]	I/O cable: 5 or less, Actuator cable: 20 or less
Cooling system	Natural air cooling
Operating temperature range [°C]	0 to 40 (No freezing)
Operating humidity range [%RH]	90 or less (No condensation)
Storage temperature range [°C]	-10 to 60 (No freezing)
Storage humidity range [%RH]	90 or less (No condensation)
Insulation resistance [MΩ]	Between the housing and SG terminal: 50 (500 VDC)
Weight [g]	130 (Screw mounting), 150 (DIN rail mounting)

Note 1) Do not use the power supply of "inrush current prevention type" for the controller input power supply. When conformity to UL is required, the electric actuator and controller should be used with a UL1310 Class 2 power supply.

Note 2) The power consumption changes depending on the actuator model. Refer to the each actuator's operation manual etc. for details.

Note 3) "10" to "15" in decimal number are displayed as follows in the 7-segment LED.



Decimal display 10 11 12 13 14 15
 Hexadecimal display A b c d E F

Note 4) Applicable to non-magnetizing lock.

Model Selection

LEY

LEYG

LECA6
LECP6

LEC-G

LECP1

LECPA

JXC□1

JXC73/83/92/93

LEY

LEYG

LECS□

LECS-T

LECY□

Specific Product Precautions

Series LECP1

Controller Details

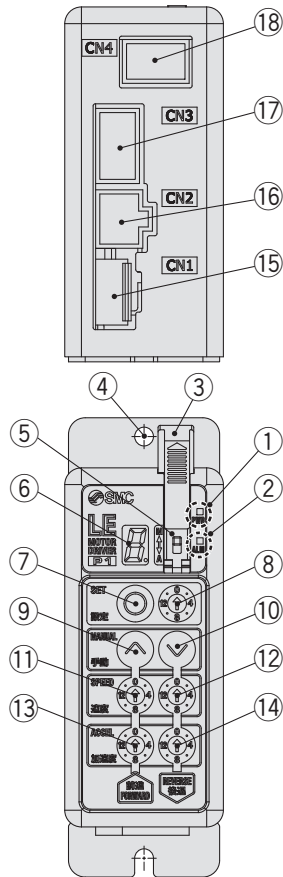

No.	Display	Description	Details
①	PWR	Power supply LED	Power supply ON/Servo ON : Green turns on Power supply ON/Servo OFF: Green flashes
②	ALM	Alarm LED	With alarm : Red turns on Parameter setting : Red flashes
③	—	Cover	Change and protection of the mode switch (Close the cover after changing switch)
④	—	FG	Frame ground (Tighten the bolt with the nut when mounting the controller. Connect the ground wire.)
⑤	—	Mode switch	Switch the mode between manual and auto.
⑥	—	7-segment LED	Stop position, the value set by ⑧ and alarm information are displayed.
⑦	SET	Set button	Decide the settings or drive operation in Manual mode.
⑧	—	Position selecting switch	Assign the position to drive (1 to 14), and the origin position (15).
⑨	MANUAL	Manual forward button	Perform forward jog and inching.
⑩		Manual reverse button	Perform reverse jog and inching.
⑪	SPEED	Forward speed switch	16 forward speeds are available.
⑫		Reverse speed switch	16 reverse speeds are available.
⑬	ACCEL	Forward acceleration switch	16 forward acceleration steps are available.
⑭		Reverse acceleration switch	16 reverse acceleration steps are available.
⑮	CN1	Power supply connector	Connect the power supply cable.
⑯	CN2	Motor connector	Connect the motor connector.
⑰	CN3	Encoder connector	Connect the encoder connector.
⑱	CN4	I/O connector	Connect I/O cable.

How to Mount

Controller mounting shown below.

1. Mounting screw (LECP1□□-□)

(Installation with two M4 screws)

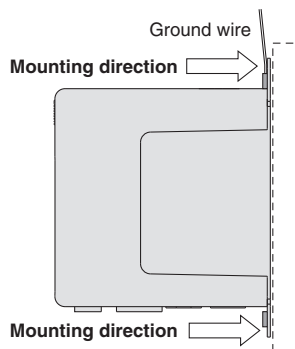

2. Grounding

Tighten the bolt with the nut when mounting the ground wire as shown below.

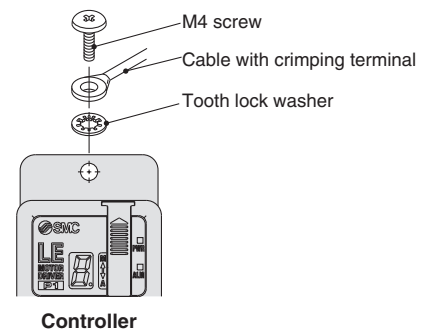

Note) When size 25 or more of the LE series are used, the space between the controllers should be 10 mm or more.

⚠ Caution

- M4 screws, cable with crimping terminal and tooth lock washer are not included. Be sure to carry out grounding earth in order to ensure the noise tolerance.
- Use a watchmaker's screwdriver of the size shown below when changing position switch ⑧ and the set value of the speed/acceleration switch ⑪ to ⑭.

Size

End width **L**: 2.0 to 2.4 [mm]
End thickness **W**: 0.5 to 0.6 [mm]

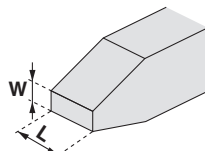

Magnified view of the end of the screwdriver

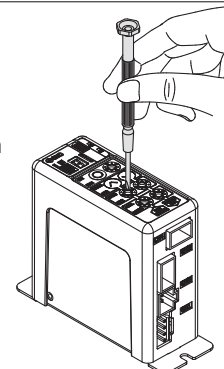

Dimensions

DIN rail mounting (LEC□1□□D-□)

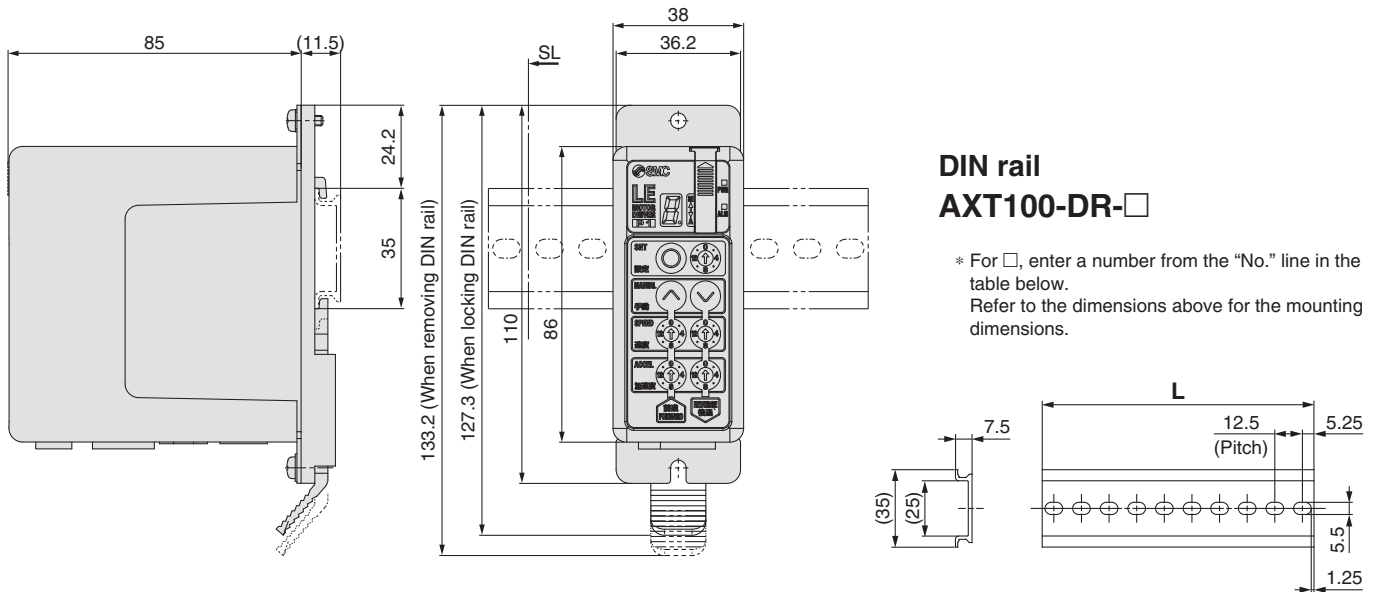

L Dimension [mm]

No.	1	2	3	4	5	6	7	8	9	10	11	12	13	14	15	16	17	18	19	20	21
L	23	35.5	48	60.5	73	85.5	98	110.5	123	135.5	148	160.5	173	185.5	198	210.5	223	235.5	248	260.5	273
No.	22	23	24	25	26	27	28	29	30	31	32	33	34	35	36	37	38	39	40		
L	285.5	298	310.5	323	335.5	348	360.5	373	385.5	398	410.5	423	435.5	448	460.5	473	485.5	498	510.5		

DIN rail mounting adapter

LEC-1-D0 (with 2 mounting screws)

This should be used when the DIN rail mounting adapter is mounted onto the screw mounting type controller afterwards.

Screw mounting (LEC□1□□-□)

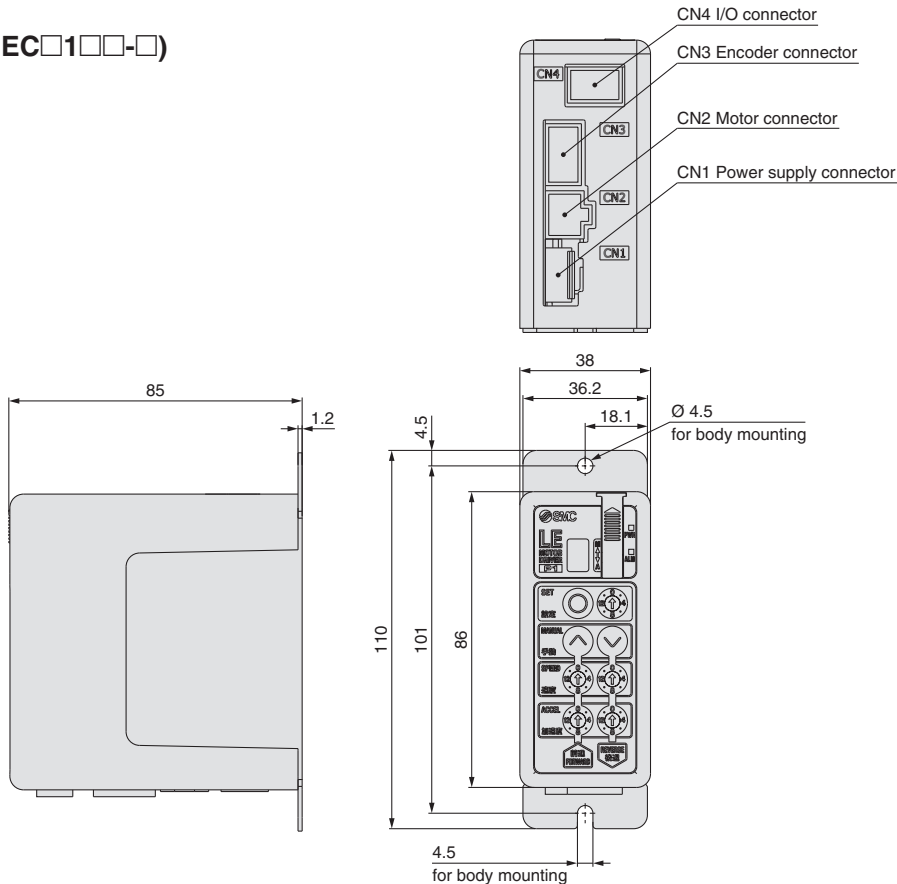

Model Selection

LECY

LEYG

LECA6
LECP6

LEC-G

LECP1

LECPA

JXC□1

JXC7303/92/93

LEY

LEYG

LECS□

LECS-T

LECY□

Specific Product Precautions

AC Servo Motor

82

Series LECP1

Wiring Example 1

Power Supply Connector: CN1 * When you connect a CN1 power supply connector, use the power supply cable (LEC-CK1-1).
* Power supply cable (LEC-CK1-1) is an accessory.

CN1 Power Supply Connector Terminal for LECP1

Terminal name	Cable colour	Function	Details
0V	Blue	Common supply (-)	M 24V terminal/C 24V terminal/BK RLS terminal are common (-).
M 24V	White	Motor power supply (+)	Motor power supply (+) supplied to the controller
C 24V	Brown	Control power supply (+)	Control power supply (+) supplied to the controller
BK RLS	Black	Lock release (+)	Input (+) for releasing the lock

Power supply cable for LECP1 (LEC-CK1-1)

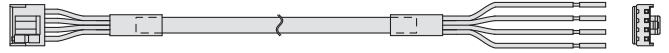

Wiring Example 2

Parallel I/O Connector: CN4 * When you connect a PLC etc., to the CN4 parallel I/O connector, use the I/O cable (LEC-CK4-□).
* The wiring should be changed depending on the type of the parallel I/O (NPN or PNP).

■ NPN

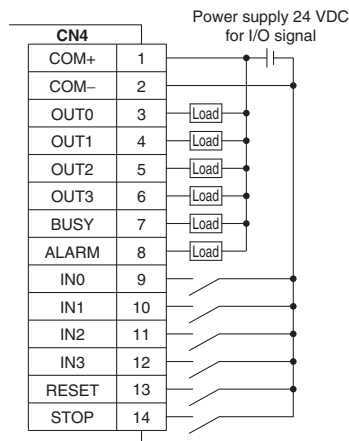

■ PNP

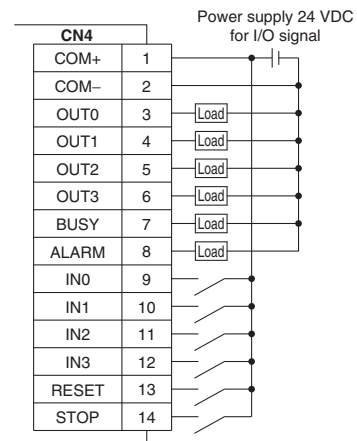

Input Signal

Name	Details								
COM+	Connects the power supply 24 V for input/output signal								
COM-	Connects the power supply 0 V for input/output signal								
IN0 to IN3	<ul style="list-style-type: none"> Instruction to drive (input as a combination of IN0 to IN3) Instruction to return to origin (IN0 to IN3 all ON simultaneously) Example - (instruction to drive for position no. 5) <table border="1" style="margin-left: 20px;"> <thead> <tr> <th>IN3</th> <th>IN2</th> <th>IN1</th> <th>IN0</th> </tr> </thead> <tbody> <tr> <td>OFF</td> <td>ON</td> <td>OFF</td> <td>ON</td> </tr> </tbody> </table>	IN3	IN2	IN1	IN0	OFF	ON	OFF	ON
IN3	IN2	IN1	IN0						
OFF	ON	OFF	ON						
RESET	Alarm reset and operation interruption During operation: deceleration stop from position at which signal is input (servo ON maintained) While alarm is active: alarm reset								
STOP	Instruction to stop (after maximum deceleration stop, servo OFF)								

Output Signal

Name	Details								
OUT0 to OUT3	Turns on when the positioning or pushing is completed. (Output is instructed in the combination of OUT0 to 3.) Example - (operation complete for position no. 3) <table border="1" style="margin-left: 20px;"> <thead> <tr> <th>OUT3</th> <th>OUT2</th> <th>OUT1</th> <th>OUT0</th> </tr> </thead> <tbody> <tr> <td>OFF</td> <td>OFF</td> <td>ON</td> <td>ON</td> </tr> </tbody> </table>	OUT3	OUT2	OUT1	OUT0	OFF	OFF	ON	ON
OUT3	OUT2	OUT1	OUT0						
OFF	OFF	ON	ON						
BUSY	Outputs when the actuator is moving								
*ALARM (Note)	Not output when alarm is active or servo OFF								

Note) Signal of negative-logic circuit (N.C.)

Input Signal [IN0 - IN3] Position Number Chart ○: OFF ●: ON

Position number	IN3	IN2	IN1	IN0
1	○	○	○	●
2	○	○	●	○
3	○	○	●	●
4	○	●	○	○
5	○	●	○	●
6	○	●	●	○
7	○	●	●	●
8	●	○	○	○
9	●	○	○	●
10 (A)	●	○	●	○
11 (B)	●	○	●	●
12 (C)	●	●	○	○
13 (D)	●	●	○	●
14 (E)	●	●	●	○
Return to origin	●	●	●	●

Output Signal [OUT0 - OUT3] Position Number Chart ○: OFF ●: ON

Position number	OUT3	OUT2	OUT1	OUT0
1	○	○	○	●
2	○	○	●	○
3	○	○	●	●
4	○	●	○	○
5	○	●	○	●
6	○	●	●	○
7	○	●	●	●
8	●	○	○	○
9	●	○	○	●
10 (A)	●	○	●	○
11 (B)	●	○	●	●
12 (C)	●	●	○	○
13 (D)	●	●	○	●
14 (E)	●	●	●	○
Return to origin	●	●	●	●

Signal Timing

(1) Return to Origin

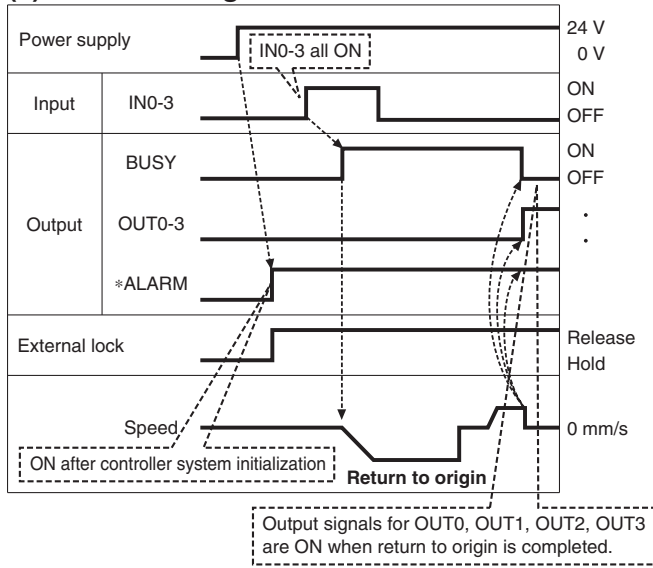

*"ALARM" is expressed as negative-logic circuit.

(2) Positioning Operation

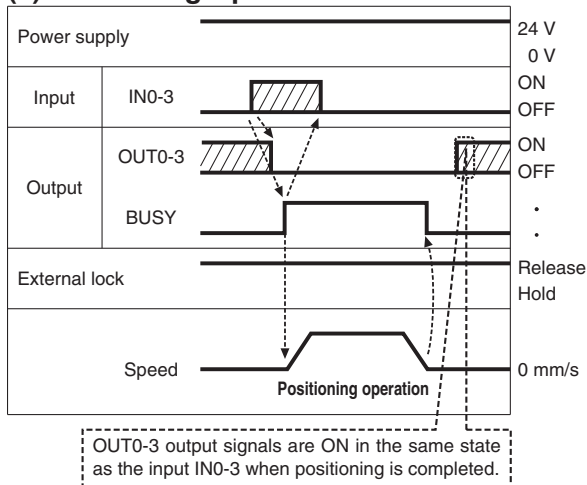

(4) Stop by the STOP Signal

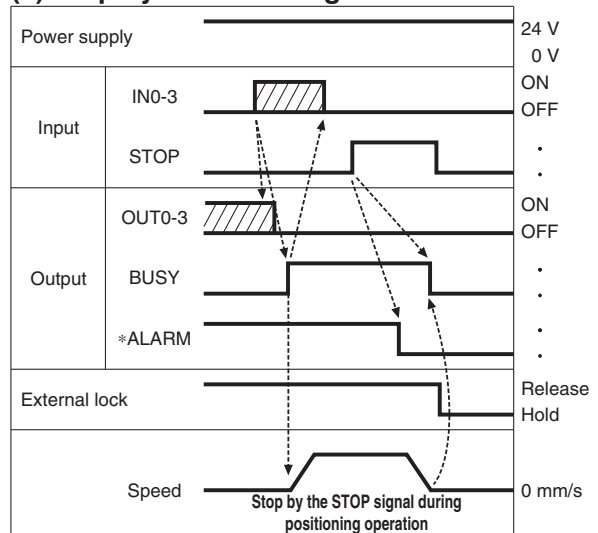

(3) Cut-off Stop (Reset Stop)

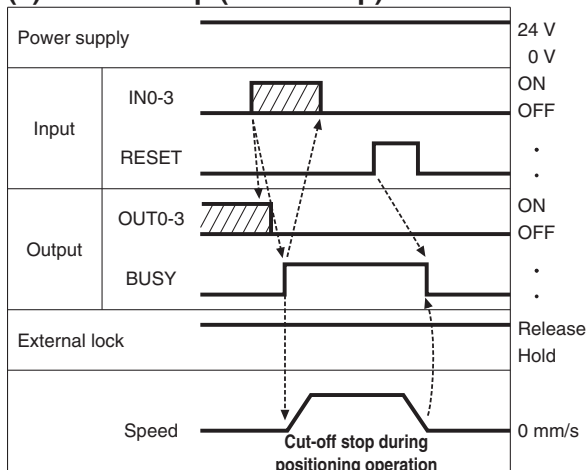

(5) Alarm Reset

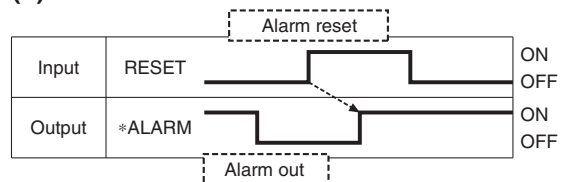

*"ALARM" is expressed as negative-logic circuit.

Model Selection

LEY

LEYG

LECA6
LECP6

LEC-G

LECP1

LECPA

JXC□1

JXC7□□□□□□□□

LEY

LEYG

LECS□

LECS-T

LECY□

Specific Product Precautions

Series LECP1

Options: Actuator Cable

[Robotic cable, standard cable for step motor (Servo/24 VDC)]

LE-CP-1-

Cable length (L) [m]

1	1.5
3	3
5	5
8	8*
A	10*
B	15*
C	20*

* Produced upon receipt of order (Robotic cable only)

Cable type

-	Robotic cable (Flexible cable)
S	Standard cable

LE-CP-¹/₃/Cable length: 1.5 m, 3 m, 5 m

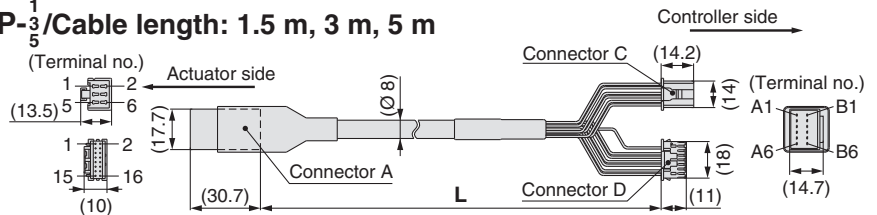

LE-CP-⁸/_{AC}^B/Cable length: 8 m, 10 m, 15 m, 20 m
(* Produced upon receipt of order)

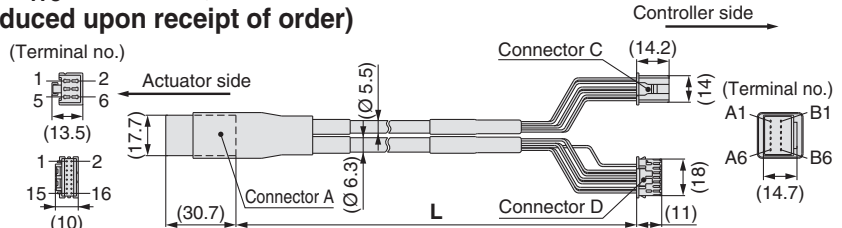

Signal	Connector A terminal no.	Cable colour	Connector C terminal no.
A	B-1	Brown	2
A	A-1	Red	1
B	B-2	Orange	6
B	A-2	Yellow	5
COM-A/COM	B-3	Green	3
COM-B/-	A-3	Blue	4
Shield			
Vcc	B-4	Brown	12
GND	A-4	Black	13
A	B-5	Red	7
A	A-5	Black	6
B	B-6	Orange	9
B	A-6	Black	8
			3

[Robotic cable, standard cable with lock and sensor for step motor (Servo/24 VDC)]

LE-CP-1-B-

Cable length (L) [m]

1	1.5
3	3
5	5
8	8*
A	10*
B	15*
C	20*

* Produced upon receipt of order (Robotic cable only)

With lock and sensor

Cable type

-	Robotic cable (Flexible cable)
S	Standard cable

LE-CP-¹/₃/Cable length: 1.5 m, 3 m, 5 m

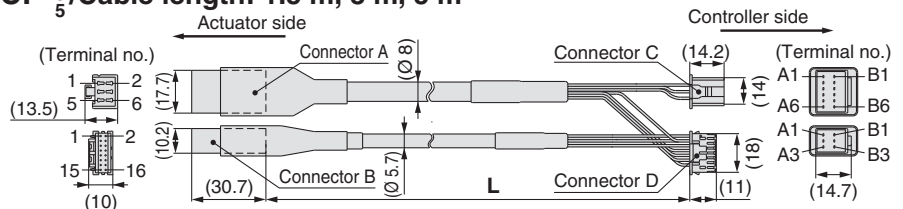

LE-CP-⁸/_{AC}^B/Cable length: 8 m, 10 m, 15 m, 20 m
(* Produced upon receipt of order)

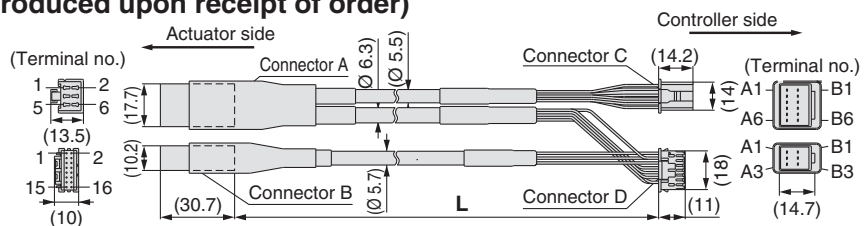

Signal	Connector A terminal no.	Cable colour	Connector C terminal no.
A	B-1	Brown	2
A	A-1	Red	1
B	B-2	Orange	6
B	A-2	Yellow	5
COM-A/COM	B-3	Green	3
COM-B/-	A-3	Blue	4
Shield			
Vcc	B-4	Brown	12
GND	A-4	Black	13
A	B-5	Red	7
A	A-5	Black	6
B	B-6	Orange	9
B	A-6	Black	8
			3

Signal	Connector B terminal no.	Cable colour	Connector D terminal no.
Lock (+)	B-1	Red	4
Lock (-)	A-1	Black	5
Sensor (+) (Note)	B-3	Brown	1
Sensor (-) (Note)	A-3	Blue	2

Options

[Power supply cable]

LEC-CK1-1

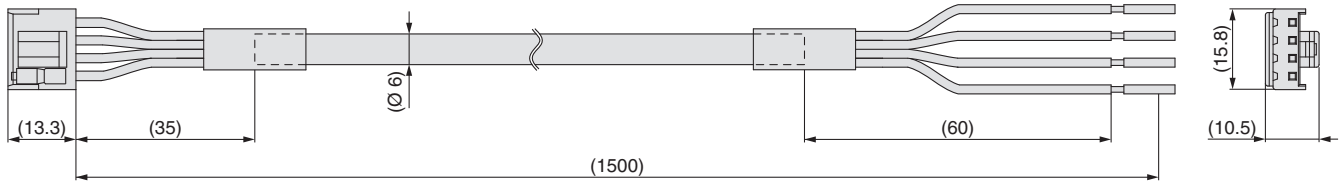

Terminal name	Covered colour	Function
0V	Blue	Common supply (-)
M 24V	White	Motor power supply (+)
C 24V	Brown	Control power supply (+)
BK RLS	Black	Lock release (+)

* Conductor size: AWG20

[I/O cable]

LEC-CK4-

Cable length (L) [m]

1	1.5
3	3
5	5

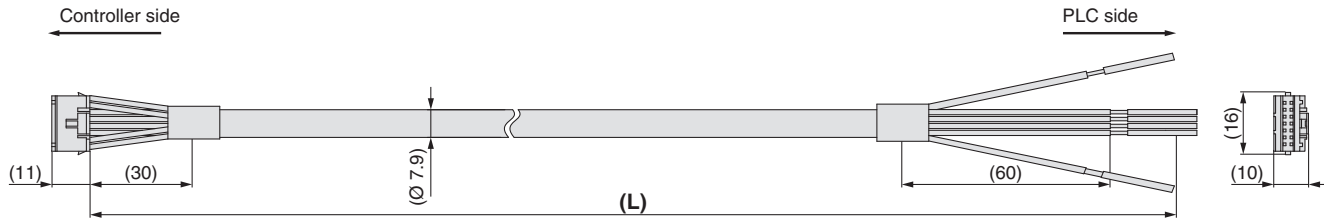

Terminal no.	Insulation colour	Dot mark	Dot colour	Function
1	Light brown	■	Black	COM+
2	Light brown	■	Red	COM-
3	Yellow	■	Black	OUT0
4	Yellow	■	Red	OUT1
5	Light green	■	Black	OUT2
6	Light green	■	Red	OUT3
7	Grey	■	Black	BUSY
8	Grey	■	Red	ALARM
9	White	■	Black	IN0
10	White	■	Red	IN1
11	Light brown	■ ■	Black	IN2
12	Light brown	■ ■	Red	IN3
13	Yellow	■ ■	Black	RESET
14	Yellow	■ ■	Red	STOP

* Conductor size: AWG26

* Parallel I/O signal is valid in auto mode. While the test function operates at manual mode, only the output is valid.

Model Selection

LECP1

LEYG

LECP6

LECP6

LECP1

LECPA

JXC□1

JXC7303/9293

LEYG

LECY

LECS

LECS-T

LECY

LECS-T

LECY

Specific Product Precautions

Pulse Input Type Series **LECPA**



How to Order

⚠ Caution

[CE-compliant products]

- EMC compliance was tested by combining the electric actuator LE series and the LECPA series. The EMC depends on the configuration of the customer's control panel and the relationship with other electrical equipment and wiring. Therefore, conformity to the EMC directive cannot be certified for SMC components incorporated into the customer's equipment under actual operating conditions. As a result, it is necessary for the customer to verify conformity to the EMC directive for the machinery and equipment as a whole.
- For the LECPA series (step motor driver), EMC compliance was tested by installing a noise filter set (LEC-NFA). Refer to page 87 for the noise filter set. Refer to the LECPA Operation Manual for installation.

[UL-compliant products]

When conformity to UL is required, the electric actuator and driver should be used with a UL1310 Class 2 power supply.

LECP AP 1 □ - LEY16B-100

Driver type

AN	Pulse input type (NPN)
AP	Pulse input type (PNP)

I/O cable length [m]

—	None
1	1.5
3	3*
5	5*

* Pulse input usable only with differential. Only 1.5 m cables usable with open collector.

Driver mounting

—	Screw mounting
D (Note)	DIN rail mounting

Note) DIN rail is not included. Order it separately.

Actuator part number

Part number except cable specifications and actuator options
Example: Enter "LEY16B-100"
for the LEY16B-100B-R1AN1D.

BC	Blank controller (Note)
----	-------------------------

Note) The dedicated software (LEC-BCW) is required.

- * When controller equipped type is selected when ordering the LE series, you do not need to order this driver.
- * When pulse signals are open collector, order the current limiting resistor (LEC-PA-R-□) separately.

The driver is sold as single unit after the compatible actuator is set.

Confirm that the combination of the driver and the actuator is correct.

<Check the following before use.>

- Check the actuator label for model number. This matches the driver.
- Check Parallel I/O configuration matches (NPN or PNP).

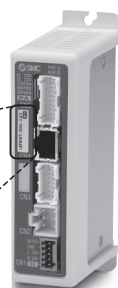
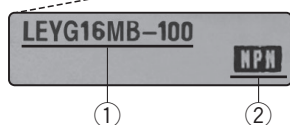

Precautions on blank controller (LECPA□□-BC)

Blank controller is a controller to which the customer can write the data of the actuator to be combined and used. Use the dedicated software (LEC-BCW) for data writing.

- Please download the dedicated software (LEC-BCW) via our website.
- Order the controller setting kit (LEC-W2) separately to use this software.

SMC website
<http://www.smc.eu>

* Refer to the operation manual for using the products. Please download it via our website, <http://www.smc.eu>

Specifications

Item	LECPA
Compatible motor	Step motor (Servo/24 VDC)
Power supply ^{Note 1)}	Power voltage: 24 VDC ±10 % ^{Note 2)} [Including motor drive power, control power, stop, lock release]
Parallel input	5 inputs (Except photo-coupler isolation, pulse input terminal, COM terminal)
Parallel output	9 outputs (Photo-coupler isolation)
Pulse signal input	Maximum frequency: 60 kpps (Open collector), 200 kpps (Differential) Input method: 1 pulse mode (Pulse input in direction), 2 pulse mode (Pulse input in differing directions)
Compatible encoder	Incremental A/B phase (Encoder resolution: 800 pulse/rotation)
Serial communication	RS485 (Modbus protocol compliant)
Memory	EEPROM
LED indicator	LED (Green/Red) one of each
Lock control	Forced-lock release terminal ^{Note 3)}
Cable length [m]	I/O cable: 1.5 or less (Open collector), 5 or less (Differential), Actuator cable: 20 or less
Cooling system	Natural air cooling
Operating temperature range [°C]	0 to 40 (No freezing)
Operating humidity range [%RH]	90 or less (No condensation)
Storage temperature range [°C]	-10 to 60 (No freezing)
Storage humidity range [%RH]	90 or less (No condensation)
Insulation resistance [MΩ]	Between the housing and SG terminal: 50 (500 VDC)
Weight [g]	120 (Screw mounting), 140 (DIN rail mounting)

Note 1) Do not use the power supply of "inrush current prevention type" for the driver power supply. When conformity to UL is required, the electric actuator and driver should be used with a UL1310 Class 2 power supply.

Note 2) The power consumption changes depending on the actuator model. Refer to the specifications of actuator for more details.

Note 3) Applicable to non-magnetizing lock.

How to Mount

a) Screw mounting (LECPA□□-□) (Installation with two M4 screws)

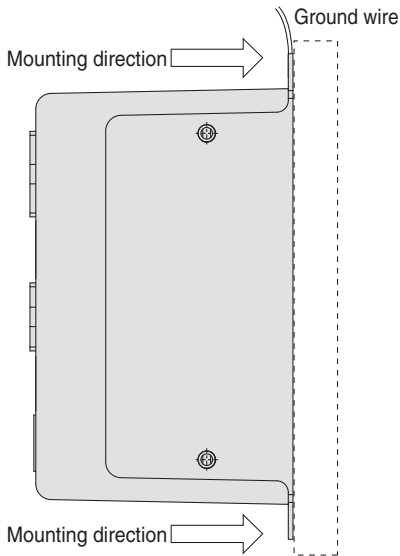

b) DIN rail mounting (LECPA□□D-□) (Installation with the DIN rail)

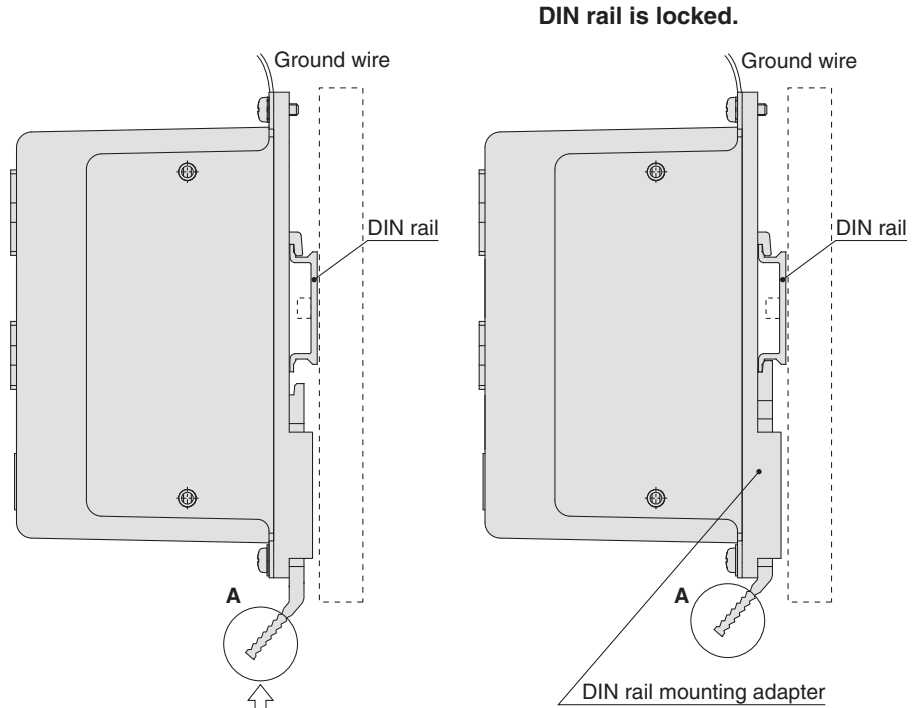

Hook the driver on the DIN rail and press the lever of section A in the arrow direction to lock it.

Note) The space between the drivers should be 10 mm or more.

DIN rail AXT100-DR-□

* For □, enter a number from the "No." line in the table below.
Refer to the dimensions on page 89 for the mounting dimensions.

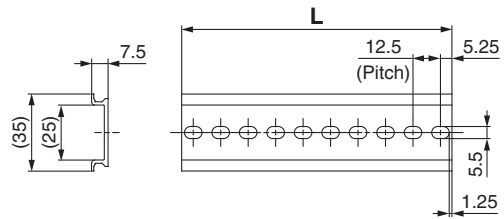

L Dimension [mm]

No.	1	2	3	4	5	6	7	8	9	10	11	12	13	14	15	16	17	18	19	20
L	23	35.5	48	60.5	73	85.5	98	110.5	123	135.5	148	160.5	173	185.5	198	210.5	223	235.5	248	260.5
No.	21	22	23	24	25	26	27	28	29	30	31	32	33	34	35	36	37	38	39	40
L	273	285.5	298	310.5	323	335.5	348	360.5	373	385.5	398	410.5	423	435.5	448	460.5	473	485.5	498	510.5

DIN rail mounting adapter LEC-2-D0 (with 2 mounting screws)

This should be used when the DIN rail mounting adapter is mounted onto the screw mounting type driver afterward.

Series LECPA

Dimensions

a) Screw mounting (LECPA□□-□)

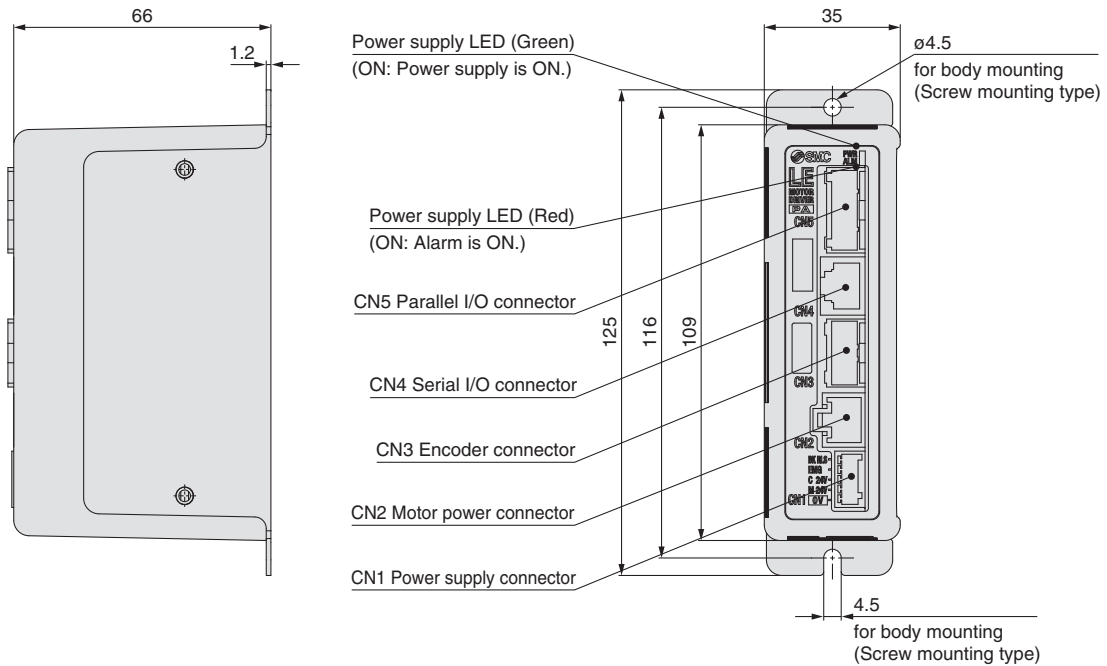

b) DIN rail mounting (LECPA□□D-□)

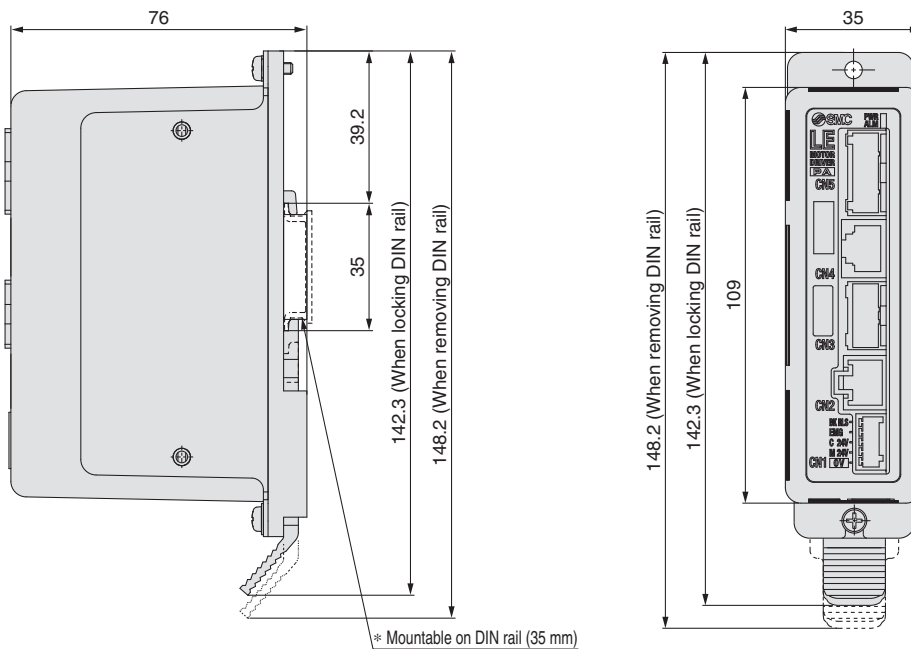

Wiring Example 1

Power Supply Connector: CN1 * Power supply plug is an accessory.

CN1 Power Supply Connector Terminal for LECPA (PHOENIX CONTACT FK-MC0.5/5-ST-2.5)

Terminal name	Function	Details
0V	Common supply (-)	M 24V terminal/C 24V terminal/EMG terminal/BK RLS terminal are common (-).
M 24V	Motor power supply (+)	Motor power supply (+) supplied to the driver
C 24V	Control power supply (+)	Control power supply (+) supplied to the driver
EMG	Stop (+)	Input (+) for releasing the stop
BK RLS	Lock release (+)	Input (+) for releasing the lock

Power supply plug for LECPA

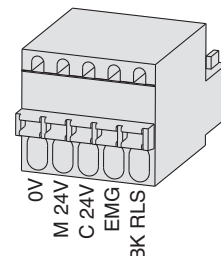

Wiring Example 2

Parallel I/O Connector: CN5 * When you connect a PLC etc., to the CN5 parallel I/O connector, use the I/O cable (LEC-CL5-□).
 * The wiring should be changed depending on the type of the parallel I/O (NPN or PNP).

LECPAN□□-□ (NPN)

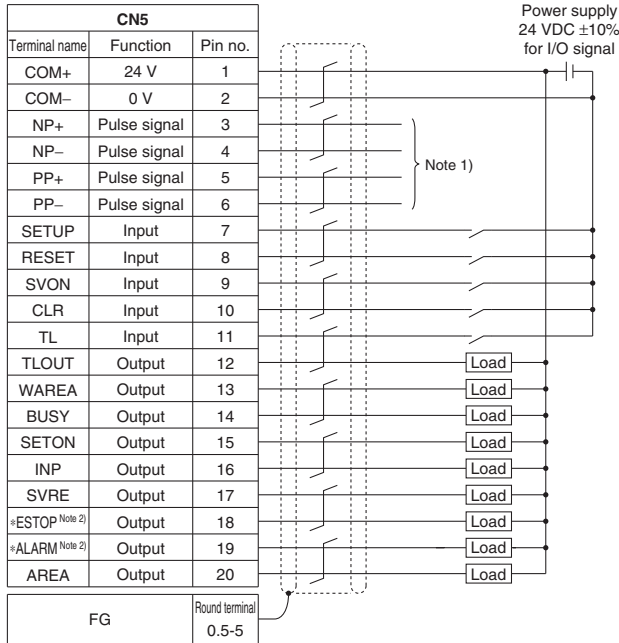

Note 1) For pulse signal wiring method, refer to "Pulse Signal Wiring Details".
 Note 2) Output when the power supply of the driver is ON. (N.C.)

Input Signal

Name	Details
COM+	Connects the power supply 24 V for input/output signal
COM-	Connects the power supply 0 V for input/output signal
SETUP	Instruction to return to origin
RESET	Alarm reset
SVON	Servo ON instruction
CLR	Deviation reset
TL	Instruction to pushing operation

LECPAP□□-□ (PNP)

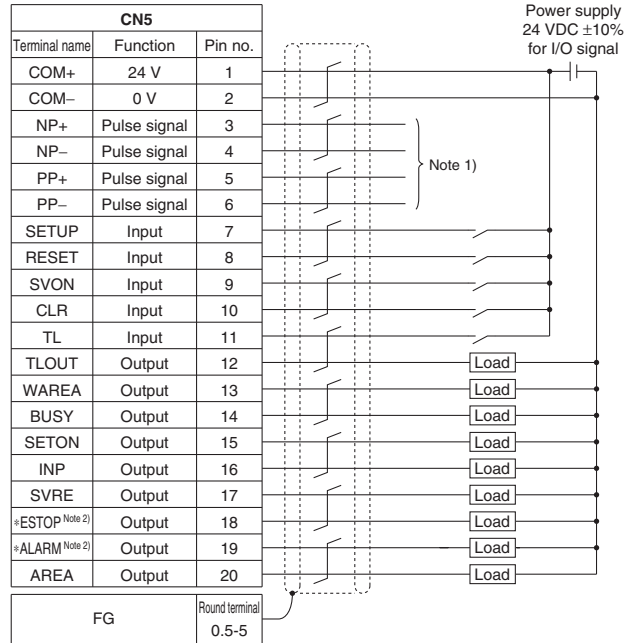

Output Signal

Name	Details
BUSY	Outputs when the actuator is operating
SETON	Outputs when returning to origin
INP	Outputs when target position is reached
SVRE	Outputs when servo is on
*ESTOP ^{Note 3)}	Not output when EMG stop is instructed
*ALARM ^{Note 3)}	Not output when alarm is generated
AREA	Outputs within the area output setting range
WAREA	Outputs within W-AREA output setting range
TLOUT	Outputs during pushing operation

Note 3) Signal of negative-logic circuit ON (N.C.)

Pulse Signal Wiring Details

• Pulse signal output of positioning unit is differential output

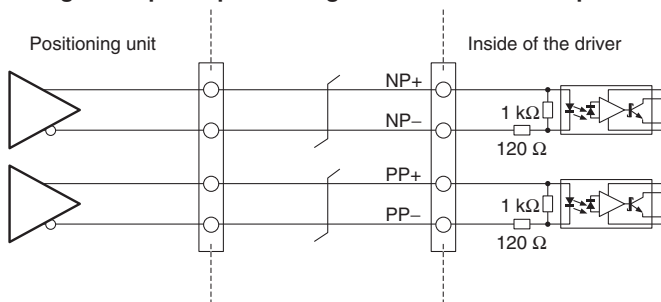

• Pulse signal output of positioning unit is open collector output

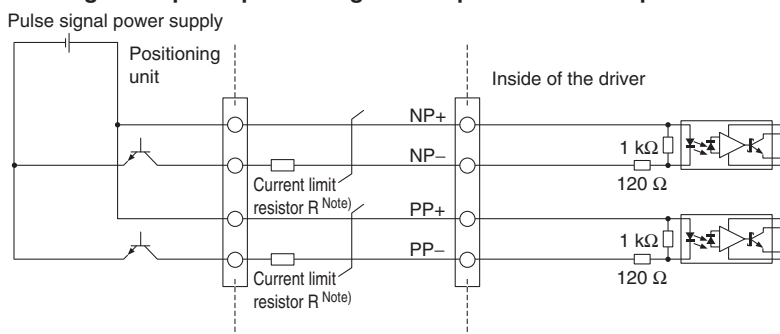

Note) Connect the current limit resistor R in series to correspond to the pulse signal voltage.

Pulse signal power supply voltage	Current limit resistor R specifications	Current limit resistor part no.
24 VDC ±10 %	3.3 kΩ ±5 % (0.5 W or more)	LEC-PA-R-332
5 VDC ±5 %	390 Ω ±5 % (0.1 W or more)	LEC-PA-R-391

Model Selection
 LEY
 LEYG
 LECA6
 LECP6
 LEC-G
 LEC-P1
 LEC-PA
 JXC□1
 JXC7303/02/03
 AC Servo Motor
 LEY
 LEYG
 LEC-S□
 LEC-S-T
 LEC-Y□
 Specific Product Precautions

Series LECPA

Signal Timing

Return to Origin

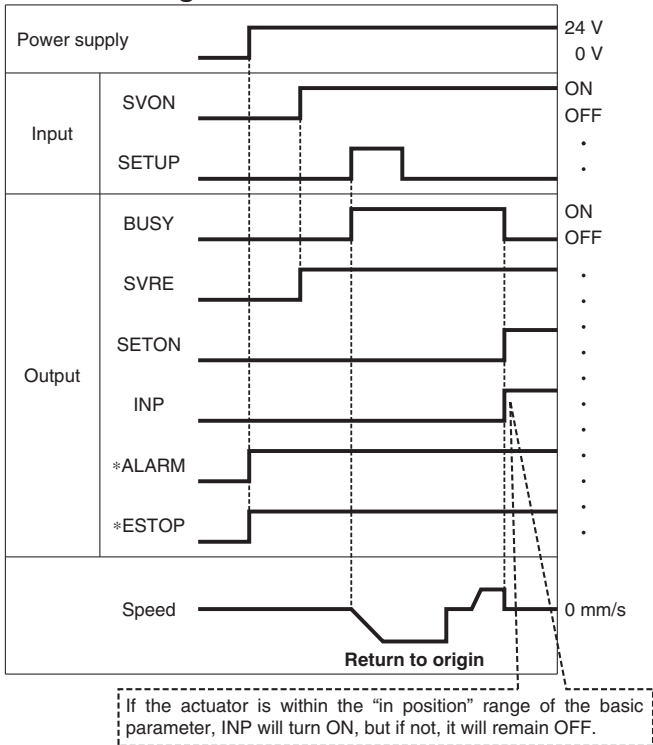

* *ALARM" and *ESTOP" are expressed as negative-logic circuit.

Positioning Operation

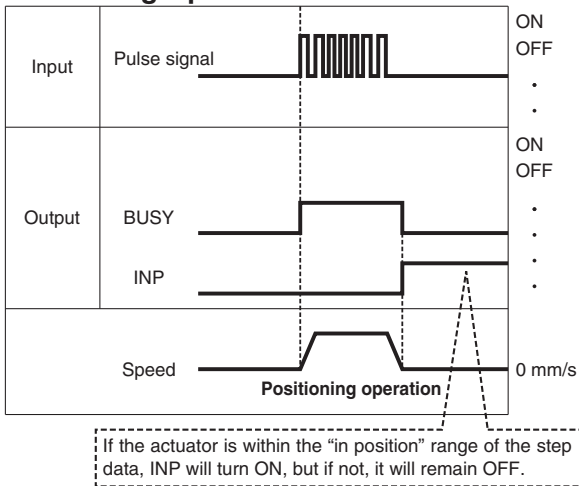

Pushing Operation

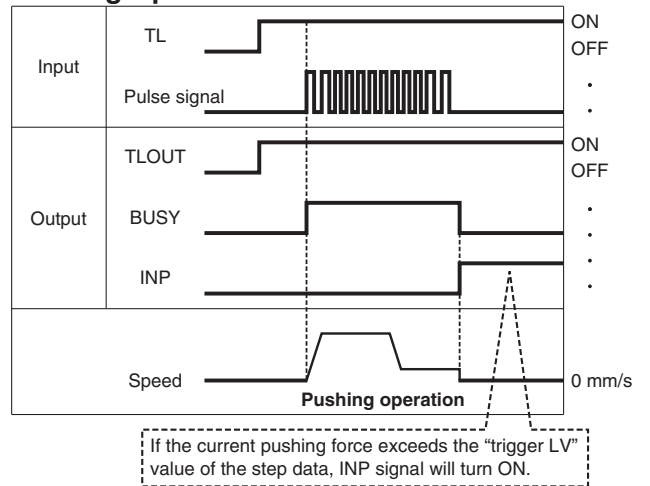

Note) If pushing operation is stopped when there is no pulse deviation, the moving part of the actuator may pulsate.

Alarm Reset

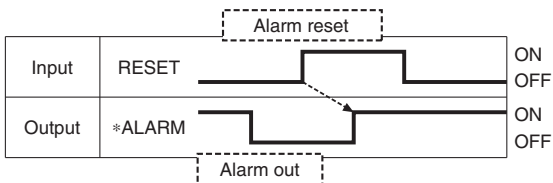

* *ALARM" is expressed as negative-logic circuit.

Options: Actuator Cable

[Robotic cable, standard cable for step motor (Servo/24 VDC)]

LE-CP-1-

Cable length (L) [m]

1	1.5
3	3
5	5
8	8*
A	10*
B	15*
C	20*

* Produced upon receipt of order (Robotic cable only)

Cable type

—	Robotic cable (Flexible cable)
S	Standard cable

LE-CP-¹/₅/Cable length: 1.5 m, 3 m, 5 m

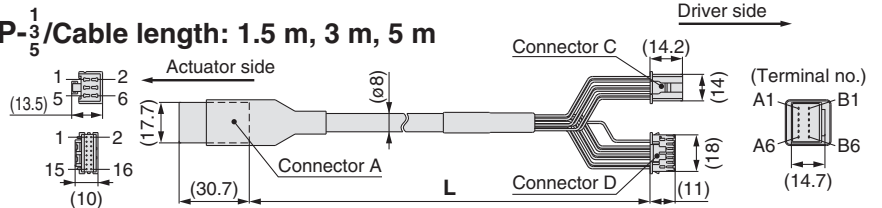

LE-CP-^{8B}/_{AC}/Cable length: 8 m, 10 m, 15 m, 20 m

(* Produced upon receipt of order)

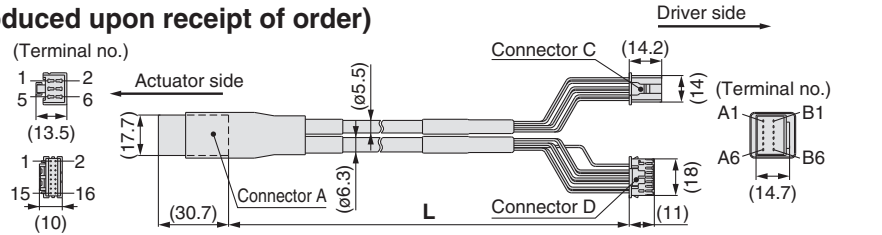

Signal	Connector A terminal no.	Cable colour	Connector C terminal no.
A	B-1	Brown	2
A	A-1	Red	1
B	B-2	Orange	6
B	A-2	Yellow	5
COM-A/COM	B-3	Green	3
COM-B/—	A-3	Blue	4
Shield			
Vcc	B-4	Brown	12
GND	A-4	Black	13
A	B-5	Red	7
A	A-5	Black	6
B	B-6	Orange	9
B	A-6	Black	8
—	—	—	3

[Robotic cable, standard cable with lock and sensor for step motor (Servo/24 VDC)]

LE-CP-1-B-

Cable length (L) [m]

1	1.5
3	3
5	5
8	8*
A	10*
B	15*
C	20*

* Produced upon receipt of order (Robotic cable only)

With lock and sensor

Cable type

—	Robotic cable (Flexible cable)
S	Standard cable

LE-CP-¹/₅/Cable length: 1.5 m, 3 m, 5 m

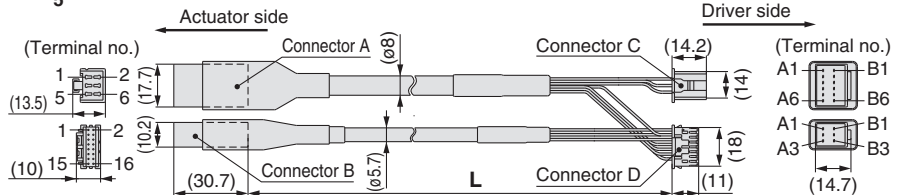

LE-CP-^{8B}/_{AC}/Cable length: 8 m, 10 m, 15 m, 20 m

(* Produced upon receipt of order)

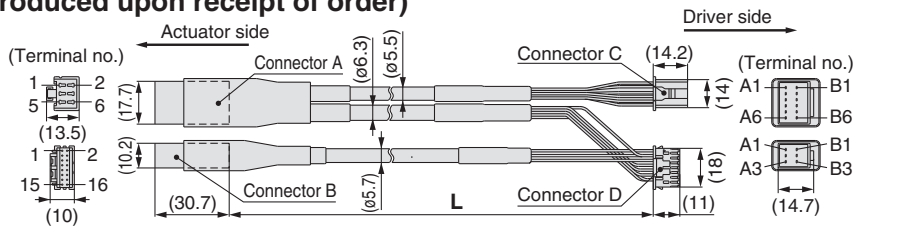

Signal	Connector A terminal no.	Cable colour	Connector C terminal no.
A	B-1	Brown	2
A	A-1	Red	1
B	B-2	Orange	6
B	A-2	Yellow	5
COM-A/COM	B-3	Green	3
COM-B/—	A-3	Blue	4
Shield			
Vcc	B-4	Brown	12
GND	A-4	Black	13
A	B-5	Red	7
A	A-5	Black	6
B	B-6	Orange	9
B	A-6	Black	8
—	—	—	3
Signal	Connector B terminal no.	Cable colour	Connector D terminal no.
Lock (+)	B-1	Red	4
Lock (-)	A-1	Black	5
Sensor (+) (Note)	B-3	Brown	1
Sensor (-) (Note)	A-3	Blue	2

Model Selection
 LEY
 LEYG
 Servo Motor (24 VDC)/Step Motor (Servo/24 VDC)
 LECA6
 LECPC6
 LEC-G
 LECPC1
 LECPA
 JXC□1
 JXC7□/□3/□2/□93
 AC Servo Motor
 LEY
 LEYG
 LECSC
 LECSS-T
 LECY□
 Specific Product Precautions

Series LECPA

Options

[I/O cable]

LEC-C L5 - 1

I/O cable type	
L5	For LECPA

I/O cable length (L)

1	1.5 m
3	3 m*
5	5 m*

* Pulse input usable only with differential. Only 1.5 m cables usable with open collector.

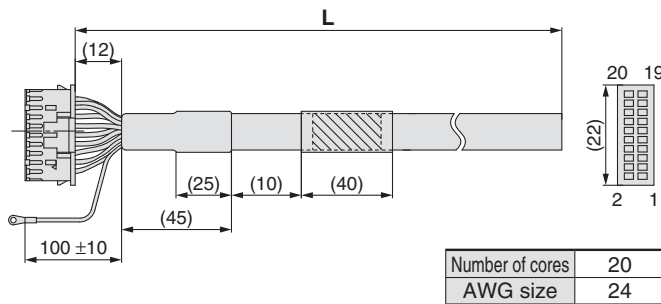

Pin no.	Insulation colour	Dot mark	Dot colour
1	Light brown	■	Black
2	Light brown	■	Red
3	Yellow	■	Black
4	Yellow	■	Red
5	Light green	■	Black
6	Light green	■	Red
7	Grey	■	Black
8	Grey	■	Red
9	White	■	Black
10	White	■	Red
11	Light brown	■ ■	Black

Pin no.	Insulation colour	Dot mark	Dot colour
12	Light brown	■ ■	Red
13	Yellow	■ ■	Black
14	Yellow	■ ■	Red
15	Light green	■ ■	Black
16	Light green	■ ■	Red
17	Grey	■ ■	Black
18	Grey	■ ■	Red
19	White	■ ■	Black
20	White	■ ■	Red
Round terminal 0.5-5	Green		

[Noise filter set]

Step motor driver (Pulse input type)

LEC-NFA

Contents of the set: 2 noise filters
(Manufactured by WURTH ELEKTRONIK: 74271222)

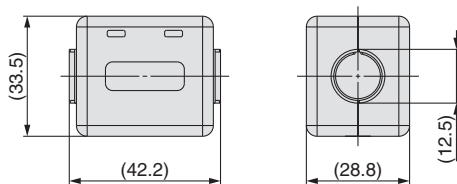

* Refer to the LECPA series Operation Manual for installation.

[Current limit resistor]

This optional resistor (LEC-PA-R-□) is used when the pulse signal output of the positioning unit is open collector output.

LEC-PA-R-□

Current limit resistor

Symbol	Resistance	Pulse signal power supply voltage
332	3.3 kΩ ±5 %	24 VDC ±10 %
391	390 Ω ±5 %	5 VDC ±5 %

* Select a current limit resistor that corresponds to the pulse signal power supply voltage.
* For the LEC-PA-R-□, two pieces are shipped as a set.

Controller Setting Kit/LEC-W2

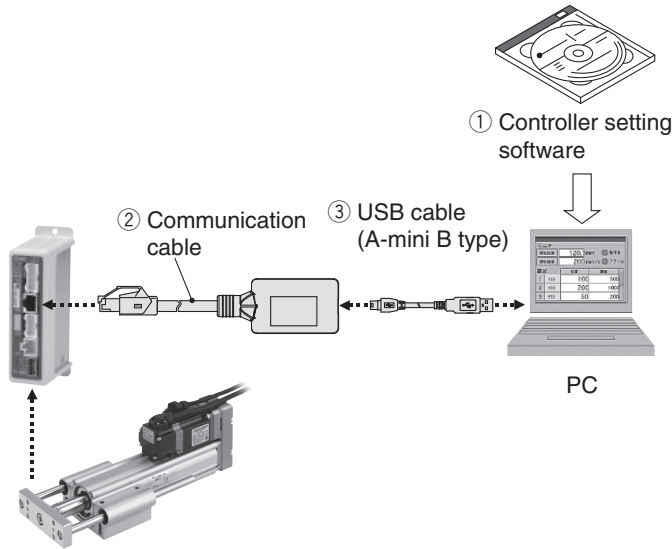

How to Order

LEC-W2

Controller setting kit
 (Japanese and English are available.)

Contents

	Description	Model*
①	Controller setting software (CD-ROM)	LEC-W2-S
②	Communication cable	LEC-W2-C
③	USB cable (between the PC and the communication cable)	LEC-W2-U

* Can be ordered separately.

Compatible Controller/Driver

Step data input type
 Pulse input type

Series **LECP6**/Series **LECA6**
 Series **LECPA**

Hardware Requirements

OS	IBM PC/AT compatible machine running Windows®XP (32-bit), Windows®7 (32-bit and 64-bit), Windows®8.1 (32-bit and 64-bit).
Communication interface	USB 1.1 or USB 2.0 ports
Display	XGA (1024 x 768) or more

* Windows®XP, Windows®7 and Windows®8.1 are registered trademarks of Microsoft Corporation in the United States.
 * Refer to SMC website for version upgrade information, <http://www.smc.eu>

Screen Example

Easy mode screen example

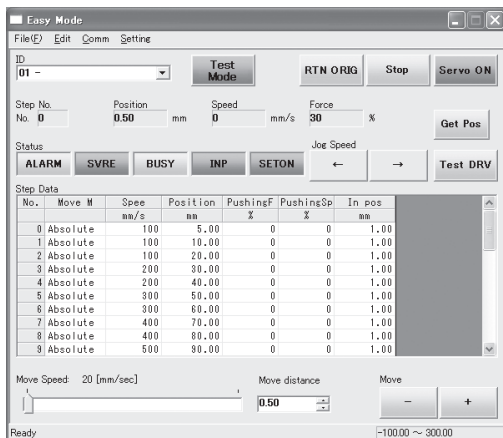

Easy operation and simple setting

- Allowing to set and display actuator step data such as position, speed, force, etc.
- Setting of step data and testing of the drive can be performed on the same page.
- Can be used to jog and move at a constant rate.

Normal mode screen example

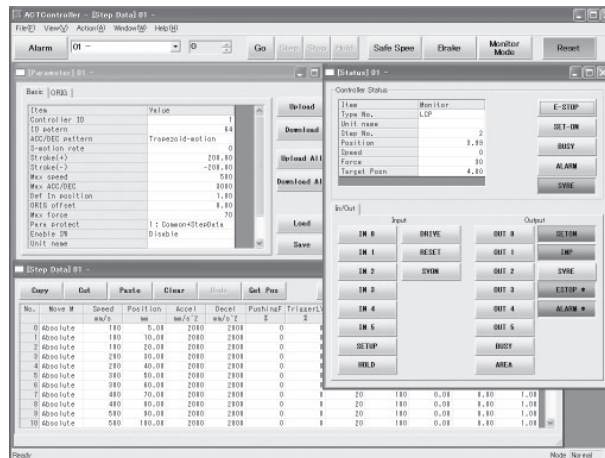

Detailed setting

- Step data can be set in detail.
- Signals and terminal status can be monitored.
- Parameters can be set.
- JOG and constant rate movement, return to origin, test operation and testing of forced output can be performed.

Model Selection

LEY

LEYG

LECA6
LECP6

LECG

LECP1

LECPA

JXC□1

JXC7□0□3□2□9□3

LEY

AC Servo Motor

LEYG

LECS□

LECS-T

LECY□

Specific Product Precautions

Series LEC Teaching Box/LEC-T1



How to Order

LEC-T1-3EG

Teaching box

Cable length [m]
3 3

Initial language
J Japanese
E English

* The displayed language can be changed to English or Japanese.

Enable switch

—	None
S	Equipped with enable switch

* Interlock switch for jog and test function

Stop switch

G	Equipped with stop switch
---	---------------------------

Standard functions

- Chinese character display
- Stop switch is provided.

Option

- Enable switch is provided.

Specifications

Item	Description
Switch	Stop switch, Enable switch (Option)
Cable length [m]	3
Enclosure	IP64 (Except connector)
Operating temperature range [°C]	5 to 50
Operating humidity range [%RH]	90 or less (No condensation)
Weight [g]	350 (Except cable)

[CE-compliant products]

The EMC compliance of the teaching box was tested with the LECPC6 series step motor controller (servo/24 VDC) and an applicable actuator.

[UL-compliant products]

When conformity to UL is required, the electric actuator and driver should be used with a UL1310 Class 2 power supply.

Easy Mode

Function	Details
Step data	• Setting of step data
Jog	• Jog operation • Return to origin
Test	• 1 step operation ^{Note 1)} • Return to origin
Monitor	• Display of axis and step data no. • Display of two items selected from Position, Speed, Force.
ALM	• Active alarm display • Alarm reset
TB setting	• Reconnection of axis (Ver. 1.**) • Displayed language setting (Ver. 2.**) • Setting of easy/normal mode • Setting step data and selection of items from easy mode monitor

Menu Operations Flowchart

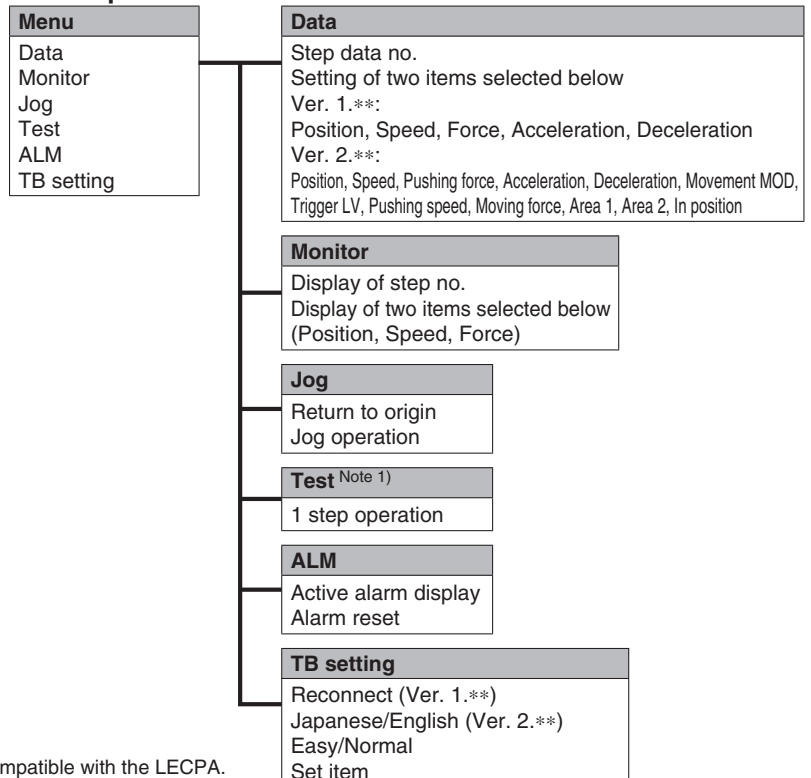

Note 1) Not compatible with the LECPC6.

Normal Mode

Function	Details
Step data	• Step data setting
Parameter	• Parameters setting
Test	<ul style="list-style-type: none"> • Jog operation/Constant rate movement • Return to origin • Test drive ^{Note 1)} (Specify a maximum of 5 step data and operate.) • Forced output (Forced signal output, Forced terminal output) ^{Note 2)}
Monitor	<ul style="list-style-type: none"> • Drive monitor • Output signal monitor ^{Note 2)} • Input signal monitor ^{Note 2)} • Output terminal monitor • Input terminal monitor
ALM	<ul style="list-style-type: none"> • Active alarm display (Alarm reset) • Alarm log record display
File	<ul style="list-style-type: none"> • Data saving Save the step data and parameters of the driver which is being used for communication (it is possible to save four files, with one set of step data and parameters defined as one file). • Load to driver Loads the data which is saved in the teaching box to the driver which is being used for communication. • Delete the saved data. • File protection (Ver. 2.**)
TB setting	<ul style="list-style-type: none"> • Display setting (Easy/Normal mode) • Language setting (Japanese/English) • Backlight setting • LCD contrast setting • Beep sound setting • Max. connection axis • Distance unit (mm/inch)
Reconnect	• Reconnection of axis

Menu Operations Flowchart

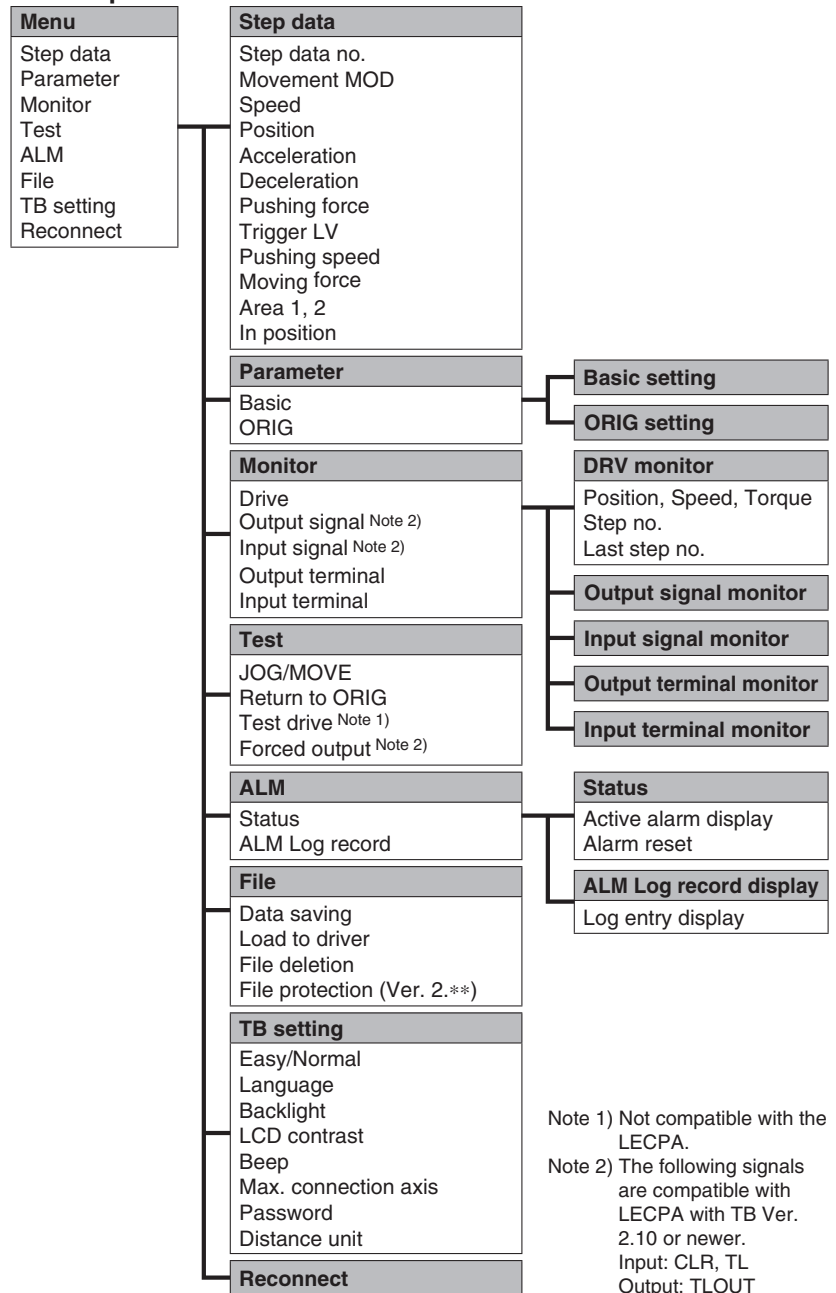

Dimensions

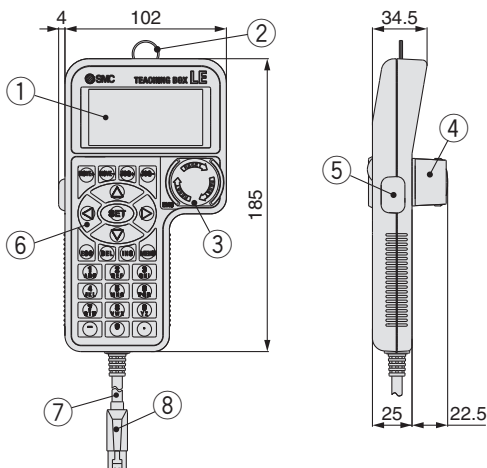

No.	Description	Function
1	LCD	A screen of liquid crystal display (with backlight)
2	Ring	A ring for hanging the teaching box
3	Stop switch	When switch is pushed in, the switch locks and stops. The lock is released when it is turned to the right.
4	Stop switch guard	A guard for the stop switch
5	Enable switch (Option)	Prevents unintentional operation (unexpected operation) of the jog test function. Other functions such as data change are not covered.
6	Key switch	Switch for each input
7	Cable	Length: 3 meters
8	Connector	A connector connected to CN4 of the driver

Model Selection

Servo Motor (24 VDC) (Step Motor (Servo/24 VDC))
LEY
LEYG

LECA6
LECP6

LEC-G
LECP1

LECPA

JXC□1

JXC7□/□3/□2/□93

LEY

LEYG

AC Servo Motor
LEY
LEYG

LECS□

LECS-T

LECY□

Specific Product
Precautions

Step Motor Controller



5 types of communication protocols

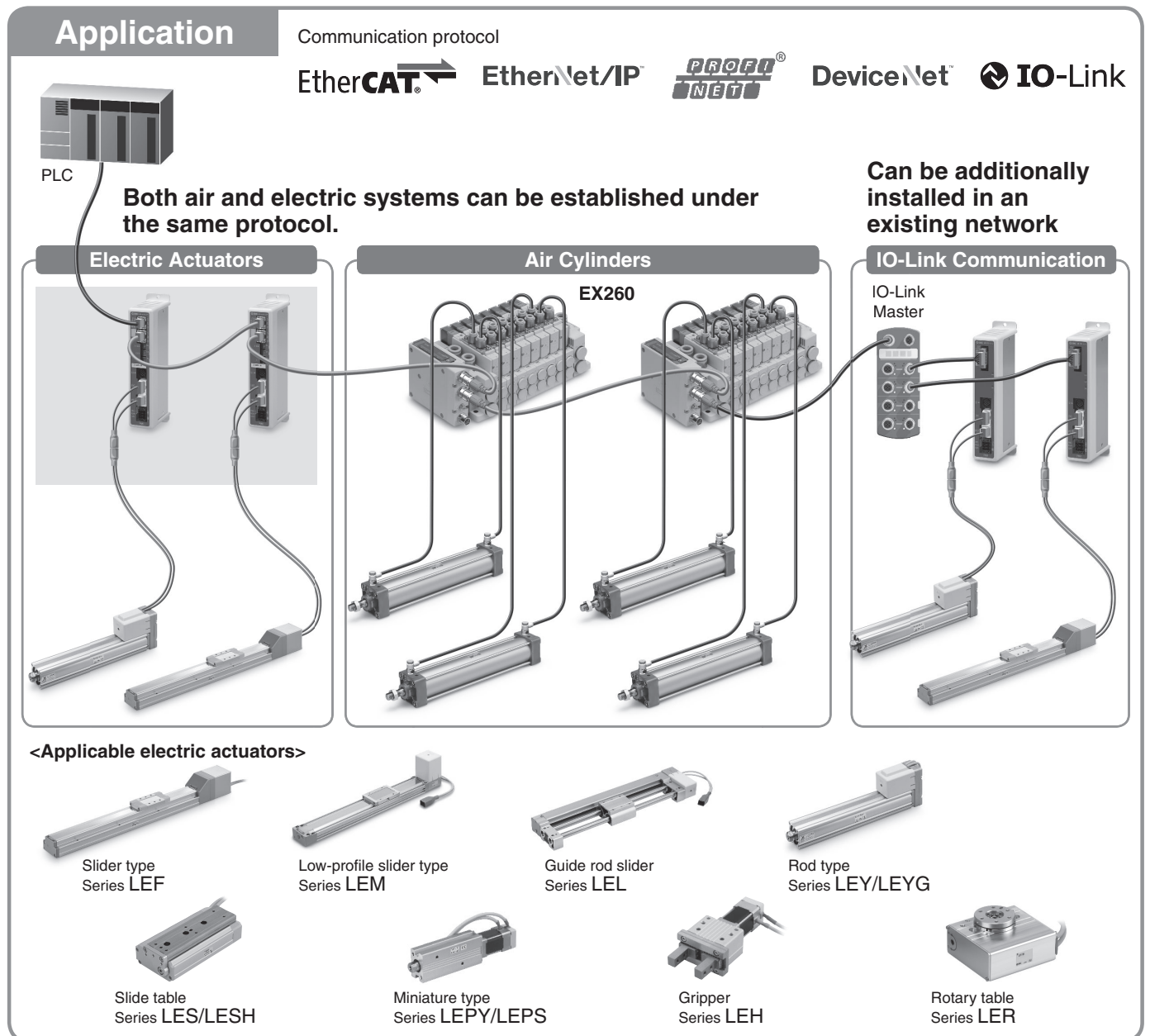

Series JXCE1/91/P1/D1/L1



Model Selection

LEY

LEYG

LECA6
LECP6

LEC-G

LECP1

LECPA

JXC□1

JXC73/63/52/33

LEY

AC Servo Motor

LEYG

LECS□

LECS-T

LECY□

Specific Product Precautions

Two types of operation command

Step no. defined operation: Operate using the preset step data in the controller.

Numerical data defined operation: The actuator operates using values such as position and speed from the PLC.

Numerical monitoring available

Numerical information, such as the current speed, current position, and alarm codes, can be monitored on the PLC.

Transition wiring of communication cables

Two communication ports are provided.

* For the DeviceNet™ type, transition wiring is possible using a branch connector.

* 1 to 1 in the case of IO-Link

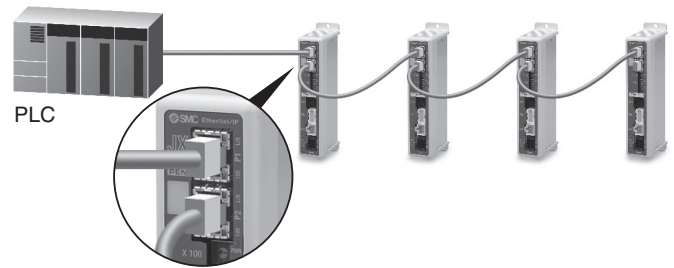

IO-Link communication can be performed.

The data storage function eliminates the need for troublesome resetting of step data and parameters when changing over the controller.

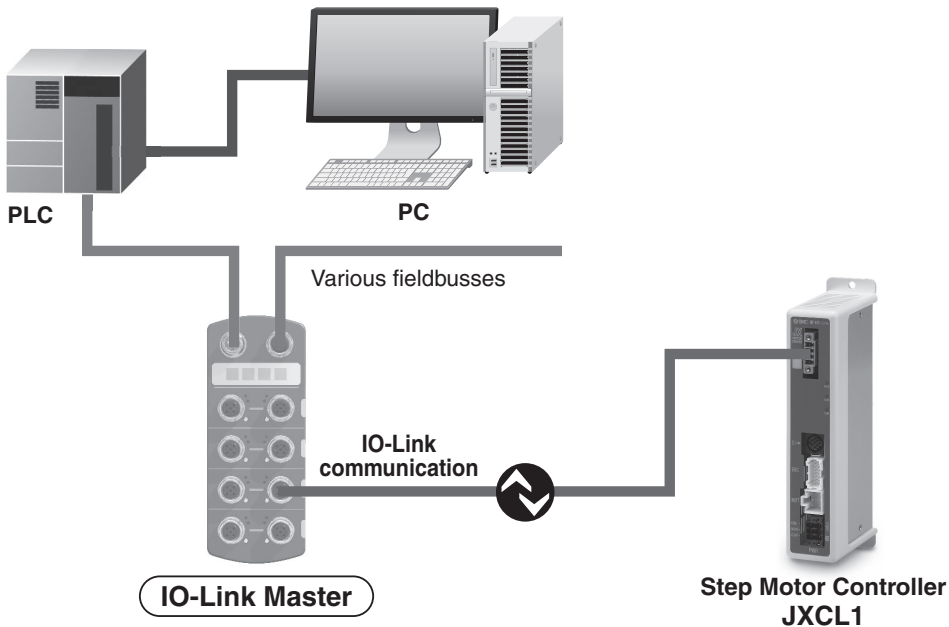

IO-Link is an open communication interface technology between the sensor/actuator and the I/O terminal that is an international standard, IEC61131-9.

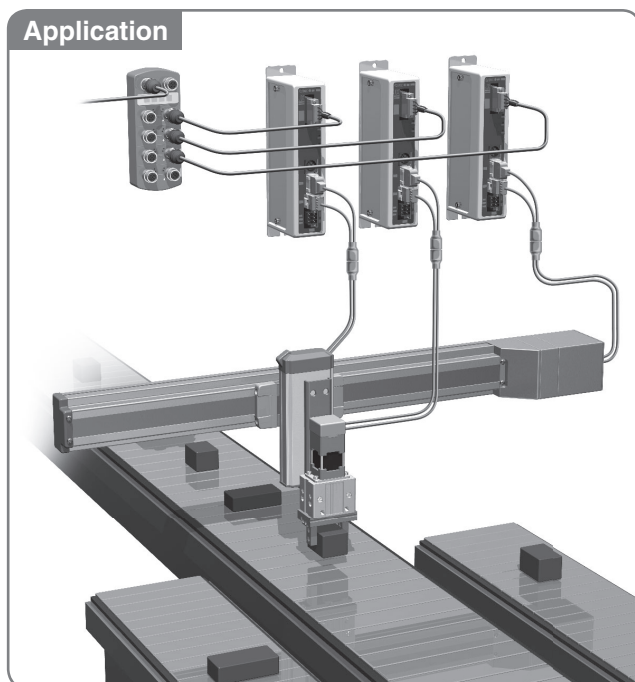

● Step data and parameters can be set from the master side.

Step data and parameters can be set or changed by means of IO-Link communication.

● Data storage function

When the controller is changed, the parameters and step data for the actuator are automatically set.*¹

● 4-wire unshielded cables can be used.

*¹ The “basic parameter” and the “return to origin parameter” are automatically set as the actuator parameters, and the 3 items of data consisting of No. 0 to 2 are automatically set as the step data.

System Construction

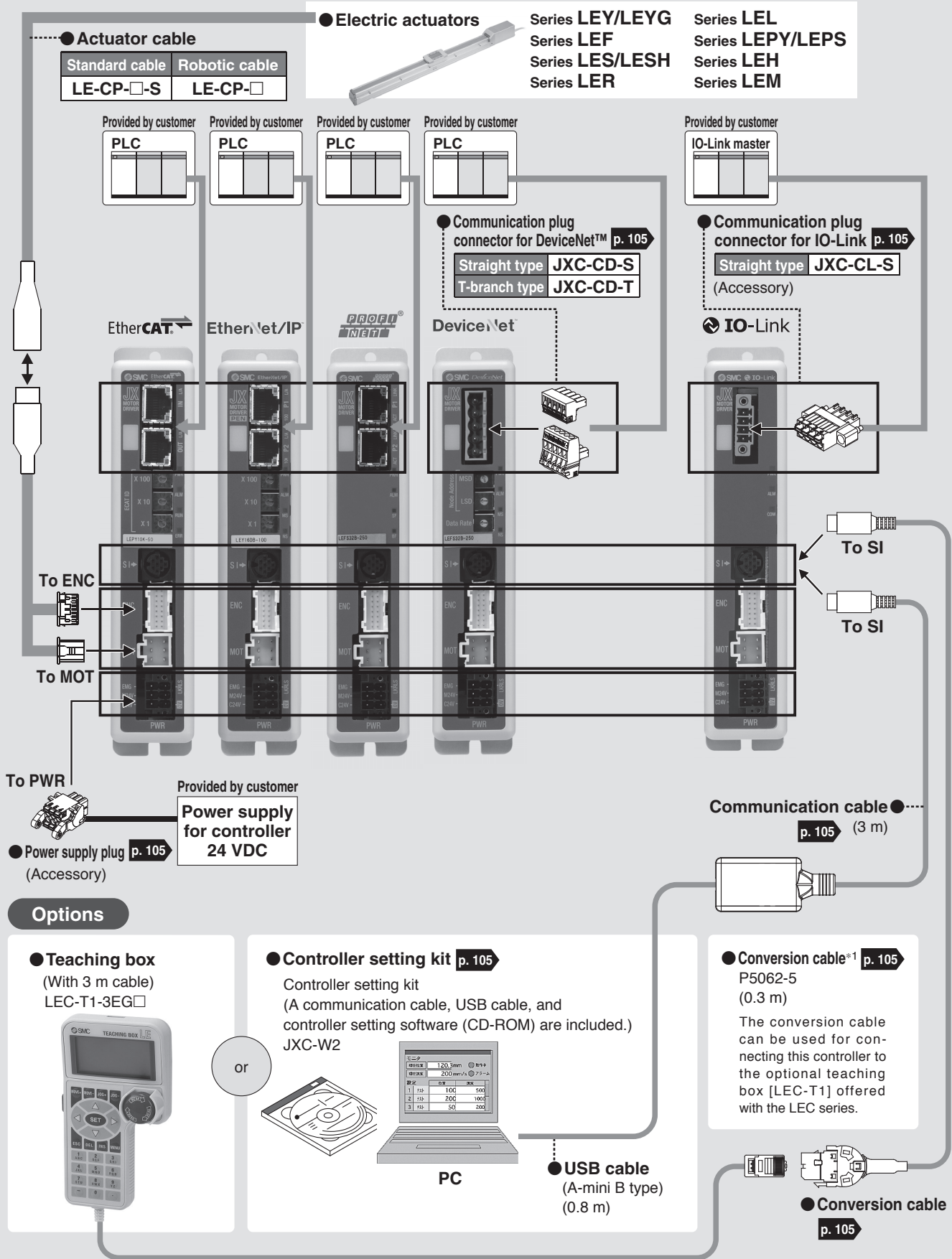

*1 A conversion cable is also required for connecting the controller to the LEC-W2. (A conversion cable is not required for the JXC-W2.)

Model Selection	LEY
Servo Motor (24 VDC)/Step Motor (Servo/24 VDC)	LEYG
LECA6	LECP6
LEC-G	LEC-P1
LEC-PA	LEC-P1
JXC-□1	JXC-□1
JXC730/83/92/93	JXC730/83/92/93
AC Servo Motor	LEY
LEYG	LEYG
LECS□	LECS□
LECS-T	LECS-T
LECY□	LECY□
Specific Product Precautions	Specific Product Precautions

Step Motor Controller

Series **JXCE1/91/P1/D1/L1**



How to Order



Actuator + Controller

LEY16B-100 - R1 CD17T

Actuator type

Refer to "How to Order" in the actuator catalogue available at www.smc.eu.
For compatible actuators, refer to the table below. Example: LEY16B-100B-R1C917

Compatible actuators		Refer to the Web Catalogue.
Electric Actuator/Rod	Series LEY	
Electric Actuator/Guide Rod	Series LEYG	
Electric Actuator/Slider	Series LEF	
Electric Slide Table	Series LES/LESH	
Electric Rotary Table	Series LER	
Electric Actuator/Guide Rod Slider	Series LEL	
Electric Actuator/Miniature	Series LEPY/LEPS	
Electric Gripper	Series LEH	
Electric Actuator/Low-Profile Slider	Series LEM	

* Only the step motor type is applicable.

Controller

—	Without controller
C□1□□	With controller

CD17T

Communication protocol

E	EtherCAT®
9	EtherNet/IP™
P	PROFINET
D	DeviceNet™
L	IO-Link

Mounting

7	Screw mounting
8*1	DIN rail

*1 The DIN rail is not included. It must be ordered separately. (Refer to page 105.)

For single axis

Actuator cable type/length

—	Without cable
S1	Standard cable 1.5 m
S3	Standard cable 3 m
S5	Standard cable 5 m
R1	Robotic cable 1.5 m
R3	Robotic cable 3 m
R5	Robotic cable 5 m
R8	Robotic cable 8 m*1
RA	Robotic cable 10 m*1
RB	Robotic cable 15 m*1
RC	Robotic cable 20 m*1

*1 Produced upon receipt of order (Robotic cable only)
* The standard cable should only be used on fixed parts. For use on moving parts, select the robotic cable.

Caution

[CE-compliant products]

EMC compliance was tested by combining the electric actuator LE series and the JXCE1/91/P1/D1/L1 series.

The EMC depends on the configuration of the customer's control panel and the relationship with other electrical equipment and wiring. Therefore, compliance with the EMC directive cannot be certified for SMC components incorporated into the customer's equipment under actual operating conditions. As a result, it is necessary for the customer to verify compliance with the EMC directive for the machinery and equipment as a whole.

Option

—	Without option
S	With straight type DeviceNet™ communication plug for JXCD1
T	With T-branch type DeviceNet™ communication plug for JXCD1

* Select "Nil" for anything other than JXCD1.

When selecting an electric actuator, refer to the model selection chart of each actuator. Also, for the "Speed-Work Load" graph of the actuator, refer to the LCEP6 section on the model selection page of the electric actuators **Web Catalogue**.

Controller

JXC D 1 7 T - LEY16B-100

Precautions for blank controllers (JXC□1□□-BC)

A blank controller is a controller to which the customer can write the data of the actuator it is to be combined and used with. Use the dedicated software (JXC-BCW) for data writing.

- Please download the dedicated software (JXC-BCW) via our website.
- Order the controller setting kit (LEC-W2) separately to use this software.

SMC website
<http://www.smc.eu>

Communication protocol

E	EtherCAT®
9	EtherNet/IP™
P	PROFINET
D	DeviceNet™
L	IO-Link

For single axis

Mounting

7	Screw mounting
8*1	DIN rail

*1 The DIN rail is not included. It must be ordered separately. (Refer to page 105.)

Actuator part number

Without cable specifications and actuator options
Example: Enter "**LEY16B-100**" for the LEY16B-100B-S1□□.

BC Blank controller*1

*1 Requires dedicated software (JXC-BCW)

Option

—	Without option
S	With straight type DeviceNet™ communication plug for JXCD1
T	With T-branch type DeviceNet™ communication plug for JXCD1

* Select "Nil" for anything other than JXCD1.

When selecting an electric actuator, refer to the model selection chart of each actuator. Also, for the "Speed-Work Load" graph of the actuator, refer to the LCEP6 section on the model selection page of the electric actuators **Web Catalogue**.

Specifications

Model		JXCE1	JXC91	JXCP1	JXCD1	JXCL1
Network		EtherCAT®	EtherNet/IP™	PROFINET	DeviceNet™	IO-Link
Compatible motor		Step motor (Servo/24 VDC)				
Power supply		Power voltage: 24 VDC ±10 %				
Current consumption (Controller)		200 mA or less	130 mA or less	200 mA or less	100 mA or less	100 mA or less
Compatible encoder		Incremental A/B phase (800 pulse/rotation)				
Communication specifications	Applicable system	EtherCAT®*2	EtherNet/IP™*2	PROFINET*2	DeviceNet™	IO-Link
	Protocol	EtherCAT®*2	EtherNet/IP™*2	PROFINET*2	DeviceNet™	IO-Link
	Version*1	Conformance Test Record V.1.2.6	Volume 1 (Edition 3.14) Volume 2 (Edition 1.15)	Specification Version 2.32	Volume 1 (Edition 3.14) Volume 3 (Edition 1.13)	Version 1.1 Port Class A
	Communication speed	100 Mbps*2	10/100 Mbps*2 (Automatic negotiation)	100 Mbps*2	125/250/500 kbps	230.4 kbps (COM3)
	Configuration file*3	ESI file	EDS file	GSDML file	EDS file	IODD file
	I/O occupation area	Input 20 bytes Output 36 bytes	Input 36 bytes Output 36 bytes	Input 36 bytes Output 36 bytes	Input 4, 10, 20 bytes Output 4, 12, 20, 36 bytes	Input 14 bytes Output 22 bytes
Terminating resistor		Not included				
Memory		EEPROM				
LED indicator		PWR, RUN, ALM, ERR	PWR, ALM, MS, NS	PWR, ALM, SF, BF	PWR, ALM, MS, NS	PWR, ALM, COM
Cable length [m]		Actuator cable: 20 or less				
Cooling system		Natural air cooling				
Operating temperature range [°C]		0 to 40 (No freezing)				
Operating humidity range [%RH]		90 or less (No condensation)				
Insulation resistance [MΩ]		Between all external terminals and the case 50 (500 VDC)				
Weight [g]		220 (Screw mounting) 240 (DIN rail mounting)	210 (Screw mounting) 230 (DIN rail mounting)	220 (Screw mounting) 240 (DIN rail mounting)	210 (Screw mounting) 230 (DIN rail mounting)	190 (Screw mounting) 210 (DIN rail mounting)

*1 Please note that versions are subject to change.

*2 Use a shielded communication cable with CAT5 or higher for the PROFINET, EtherNet/IP™, and EtherCAT®.

*3 The files can be downloaded from the SMC website: <http://www.smc.eu>

■Trademark

EtherNet/IP™ is a trademark of ODVA.

DeviceNet™ is a trademark of ODVA.

EtherCAT® is registered trademark and patented technology, licensed by Beckhoff Automation GmbH, Germany.

Example of Operation Command

In addition to the step data input of 64 points maximum in each communication protocol, the changing of each parameter can be performed in real time via numerical data defined operation.

* Numerical values other than "Moving force," "Area 1," and "Area 2" can be used to perform operation under numerical instructions from JXCL1.

<Application example> Movement between 2 points

No.	Movement mode	Speed	Position	Acceleration	Deceleration	Pushing force	Trigger LV	Pushing speed	Moving force	Area 1	Area 2	In position
0	1: Absolute	100	10	3000	3000	0	0	0	100	0	0	0.50
1	1: Absolute	100	100	3000	3000	0	0	0	100	0	0	0.50

<Step no. defined operation>

Sequence 1: Servo ON instruction

Sequence 2: Instruction to return to origin

Sequence 3: Specify step data No. 0 to input the DRIVE signal.

Sequence 4: Specify step data No. 1 after the DRIVE signal has been temporarily turned OFF to input the DRIVE signal.

<Numerical data defined operation>

Sequence 1: Servo ON instruction

Sequence 2: Instruction to return to origin

Sequence 3: Specify step data No. 0 and turn ON the input instruction flag (position). Input 10 in the target position. Subsequently the start flag turns ON.

Sequence 4: Turn ON step data No. 0 and the input instruction flag (position) to change the target position to 100 while the start flag is ON.

The same operation can be performed with any operation command.

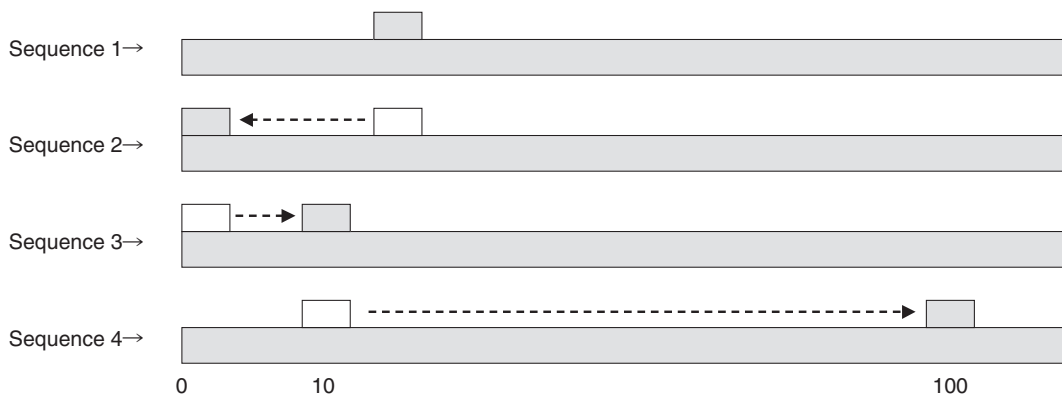

Series JXCE1/91/P1/D1/L1

Dimensions



JXCE1/JXC91

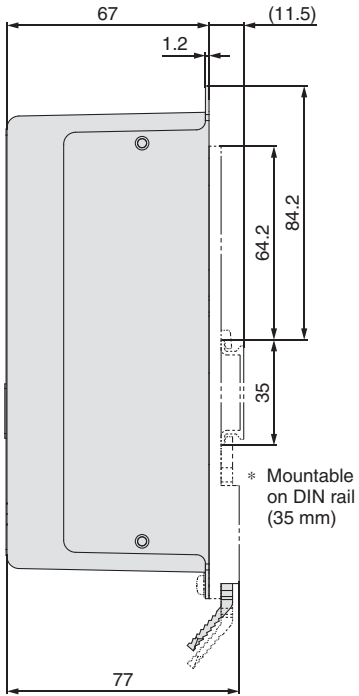

JXCE1

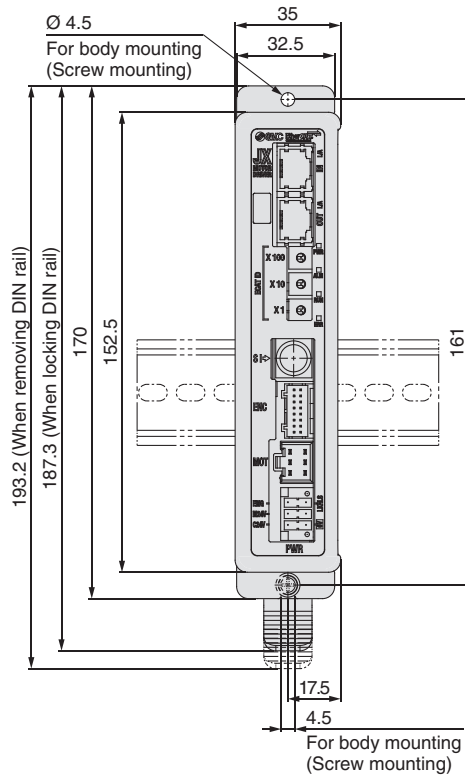

JXC91

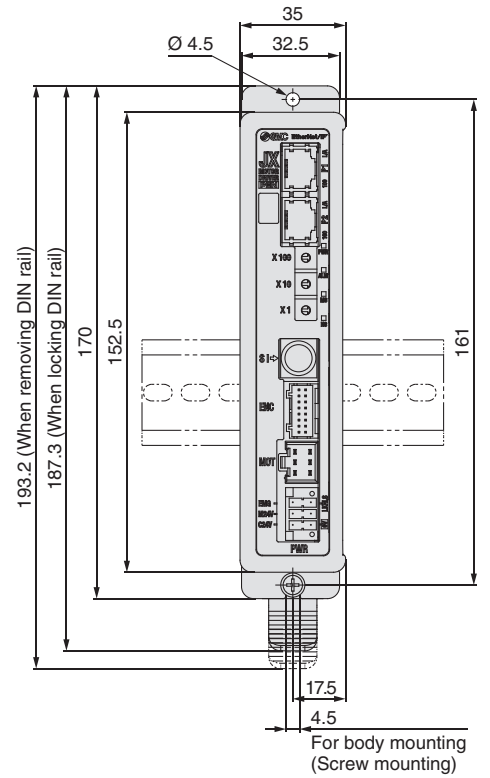

JXCP1/JXCD1

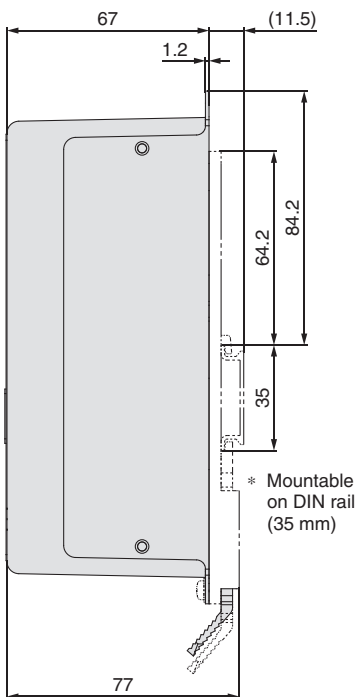

JXCP1

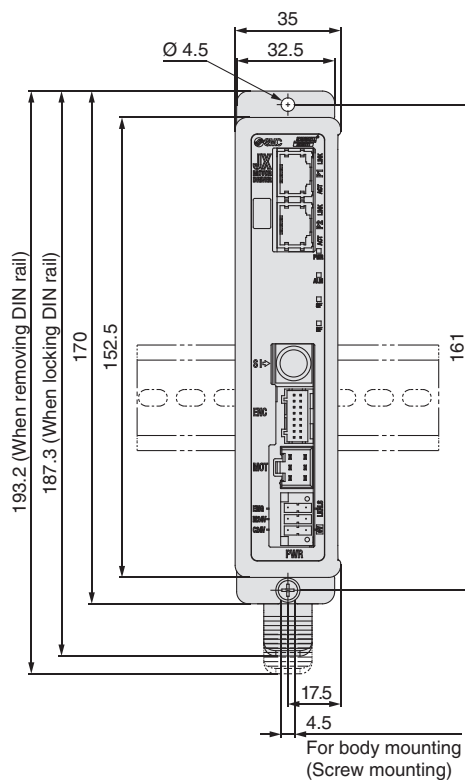

JXCD1

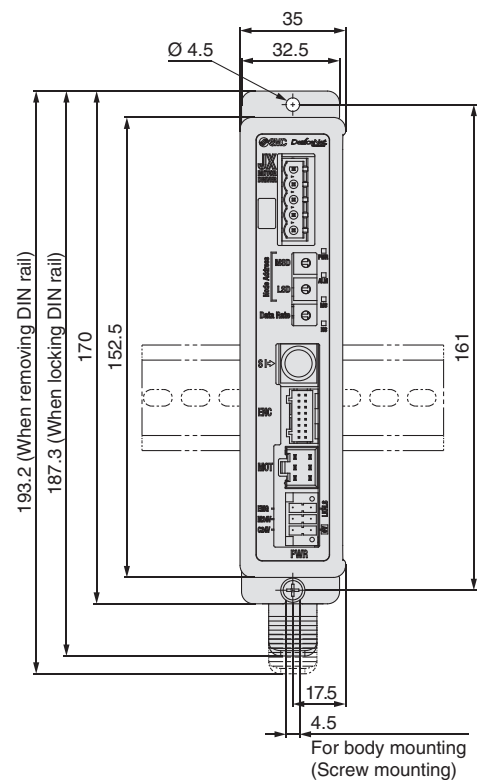

Dimensions

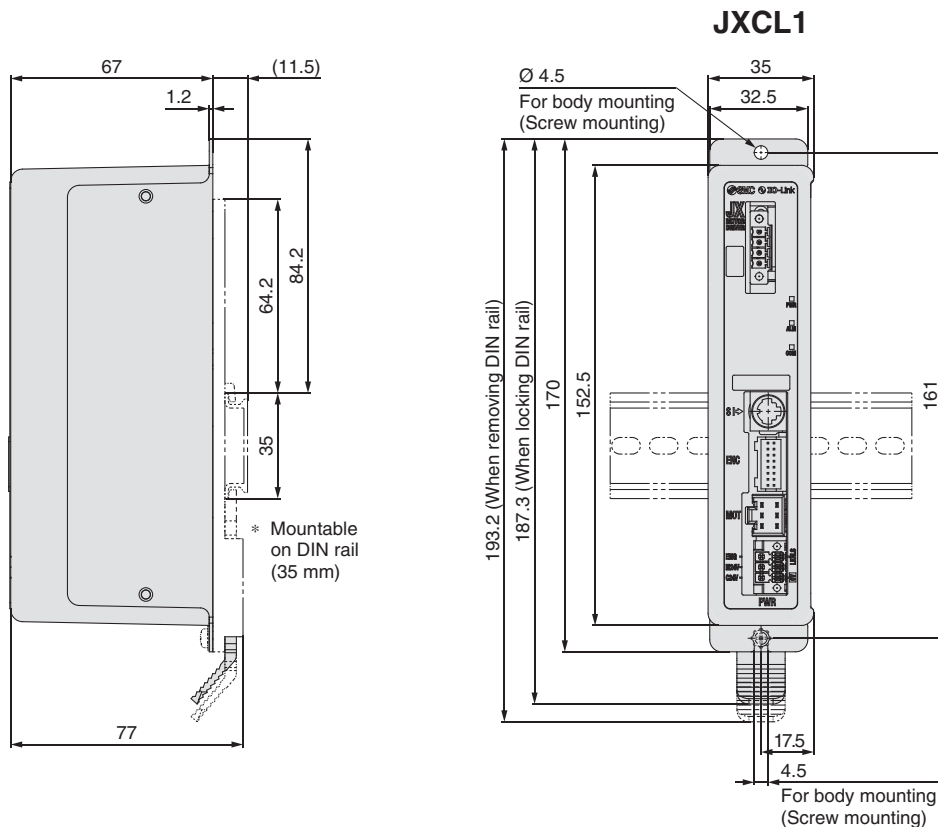

DIN rail AXT100-DR-□

* For □, enter a number from the "No." line in the table below.

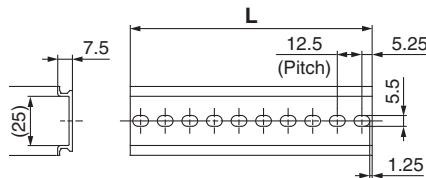

L Dimensions [mm]

No.	1	2	3	4	5	6	7	8	9	10	11	12	13	14	15	16	17	18	19	20
L	23	35.5	48	60.5	73	85.5	98	110.5	123	135.5	148	160.5	173	185.5	198	210.5	223	235.5	248	260.5
No.	21	22	23	24	25	26	27	28	29	30	31	32	33	34	35	36	37	38	39	40
L	273	285.5	298	310.5	323	335.5	348	360.5	373	385.5	398	410.5	423	435.5	448	460.5	473	485.5	498	510.5

Model Selection

Servo Motor (24 VDC)/Step Motor (Servo/24 VDC)

LEYG

LEY

LECA6
LECP6

LEC-G

LECP1

LECPA

JXC□1

JXC7303/92/93

AC Servo Motor

LEYG

LEY

LECS□

LECS-T

LECY□

Specific Product Precautions

Series JXCE1/91/P1/D1/L1

Options

■ Controller setting kit JXC-W2

[Contents]

- ① Communication cable
- ② USB cable
- ③ Controller setting software
- * A conversion cable (P5062-5) is not required.

JXC-W2-□

● Contents

—	A kit includes: Communication cable, USB cable, Controller setting software
C	Communication cable
U	USB cable
S	Controller setting software (CD-ROM)

① Communication cable JXC-W2-C

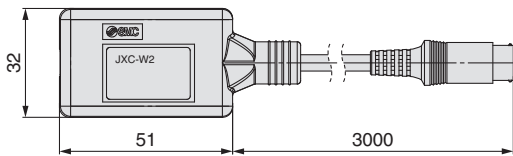

* It can be connected to the controller directly.

② USB cable JXC-W2-U

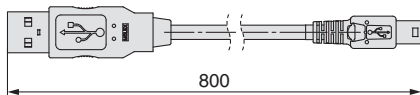

③ Controller setting software JXC-W2-S

* CD-ROM

■ DIN rail mounting adapter LEC-3-D0

* With 2 mounting screws

This should be used when a DIN rail mounting adapter is mounted onto a screw mounting type controller afterwards.

■ DIN rail AXT100-DR-□

* For □, enter a number from the No. line in the table on page 104. Refer to the dimension drawings on page 104 for the mounting dimensions.

■ Power supply plug JXC-CPW

* The power supply plug is an accessory.

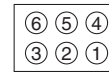
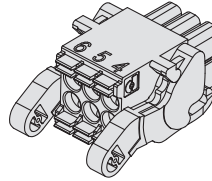

- ① C24V
- ② M24V
- ③ EMG
- ④ 0V
- ⑤ N.C.
- ⑥ LK RLS

Power supply plug

Terminal name	Function	Details
0V	Common supply (-)	M24V terminal/C24V terminal/EMG terminal/LK RLS terminal are common (-).
M24V	Motor power supply (+)	Motor power supply (+) of the controller
C24V	Control power supply (+)	Control power supply (+) of the controller
EMG	Stop (+)	Connection terminal of the external stop circuit
LK RLS	Lock release (+)	Connection terminal of the lock release switch

■ Communication plug connector

For DeviceNet™

Straight type
JXC-CD-S

T-branch type
JXC-CD-T

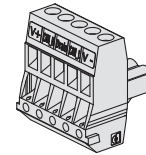
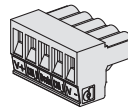

Communication plug connector for DeviceNet™

Terminal name	Details
V+	Power supply (+) for DeviceNet™
CAN_H	Communication wire (High)
Drain	Grounding wire/Shielded wire
CAN_L	Communication wire (Low)
V-	Power supply (-) for DeviceNet™

For IO-Link

Straight type
JXC-CL-S

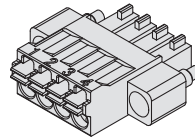

Communication plug connector for IO-Link

Terminal no.	Terminal name	Details
1	L+	+24 V
2	NC	N/A
3	L-	0 V
4	C/Q	IO-Link signal

■ Conversion cable P5062-5 (Cable length: 300 mm)

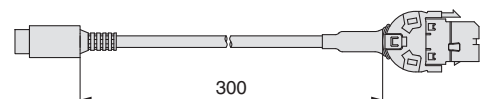

* To connect the teaching box (LEC-T1-3□G□) or controller setting kit (LEC-W2) to the controller, a conversion cable is required.



Series JXCE1/91/P1/D1 Precautions Related to Differences in Controller Versions

As the controller version of the JXC series differs, the internal parameters are not compatible.

- Do not use a version V2.0 or S2.0 or higher controller with parameters lower than version V2.0 or S2.0.
Do not use a version V2.0 or S2.0 or lower controller with parameters higher than version V2.0 or S2.0.
- Please use the latest version of the JXC-BCW (parameter writing tool).
* The latest version is Ver. 2.0 (as of December 2017).

Identifying Version Symbols



Version symbol

For versions lower than V2.0 and S2.0:

Do not use with controller parameters higher than V2.0 or S2.0.

VZ V1.8

Applicable models
Series JXC91□

VZ S1.3T1.0

Applicable models
Series JXCD1□
Series JXCP1□
Series JXCE1□

For versions higher than V2.0 and S2.0:

Do not use with controller parameters lower than V2.0 or S2.0.

VZ V2.0

Applicable models
Series JXC91□

VZ S2.0T1.0

Applicable models
Series JXCD1□
Series JXCP1□
Series JXCE1□

Model Selection

Servo Motor (24 VDC)/Step Motor (Servo/24 VDC)
LEY
LEYG

LECA6
LECP6

LEC-G

LECP1

LECPA

JXC□1

JXC7303/02/03

LEY

LEYG

LECS□

LECS-T

LECY□

Specific Product Precautions

Multi-Axis Step Motor Controller



- Speed tuning control *1
(3 Axes: JXC92 4 Axes: JXC73/83/93)
- Linear/circular interpolation

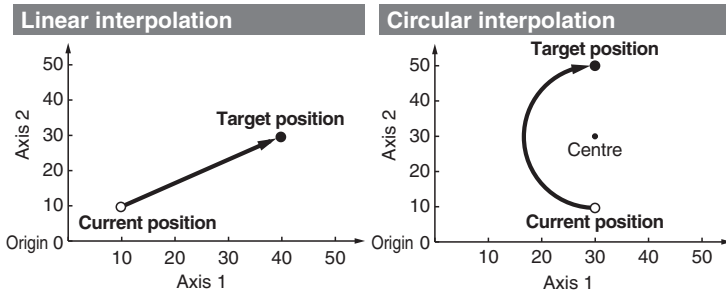

- Positioning/pushing operation
- Step data input
(Max. 2048 points)
- Space saving, reduced wiring
- Absolute/relative position coordinate instructions

*1 This controls the speed of the slave axis when the speed of the main axis drops due to the effects of an external force and when a speed difference with the slave axis occurs. This control is not for synchronising the position of the main axis and slave axis.

For 3 Axes Series JXC92

- EtherNet/IP™ Type
- Width: Approx. 38 % reduction

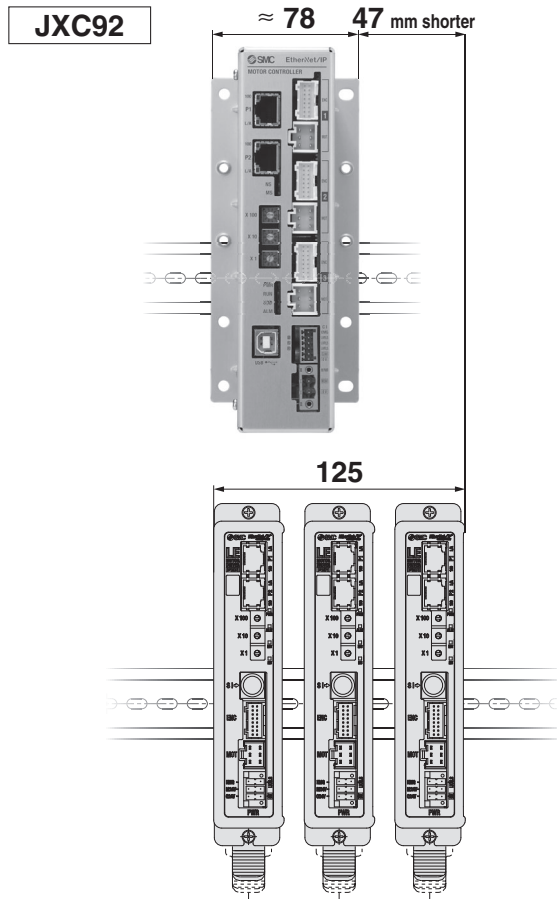

For 4 Axes Series JXC73/83/93

- Parallel I/O/
EtherNet/IP™ Type
- Width: Approx. 18 % reduction

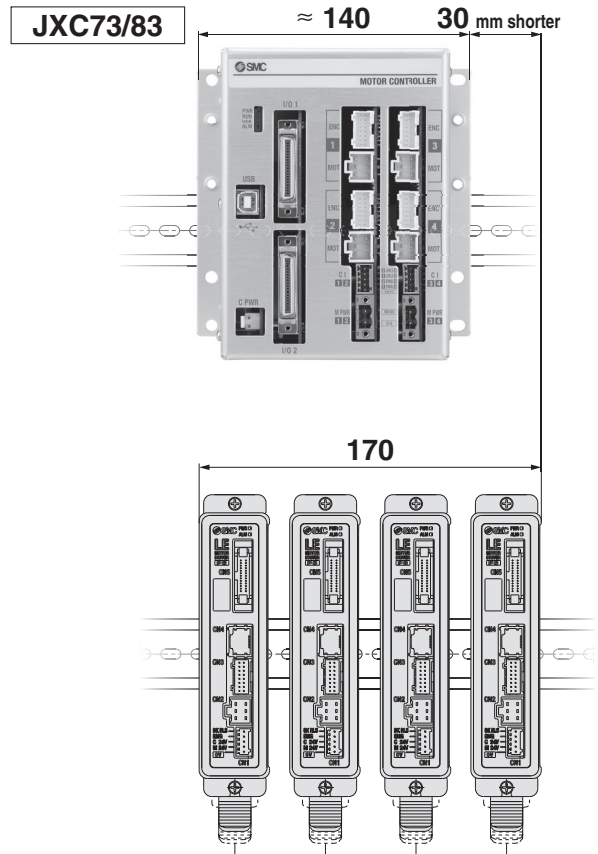

Series JXC73/83/92/93



* For LE□, size 25 or larger

Model Selection

LEY

LEYG

LECA6
LECP6

LEC-G

LECP1

LECPA

JXC□1

JXC73/83/92/93

LEY

LEYG

LECS□

LECS-T

LECY□

Specific Product Precautions

Series JXC73/83/92/93

Step Data Input: Max. 2048 points



For 3 Axes 3-axis operation can be set collectively in one step.

Step	Axis	Movement mode	Speed	Position	Acceleration	Deceleration	Pushing force	Trigger LV	Pushing speed	Moving force	Area 1	Area 2	In position	Comments
			mm/s	mm	mm/s ²	mm/s ²					mm	mm	mm	
0	Axis 1	ABS	500	100.00	3000	3000	0	85.0	50	100.0	10.0	30.0	0.5	
	Axis 2	ABS	500	100.00	3000	3000	0	85.0	50	100.0	10.0	30.0	0.5	
	Axis 3	ABS	500	100.00	3000	3000	0	85.0	50	100.0	10.0	30.0	0.5	
1	Axis 1	INC	500	200.00	3000	3000	0	85.0	50	100.0	0	0	0.5	
	Axis 2	INC	500	200.00	3000	3000	0	85.0	50	100.0	0	0	0.5	
	Axis 3	INC	500	200.00	3000	3000	0	85.0	50	100.0	0	0	0.5	
2046	Axis 1	SYN-I	500	100.00	3000	3000	0	0	0	100.0	0	0	0.5	
	Axis 2	SYN-I	0	0.00	0	0	0	0	0	100.0	0	0	0.5	
	Axis 3	SYN-I	0	0.00	0	0	0	0	0	100.0	0	0	0.5	
2047	Axis 1	CIR-R	500	0.00	3000	3000	0	0	0	100.0	0	0	0.5	
	Axis 2	CIR-R	0	50.00	0	0	0	0	0	100.0	0	0	0.5	
	Axis 3 *1		0	0.00	0	0	0	0	0	100.0	0	0	0.5	
	Axis 4 *1		0	25.00	0	0	0	0	0	100.0	0	0	0.5	

*1 When circular interpolation (CIR-R, CIR-L, CIR-3) is selected in the movement mode, input the X and Y coordinates in the rotation centre position or input the X and Y coordinates in the passing position.

Movement mode	Pushing operation	Details
Blank	×	Invalid data (Invalid process)
ABS	○	Moves to the absolute coordinate position based on the origin of the actuator
INC	○	Moves to the relative coordinate position based on the current position
LIN-A	×	Moves to the absolute coordinate position based on the origin of the actuator by linear interpolation
LIN-I	×	Moves to the relative coordinate position based on the current position by linear interpolation
CIR-R*2	×	With Axis 1 assigned to the X-axis and Axis 2 to the Y-axis, it moves in the clockwise direction by circular interpolation. The target position and rotation centre position are specified according to the relative coordinates from the current position. The position data is assigned as follows. Axis 1: Target position X Axis 2: Target position Y Axis 3 *1: Rotation centre position X Axis 4 *1: Rotation centre position Y
CIR-L*2	×	With Axis 1 assigned to the X-axis and Axis 2 to the Y-axis, it moves in the counter-clockwise direction by circular interpolation. The target position and rotation centre position are specified according to the relative coordinates from the current position. The position data is assigned as follows. Axis 1: Target position X Axis 2: Target position Y Axis 3 *1: Rotation centre position X Axis 4 *1: Rotation centre position Y
SYN-I	×	Moves to the relative coordinate position based on the current position by speed tuning control *3
CIR-3*2	×	With Axis 1 assigned to the X-axis and Axis 2 to the Y-axis, it moves based on the three specified points by circular interpolation. The target position and passing position are specified according to the relative coordinates from the current position. The position data is assigned as follows. Axis 1: Target position X Axis 2: Target position Y Axis 3 *1: Passing position X Axis 4 *1: Passing position Y

*2 Performs a circular operation on a plane using Axis 1 and Axis 2

*3 This controls the speed of the slave axis when the speed of the main axis drops due to the effects of an external force and when a speed difference with the slave axis occurs. This control is not for synchronising the position of the main axis and slave axis.

Multi-Axis Step Motor Controller Series JXC73/83/92/93



For 4 Axes 4-axis operation can be set collectively in one step.

Step	Axis	Movement mode	Speed	Position	Acceleration	Deceleration	Positioning/ Pushing	Area 1	Area 2	In position	Comments
			mm/s	mm	mm/s ²	mm/s ²		mm	mm	mm	
0	Axis 1	ABS	100	200.00	1000	1000	0	6.0	12.0	0.5	
	Axis 2	ABS	50	100.00	1000	1000	0	6.0	12.0	0.5	
	Axis 3	ABS	50	100.00	1000	1000	0	6.0	12.0	0.5	
	Axis 4	ABS	50	100.00	1000	1000	0	6.0	12.0	0.5	
1	Axis 1	INC	500	250.00	1000	1000	1	0	0	20.0	
	Axis 2	INC	500	250.00	1000	1000	1	0	0	20.0	
	Axis 3	INC	500	250.00	1000	1000	1	0	0	20.0	
	Axis 4	INC	500	250.00	1000	1000	1	0	0	20.0	
...	
2046	Axis 4	ABS	200	700	500	500	0	0	0	0.5	
2047	Axis 1	ABS	500	0.00	3000	3000	0	0	0	0.5	
	Axis 2	ABS	500	0.00	3000	3000	0	0	0	0.5	
	Axis 3	ABS	500	0.00	3000	3000	0	0	0	0.5	
	Axis 4	ABS	500	0.00	3000	3000	0	0	0	0.5	

Movement mode	Pushing operation	Details
Blank	×	Invalid data (Invalid process)
ABS	○	Moves to the absolute coordinate position based on the origin of the actuator
INC	○	Moves to the relative coordinate position based on the current position
LIN-A	×	Moves to the absolute coordinate position based on the origin of the actuator by linear interpolation
LIN-I	×	Moves to the relative coordinate position based on the current position by linear interpolation
CIR-R*1	×	With Axis 1 assigned to the X-axis and Axis 2 to the Y-axis, it moves in the clockwise direction by circular interpolation. The target position and rotation centre position are specified according to the relative coordinates from the current position. The position data is assigned as follows. Axis 1: Target position X Axis 2: Target position Y Axis 3: Rotation centre position X Axis 4: Rotation centre position Y
CIR-L*1	×	With Axis 1 assigned to the X-axis and Axis 2 to the Y-axis, it moves in the counter-clockwise direction by circular interpolation. The target position and rotation centre position are specified according to the relative coordinates from the current position. The position data is assigned as follows. Axis 1: Target position X Axis 2: Target position Y Axis 3: Rotation centre position X Axis 4: Rotation centre position Y
SYN-I	×	Moves to the relative coordinate position based on the current position by speed tuning control *2

*1 Performs a circular operation on a plane using Axis 1 and Axis 2

*2 This controls the speed of the slave axis when the speed of the main axis drops due to the effects of an external force and when a speed difference with the slave axis occurs. This control is not for synchronising the position of the main axis and slave axis.

Model Selection

LEY

LEYG

LECA6
LECP6

LEC-G

LECP1

LECPA

JXC□1

JXC73/83/92/93

LEY

LEYG

LECS□

LECS-T

LECY□

Specific Product Precautions

For 3 Axes System Construction/EtherNet/IP™ Type (JXC92)

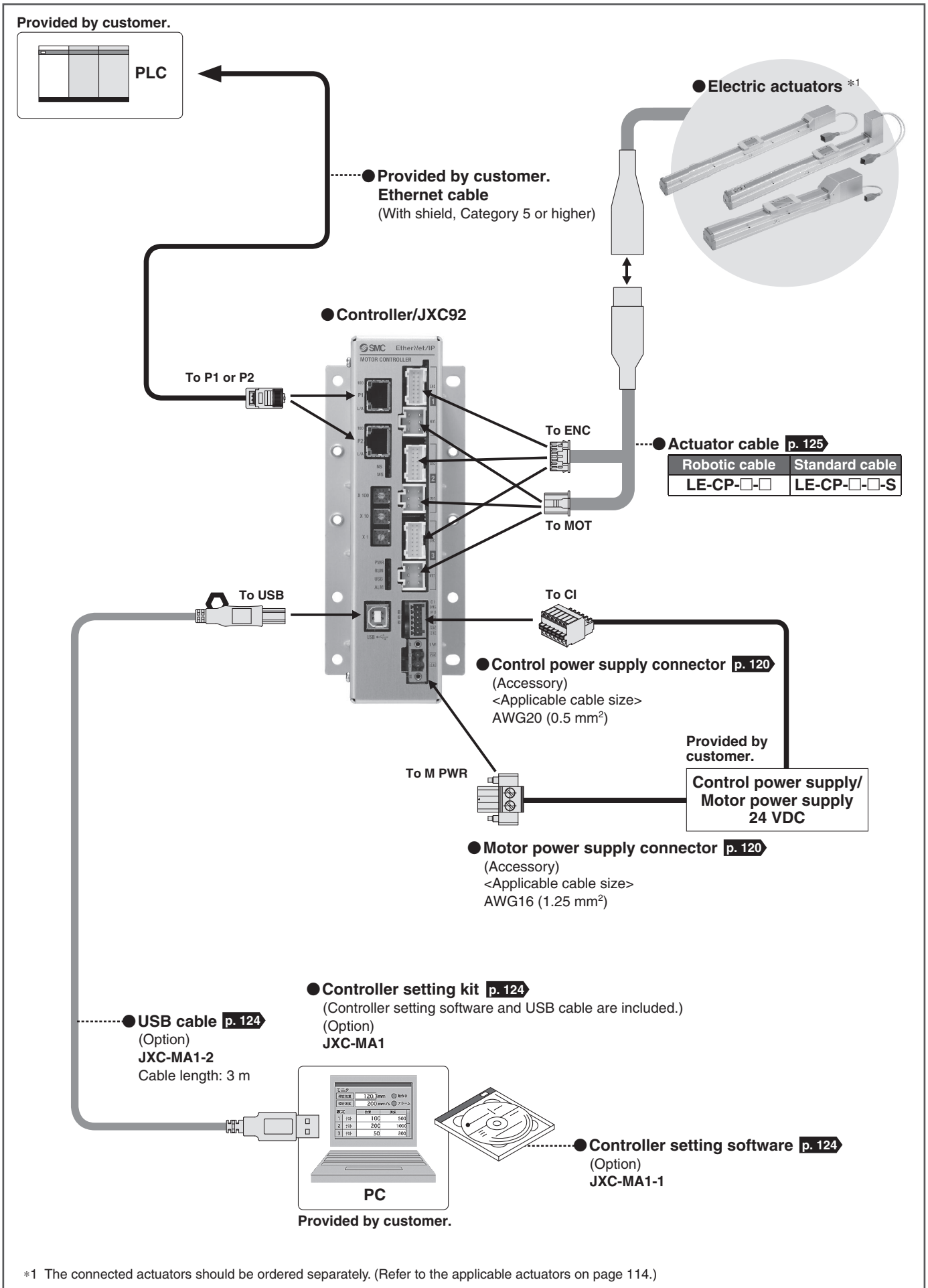

*1 The connected actuators should be ordered separately. (Refer to the applicable actuators on page 114.)

For 4 Axes System Construction/Parallel I/O (JXC73/83)

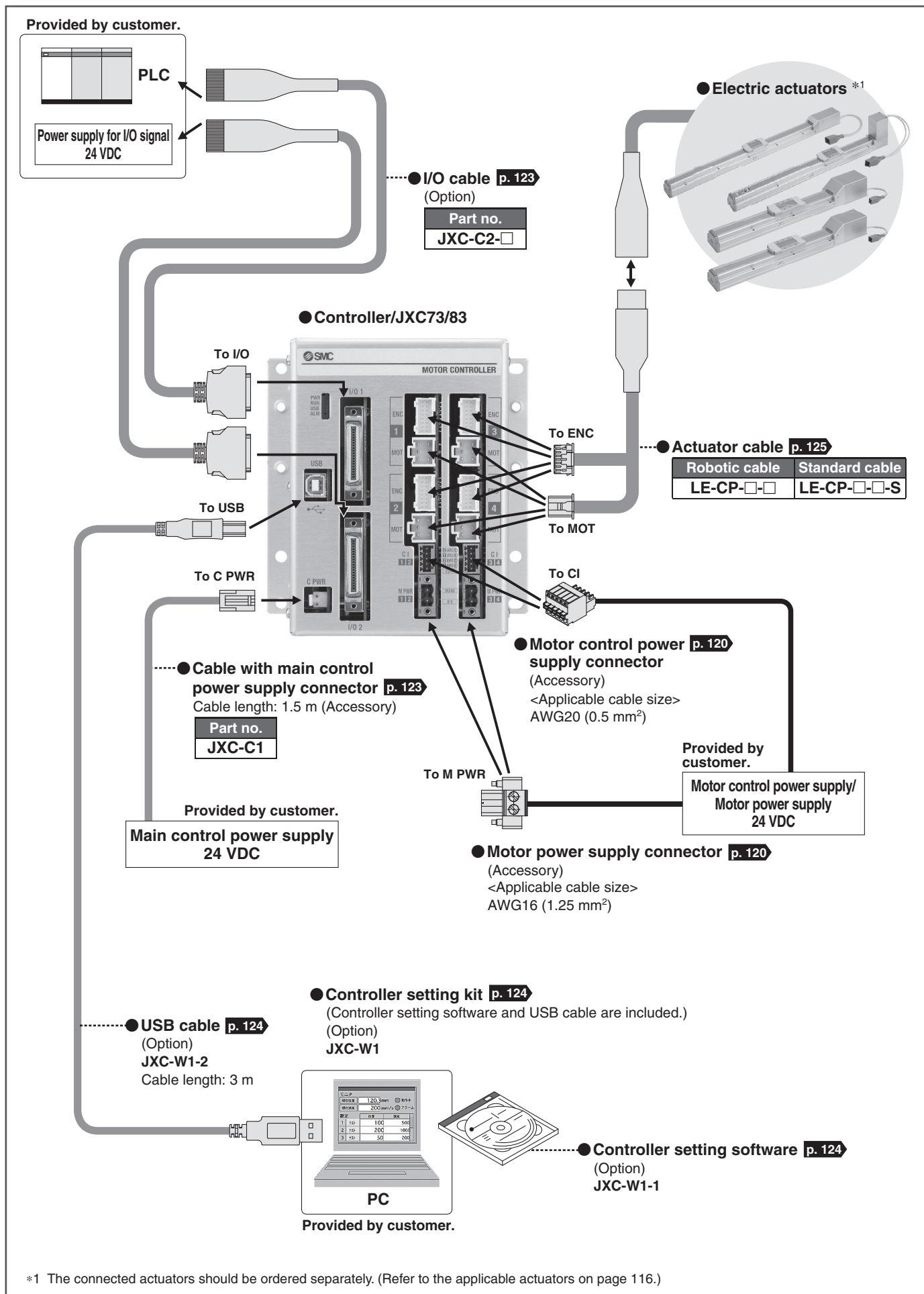

*1 The connected actuators should be ordered separately. (Refer to the applicable actuators on page 116.)

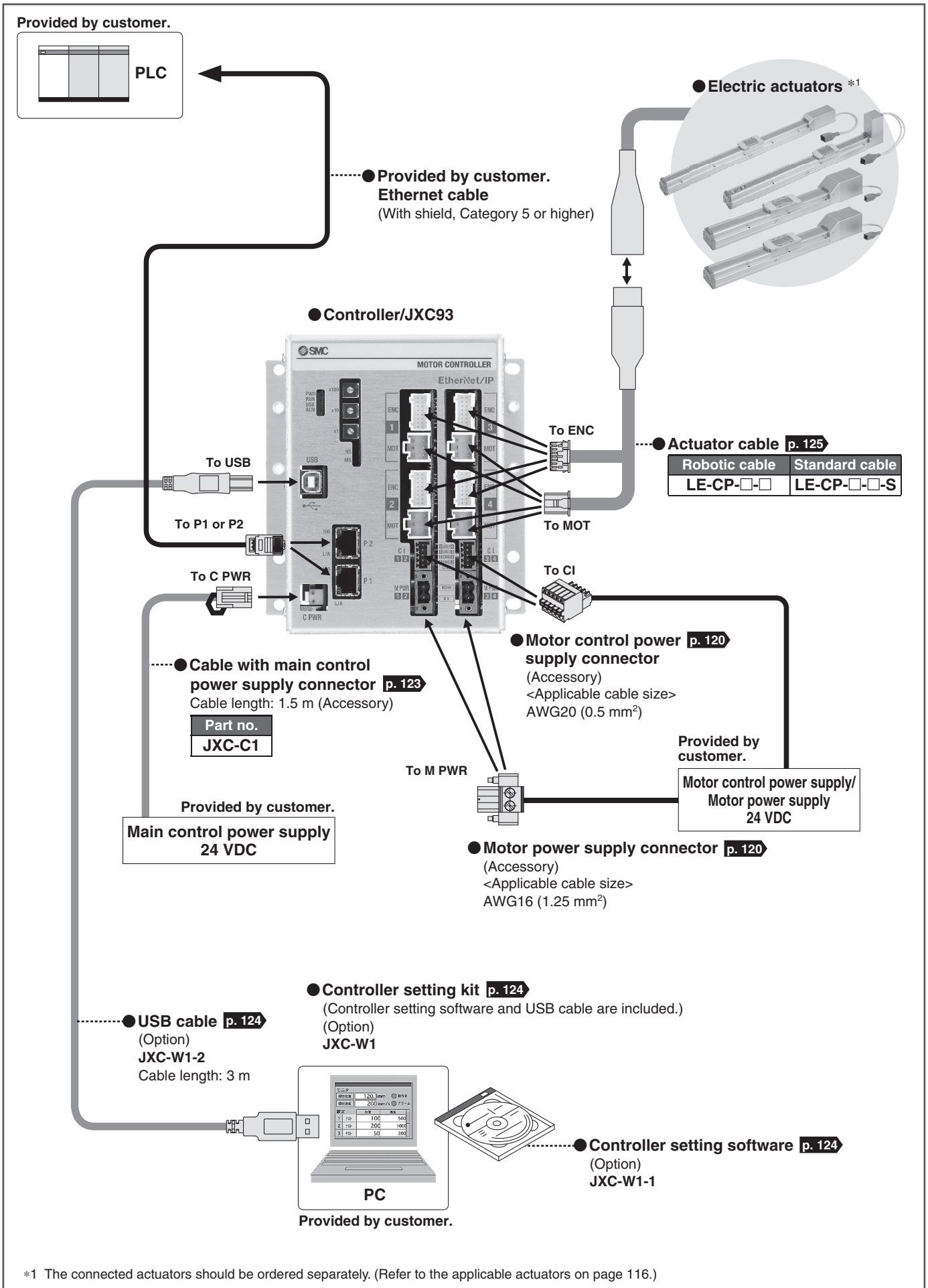

*1 The connected actuators should be ordered separately. (Refer to the applicable actuators on page 116.)

3-Axis Step Motor Controller (EtherNet/IP™ Type)

Series JXC92



How to Order

■ EtherNet/IP™ Type (JXC92)

Controller



JXC 9 2 7

EtherNet/IP™ type

3-axis type

● Mounting

Symbol	Mounting
7	Screw mounting
8	DIN rail

Applicable Actuators

Applicable actuators		Refer to the Web Catalogue.
Electric Actuator/Rod	Series LEY	
Electric Actuator/Guide Rod	Series LEYG	
Electric Actuator/Slider	Series LEF	
Electric Slide Table	Series LES/LESH	
Electric Rotary Table	Series LER	
Electric Actuator/Miniature	Series LEPY/LEPS	
Electric Gripper (2-Finger Type, 3-Finger Type)	Series LEH	

* Order the actuator separately, including the actuator cable.
(Example: LEFS16B-100B-S1)

* For the "Speed-Work Load" graph of the actuator, refer to the LECPA section on the model selection page of the electric actuators Web Catalogue.

Specifications

For the setting of functions and operation methods, refer to the operation manual on the SMC website. (Documents/Download --> Instruction Manuals)

EtherNet/IP™ Type (JXC92)

Item	Specifications	
Number of axes	Max. 3 axes	
Compatible motor	Step motor (Servo/24 VDC)	
Compatible encoder	Incremental A/B phase (Encoder resolution: 800 pulse/rotation)	
Power supply *1	Control power supply Power voltage: 24 VDC ±10 % Max. current consumption: 500 mA Motor power supply Power voltage: 24 VDC ±10 % Max. current consumption: Based on the connected actuator *2	
Communication	Protocol	EtherNet/IP™ *3
	Communication speed	10 Mbps/100 Mbps (automatic negotiation)
	Communication method	Full duplex/Half duplex (automatic negotiation)
	Configuration file	EDS file
	Occupied area	Input 16 bytes/Output 16 bytes
	IP address setting range	Manual setting by switches: From 192.168.1.1 to 254, Via DHCP server: Arbitrary address
	Vendor ID	7 h (SMC Corporation)
Product type	2 Bh (Generic Device)	
Product code	DEh	
Serial communication	USB2.0 (Full Speed 12 Mbps)	
Memory	Flash-ROM	
LED indicator	PWR, RUN, USB, ALM, NS, MS, L/A, 100	
Lock control	Forced-lock release terminal *4	
Cable length	Actuator cable: 20 m or less	
Cooling system	Natural air cooling	
Operating temperature range	0 °C to 40 °C (No freezing)	
Operating humidity range	90 % RH or less (No condensation)	
Storage temperature range	-10 °C to 60 °C (No freezing)	
Storage humidity range	90 % RH or less (No condensation)	
Insulation resistance	Between all external terminals and the case: 50 MΩ (500 VDC)	
Weight	600 g (Screw mounting), 650 g (DIN rail mounting)	

*1 Do not use a power supply with inrush current protection for the motor drive power supply.

*2 Power consumption depends on the actuator connected. Refer to the actuator specifications for further details.

*3 EtherNet/IP™ is a trademark of ODA.

*4 Applicable to non-magnetising locks

Model Selection

LEYG

LEYG

LECA6

LECP6

LEC-G

LECP1

LECPA

JXC□1

JXC7□□□□□□□□

AC Servo Motor

LEY

LEYG

LECS□

LECS-T

LECY□

Specific Product Precautions

Series JXC92

Dimensions

EtherNet/IP™ Type JXC92

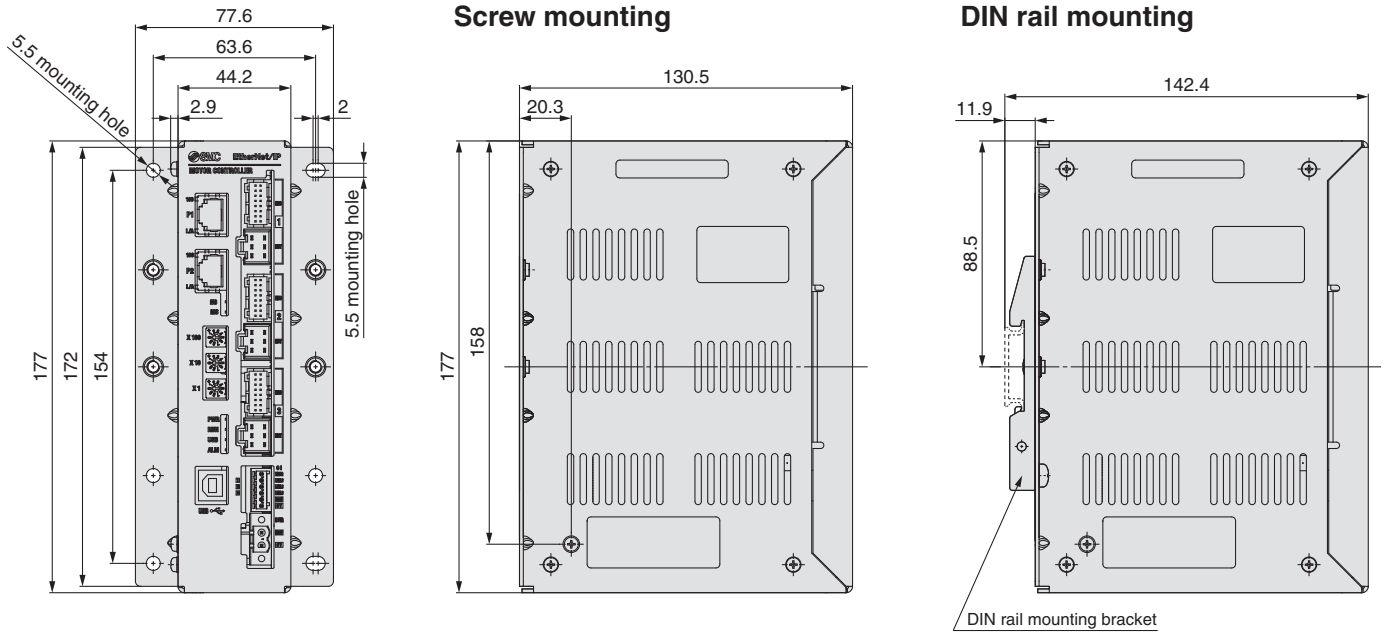

Controller Details

EtherNet/IP™ Type JXC92

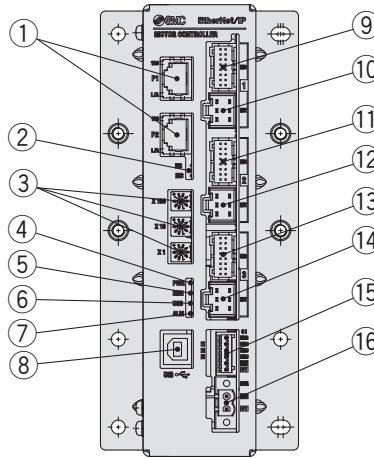

No.	Name	Description	Details
①	P1, P2	EtherNet/IP™ communication connector	Connect Ethernet cable.
②	NS, MS	Communication status LED	Displays the status of the EtherNet/IP™ communication
③	X100 X10 X1	IP address setting switches	Switch to set the 4th byte of the IP address by X1, X10 and X100.
④	PWR	Power supply LED (Green)	Power supply ON: Green turns on Power supply OFF: Green turns off
⑤	RUN	Operation LED (Green)	Running in EtherNet/IP™: Green turns on Running via USB communication: Green flashes Stopped: Green turns off
⑥	USB	USB connection LED (Green)	USB connected: Green turns on USB not connected: Green turns off
⑦	ALM	Alarm LED (Red)	With alarm: Red turns on Without alarm: Red turns off
⑧	USB	Serial communication connector	Connect to a PC via the USB cable.
⑨	ENC ①	Encoder connector (16 pins)	Axis 1: Connect the actuator cable.
⑩	MOT ①	Motor power connector (6 pins)	
⑪	ENC ②	Encoder connector (16 pins)	
⑫	MOT ②	Motor power connector (6 pins)	Axis 2: Connect the actuator cable.
⑬	ENC ③	Encoder connector (16 pins)	
⑭	MOT ③	Motor power connector (6 pins)	Axis 3: Connect the actuator cable.
⑮	CI	Control power supply connector *1	Control power supply (+), All axes stop (+), Axis 1 lock release (+), Axis 2 lock release (+), Axis 3 lock release (+), Common (-)
⑯	M PWR	Motor power supply connector *1	Motor power supply (+), Motor power supply (-)

*1 Connectors are included. (Refer to page 120.)

4-Axis Step Motor Controller (Parallel I/O/EtherNet/IP™ Type)

Series JXC73/83/93



How to Order

Parallel I/O (JXC73/83)

Controller



JXC 8 3 2

I/O type

Symbol	I/O type
7	NPN
8	PNP

I/O cable, mounting

Symbol	I/O cable	Mounting
1	1.5 m	Screw mounting
2	1.5 m	DIN rail
3	3 m	Screw mounting
4	3 m	DIN rail
5	5 m	Screw mounting
6	5 m	DIN rail
7	None	Screw mounting
8	None	DIN rail

4-axis type

* Two I/O cables are included.

EtherNet/IP™ Type (JXC93)

Controller

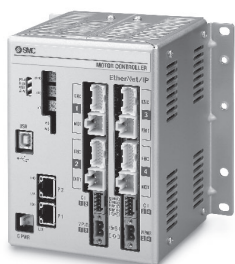

JXC 9 3 8

EtherNet/IP™ type

Mounting

Symbol	Mounting
7	Screw mounting
8	DIN rail

4-axis type

Applicable Actuators

Applicable actuators	
Electric Actuator/Rod Series LEY	Refer to the Web Catalogue.
Electric Actuator/Guide Rod Series LEYG	
Electric Actuator/Slider Series LEF	
Electric Slide Table Series LES/LESH	
Electric Rotary Table Series LER *1	
Electric Actuator/Miniature Series LEPY/LEPS	
Electric Gripper (2-Finger Type, 3-Finger Type) Series LEH	

*1 Except the continuous rotation (360°) specification.

* Order the actuator separately, including the actuator cable.
(Example: LEFS16B-100B-S1)

* For the "Speed-Work Load" graph of the actuator, refer to the LECPA section on the model selection page of the electric actuators Web Catalogue.

Model Selection

LEY

LEYG

LECA6
LECP6

LEC-G

LECP1

LECPA

JXC□1

JXC73/83/93

LEY

LEYG

LECS□

LECS-T

LECY□

Specific Product Precautions

Series JXC73/83/93

Specifications

For the setting of functions and operation methods, refer to the operation manual on the SMC website. (Documents/Download --> Instruction Manuals)

Parallel I/O (JXC73/83)

Item	Specifications
Number of axes	Max. 4 axes
Compatible motor	Step motor (Servo/24 VDC)
Compatible encoder	Incremental A/B phase (Encoder resolution: 800 pulse/rotation)
Power supply *1	Main control power supply Power voltage: 24 VDC ±10 % Max. current consumption: 300 mA Motor power supply, Motor control power supply (Common) Power voltage: 24 VDC ±10 % Max. current consumption: Based on the connected actuator *2
Parallel input	16 inputs (Photo-coupler isolation)
Parallel output	32 outputs (Photo-coupler isolation)
Serial communication	USB2.0 (Full Speed 12 Mbps)
Memory	Flash-ROM/EEPROM
LED indicator	PWR, RUN, USB, ALM
Lock control	Forced-lock release terminal *3
Cable length	I/O cable: 5 m or less, Actuator cable: 20 m or less
Cooling system	Natural air cooling
Operating temperature range	0 °C to 40 °C (No freezing)
Operating humidity range	90 % RH or less (No condensation)
Storage temperature range	-10 °C to 60 °C (No freezing)
Storage humidity range	90 % RH or less (No condensation)
Insulation resistance	Between all external terminals and the case: 50 MΩ (500 VDC)
Weight	1050 g (Screw mounting), 1100 g (DIN rail mounting)

*1 Do not use a power supply with inrush current protection for the motor drive power and motor control power supply.

*2 Power consumption depends on the actuator connected. Refer to the actuator specifications for further details.

*3 Applicable to non-magnetising locks

For the setting of functions and operation methods, refer to the operation manual on the SMC website. (Documents/Download --> Instruction Manuals)

EtherNet/IP™ Type (JXC93)

Item	Specifications	
Number of axes	Max. 4 axes	
Compatible motor	Step motor (Servo/24 VDC)	
Compatible encoder	Incremental A/B phase (Encoder resolution: 800 pulse/rotation)	
Power supply *1	Main control power supply Power voltage: 24 VDC ±10 % Max. current consumption: 350 mA Motor power supply, Motor control power supply (Common) Power voltage: 24 VDC ±10 % Max. current consumption: Based on the connected actuator *2	
Communication	Protocol	EtherNet/IP™ *4
	Communication speed	10 Mbps/100 Mbps (automatic negotiation)
	Communication method	Full duplex/Half duplex (automatic negotiation)
	Configuration file	EDS file
	Occupied area	Input 16 bytes/Output 16 bytes
	IP address setting range	Manual setting by switches: From 192.168.1.1 to 254, Via DHCP server: Arbitrary address
	Vendor ID	7 h (SMC Corporation)
	Product type	2 Bh (Generic Device)
	Product code	DCh
Serial communication	USB2.0 (Full Speed 12 Mbps)	
Memory	Flash-ROM/EEPROM	
LED indicator	PWR, RUN, USB, ALM, NS, MS, L/A, 100	
Lock control	Forced-lock release terminal *3	
Cable length	Actuator cable: 20 m or less	
Cooling system	Natural air cooling	
Operating temperature range	0 °C to 40 °C (No freezing)	
Operating humidity range	90 % RH or less (No condensation)	
Storage temperature range	-10 °C to 60 °C (No freezing)	
Storage humidity range	90 % RH or less (No condensation)	
Insulation resistance	Between all external terminals and the case: 50 MΩ (500 VDC)	
Weight	1050 g (Screw mounting), 1100 g (DIN rail mounting)	

*1 Do not use a power supply with inrush current protection for the motor drive power and motor control power supply.

*2 Power consumption depends on the actuator connected. Refer to the actuator specifications for further details.

*3 Applicable to non-magnetising locks

*4 EtherNet/IP™ is a trademark of ODVA.

Series JXC73/83/93

Controller Details

Parallel I/O JXC73/83

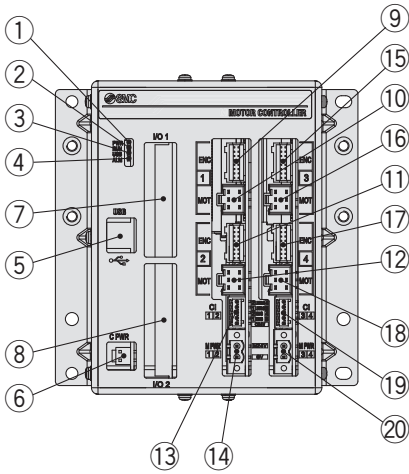

No.	Name	Description	Details
①	PWR	Power supply LED (Green)	Power supply ON: Green turns on Power supply OFF: Green turns off
②	RUN	Operation LED (Green)	Running in parallel I/O: Green turns on Running via USB communication: Green flashes Stopped: Green turns off
③	USB	USB connection LED (Green)	USB connected: Green turns on USB not connected: Green turns off
④	ALM	Alarm LED (Red)	With alarm: Red turns on Without alarm: Red turns off
⑤	USB	Serial communication	Connect to a PC via the USB cable.
⑥	C PWR	Main control power supply connector (2 pins) *1	Main control power supply (+) (-)
⑦	I/O 1	Parallel I/O connector (40 pins)	Connect to a PLC via the I/O cable.
⑧	I/O 2	Parallel I/O connector (40 pins)	Connect to a PLC via the I/O cable.
⑨	ENC 1	Encoder connector (16 pins)	Axis 1: Connect the actuator cable.
⑩	MOT 1	Motor power connector (6 pins)	
⑪	ENC 2	Encoder connector (16 pins)	Axis 2: Connect the actuator cable.
⑫	MOT 2	Motor power connector (6 pins)	
⑬	CI 1 2	Motor control power supply connector *1	Motor control power supply (+), Axis 1 stop (+), Axis 1 lock release (+), Axis 2 stop (+), Axis 2 lock release (+)
⑭	M PWR 1 2	Motor power supply connector *1	For Axis 1, 2. Motor power supply (+), Common (-)
⑮	ENC 3	Encoder connector (16 pins)	Axis 3: Connect the actuator cable.
⑯	MOT 3	Motor power connector (6 pins)	
⑰	ENC 4	Encoder connector (16 pins)	Axis 4: Connect the actuator cable.
⑱	MOT 4	Motor power connector (6 pins)	
⑲	CI 3 4	Motor control power supply connector *1	Motor control power supply (+), Axis 3 stop (+), Axis 3 lock release (+), Axis 4 stop (+), Axis 4 lock release (+)
⑳	M PWR 3 4	Motor power supply connector *1	For Axis 3, 4. Motor power supply (+), Common (-)

*1 Connectors are included. (Refer to page 120.)

EtherNet/IP™ Type JXC93

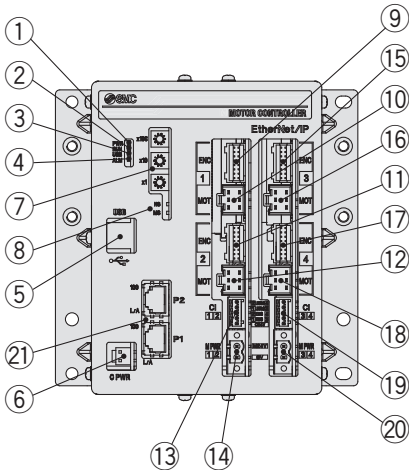

No.	Name	Description	Details
①	PWR	Power supply LED (Green)	Power supply ON: Green turns on Power supply OFF: Green turns off
②	RUN	Operation LED (Green)	Running in EtherNet/IP™: Green turns on Running via USB communication: Green flashes Stopped: Green turns off
③	USB	USB connection LED (Green)	USB connected: Green turns on USB not connected: Green turns off
④	ALM	Alarm LED (Red)	With alarm: Red turns on Without alarm: Red turns off
⑤	USB	Serial communication	Connect to a PC via the USB cable.
⑥	C PWR	Main control power supply connector (2 pins) *1	Main control power supply (+) (-)
⑦	x100 x10 x1	IP address setting switches	Switch to set the 4th byte of the IP address by X1, X10 and X100.
⑧	MS, NS	Communication status LED	Displays the status of the EtherNet/IP™ communication
⑨	ENC 1	Encoder connector (16 pins)	Axis 1: Connect the actuator cable.
⑩	MOT 1	Motor power connector (6 pins)	
⑪	ENC 2	Encoder connector (16 pins)	Axis 2: Connect the actuator cable.
⑫	MOT 2	Motor power connector (6 pins)	
⑬	CI 1 2	Motor control power supply connector *1	Motor control power supply (+), Axis 1 stop (+), Axis 1 lock release (+), Axis 2 stop (+), Axis 2 lock release (+)
⑭	M PWR 1 2	Motor power supply connector *1	For Axis 1, 2. Motor power supply (+), Common (-)
⑮	ENC 3	Encoder connector (16 pins)	Axis 3: Connect the actuator cable.
⑯	MOT 3	Motor power connector (6 pins)	
⑰	ENC 4	Encoder connector (16 pins)	Axis 4: Connect the actuator cable.
⑱	MOT 4	Motor power connector (6 pins)	
⑲	CI 3 4	Motor control power supply connector *1	Motor control power supply (+), Axis 3 stop (+), Axis 3 lock release (+), Axis 4 stop (+), Axis 4 lock release (+)
⑳	M PWR 3 4	Motor power supply connector *1	For Axis 3, 4. Motor power supply (+), Common (-)
㉑	P1, P2	EtherNet/IP™ communication connector	Connect Ethernet cable.

*1 Connectors are included. (Refer to page 120.)

Wiring Example 1

Cable with Main Control Power Supply Connector (For 4 Axes)*1: C PWR 1 pc. For 4 Axes
JXC73/83/93

Terminal name	Function	Details
+24V	Main control power supply (+)	Power supply (+) supplied to the main control
24-0V	Main control power supply (-)	Power supply (-) supplied to the main control

*1 Part no.: JXC-C1 (Cable length: 1.5 m)

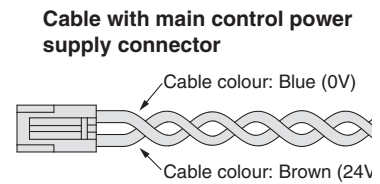

Motor Power Supply Connector (For 3/4 Axes)*2: M PWR 2 pcs.*3 For 3 Axes
JXC92 For 4 Axes
JXC73/83/93

Terminal name	Function	Details	Note
0V	Motor power supply (-)	Power supply (-) supplied to the motor power	For 3 axes JXC92
M 24V		The M 24V terminal, C 24V terminal, EMG terminal, and LKRLS terminal are common (-).	For 4 axes JXC73/83/93
M 24V	Motor power supply (+)	Power supply (+) supplied to the motor power	

*2 Manufactured by PHOENIX CONTACT (Part no.: MSTB2, 5/2-STF-5, 08)

*3 1 pc. for 3 axes (JXC92)

Motor power supply connector

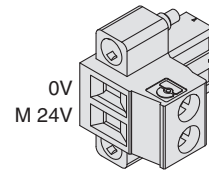

Motor Control Power Supply Connector (For 4 Axes)*4: CI 2 pcs. For 4 Axes
JXC73/83/93

Terminal name	Function	Details
C 24V	Motor control power supply (+)	Power supply (+) supplied to the motor control
EMG1/EMG3	Stop (+)	Axis 1/Axis 3: Input (+) for releasing the stop
EMG2/EMG4	Stop (+)	Axis 2/Axis 4: Input (+) for releasing the stop
LKRLS1/LKRLS3	Lock release (+)	Axis 1/Axis 3: Input (+) for releasing the lock
LKRLS2/LKRLS4	Lock release (+)	Axis 2/Axis 4: Input (+) for releasing the lock

*4 Manufactured by PHOENIX CONTACT (Part no.: FK-MC0, 5/5-ST-2, 5)

Motor control power supply connector

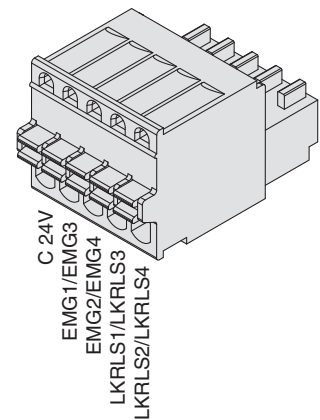

Control Power Supply Connector (For 3 Axes)*5: CI 1 pc. For 3 Axes
JXC92

Terminal name	Function	Details
0V	Control power supply (-)	The C 24V terminal, LKRLS terminal, and EMG terminal are common (-).
C 24V	Control power supply (+)	Power supply (+) supplied to the control
LKRLS3	Lock release (+)	Axis 3: Input (+) for releasing the lock
LKRLS2	Lock release (+)	Axis 2: Input (+) for releasing the lock
LKRLS1	Lock release (+)	Axis 1: Input (+) for releasing the lock
EMG	Stop (+)	All axes: Input (+) for releasing the stop

*5 Manufactured by PHOENIX CONTACT (Part no.: FK-MC0, 5/6-ST-2, 5)

Control power supply connector

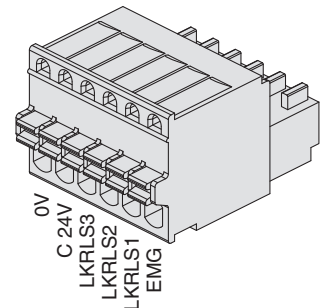

Model Selection

Servo Motor (24 VDC) / Step Motor (Servo/24 VDC)
LEY
LEYG

LECA6
LECP6

LEC-G
LECP1

LECPA
LECP1

JXC01

JXC73/83/92/93

AC Servo Motor
LEY
LEYG

LECS
LECS-T

LECY

Specific Product Precautions

Series JXC73/83/92/93

Wiring Example 2

Parallel I/O Connector

- * When you connect a PLC to the I/O 1 or I/O 2 parallel I/O connector, use the I/O cable (JXC-C2-□).
- * The wiring changes depending on the type of the parallel I/O (NPN or PNP).

I/O 1 Wiring example

NPN JXC73

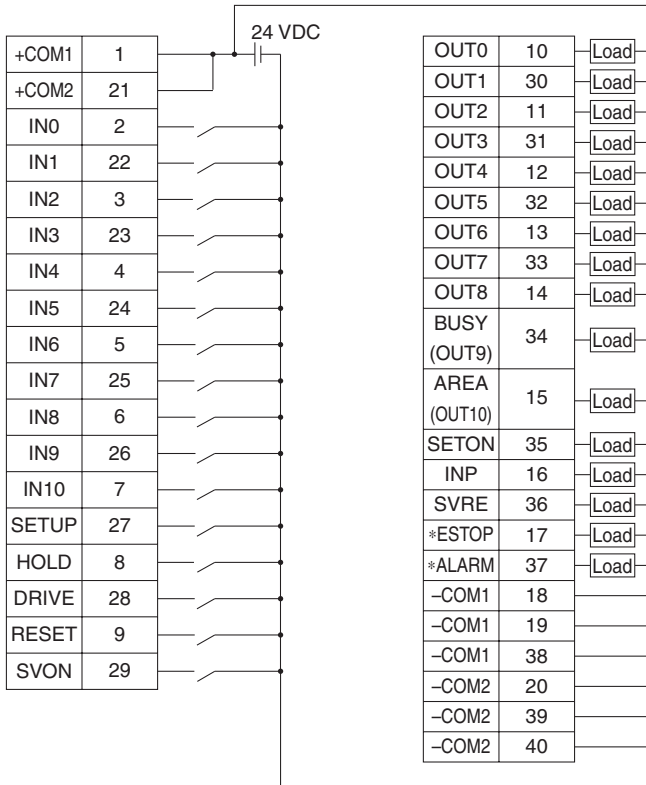

PNP JXC83

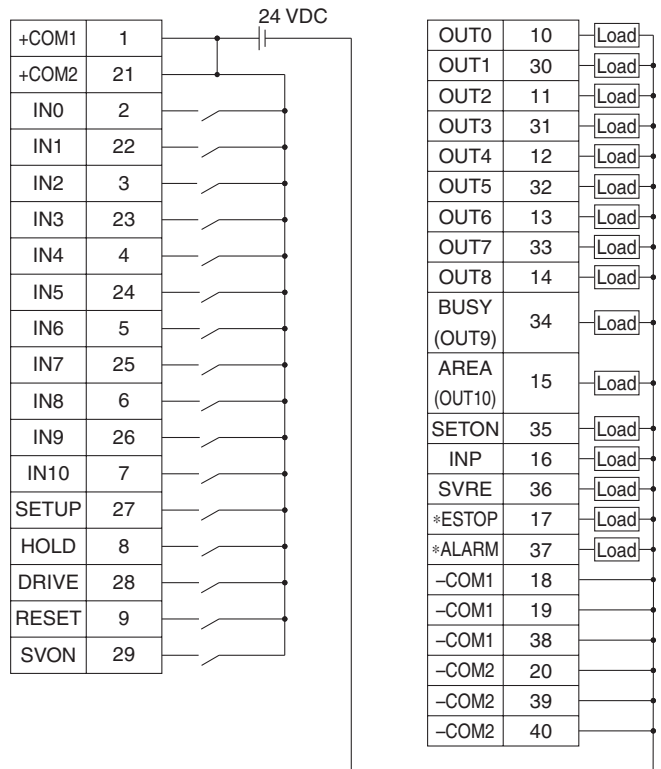

I/O 1 Input Signal

Name	Details
+COM1 +COM2	Connects the power supply 24 V for input/output signal
IN0 to IN8	Step data specified Bit No. (Standard: When 512 points are used)
IN9 IN10	Step data specified extension Bit No. (Extension: When 2048 points are used)
SETUP	Instruction to return to origin
HOLD	Operation is temporarily stopped
DRIVE	Instruction to drive
RESET	Alarm reset and operation interruption
SVON	Servo ON instruction

I/O 1 Output Signal

Name	Details
OUT0 to OUT8	Outputs the step data no. during operation
BUSY (OUT9)	Outputs when the operation of the actuator is in progress
AREA (OUT10)	Outputs when all actuators are within the area output range
SETON	Outputs when the return to origin of all actuators is completed
INP	Outputs when the positioning or pushing of all actuators is completed
SVRE	Outputs when servo is ON
*ESTOP *1	Not output when EMG stop is instructed
*ALARM *1	Not output when alarm is generated
-COM1 -COM2	Connects the power supply 0 V for input/output signal

*1 Negative-logic circuit signal

Wiring Example 2

Parallel I/O Connector

- * When you connect a PLC to the I/O 1 or I/O 2 parallel I/O connector, use the I/O cable (JXC-C2-□).
- * The wiring changes depending on the type of the parallel I/O (NPN or PNP).

I/O 2 Wiring example

NPN JXC73

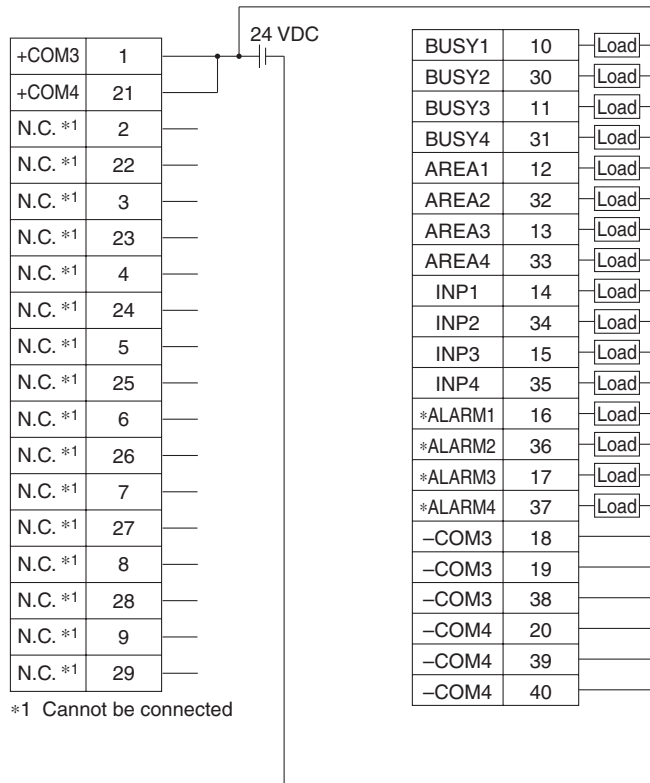

PNP JXC83

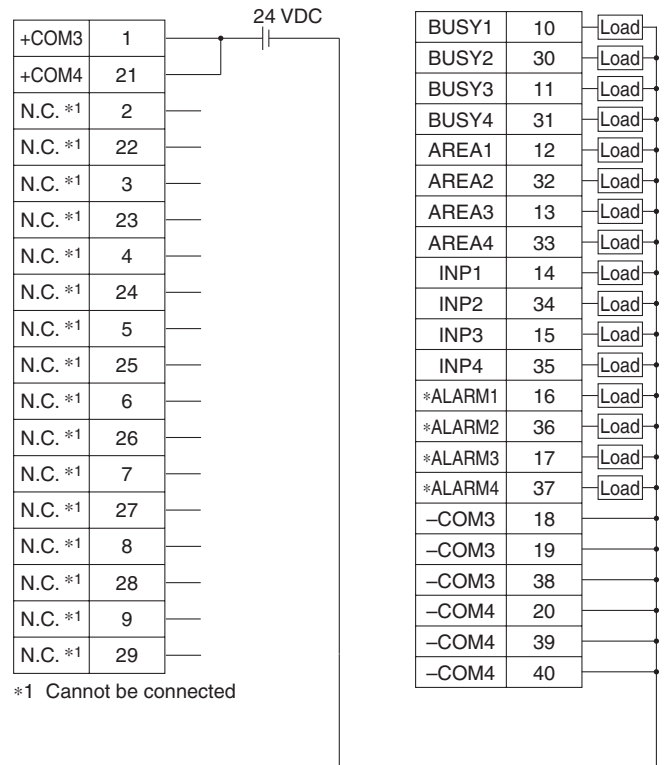

I/O 2 Input Signal

Name	Details
+COM3 +COM4	Connects the power supply 24 V for input/output signal
N.C.	Cannot be connected

I/O 2 Output Signal

Name	Details
BUSY1	Busy signal for axis 1
BUSY2	Busy signal for axis 2
BUSY3	Busy signal for axis 3
BUSY4	Busy signal for axis 4
AREA1	Area signal for axis 1
AREA2	Area signal for axis 2
AREA3	Area signal for axis 3
AREA4	Area signal for axis 4
INP1	Positioning or pushing completion signal for axis 1
INP2	Positioning or pushing completion signal for axis 2
INP3	Positioning or pushing completion signal for axis 3
INP4	Positioning or pushing completion signal for axis 4
*ALARM1 *2	Alarm signal for axis 1
*ALARM2 *2	Alarm signal for axis 2
*ALARM3 *2	Alarm signal for axis 3
*ALARM4 *2	Alarm signal for axis 4
-COM3 -COM4	Connects the power supply 0 V for input/output signal

*2 Negative-logic circuit signal

Model Selection

Servo Motor (24 VDC) (Step Motor (Servo 24 VDC))
LEY

LEYG

LECA6
LECP6

LEC-G

LECP1

LECPA

JXC□1

JXC73/83/92/93

AC Servo Motor
LEY

LEYG

LECS□

LECS-T

LECY□

Specific Product
Precautions

Series JXC73/83/92/93

Options

Cable with main control power supply connector

For 4 Axes
JXC73/83/93

JXC - C1

Cable length: 1.5 m (Accessory)

Number of cores	2
AWG size	AWG20

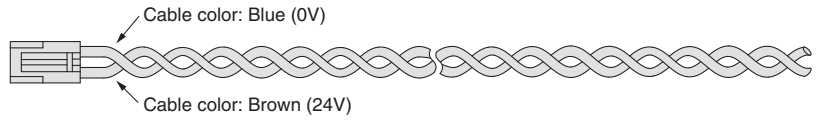

I/O cable (1 pc.)

JXC - C2 -

For 4 Axes
JXC73/83

Cable length (L) [m]

1	1.5
3	3
5	5

Number of cores	40
AWG size	AWG28

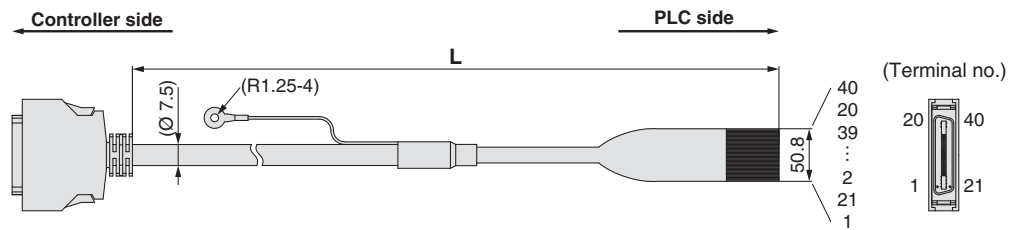

Pin no.	Wire colour	Pin no.	Wire colour	Pin no.	Wire colour	Pin no.	Wire colour
1	Orange (Black 1)	6	Orange (Black 2)	11	Orange (Black 3)	16	Orange (Black 4)
21	Orange (Red 1)	26	Orange (Red 2)	31	Orange (Red 3)	36	Orange (Red 4)
2	Grey (Black 1)	7	Grey (Black 2)	12	Grey (Black 3)	17	Grey (Black 4)
22	Grey (Red 1)	27	Grey (Red 2)	32	Grey (Red 3)	37	Grey (Red 4)
3	White (Black 1)	8	White (Black 2)	13	White (Black 3)	18	White (Black 4)
23	White (Red 1)	28	White (Red 2)	33	White (Red 3)	38	White (Red 4)
4	Yellow (Black 1)	9	Yellow (Black 2)	14	Yellow (Black 3)	19	Yellow (Black 4)
24	Yellow (Red 1)	29	Yellow (Red 2)	34	Yellow (Red 3)	39	Yellow (Red 4)
5	Pink (Black 1)	10	Pink (Black 2)	15	Pink (Black 3)	20	Pink (Black 4)
25	Pink (Red 1)	30	Pink (Red 2)	35	Pink (Red 3)	40	Pink (Red 4)

DIN rail

AXT100 - DR -

For 3 Axes
JXC92

For 4 Axes
JXC73/83/93

* For , enter a number from the No. line in the table below. Refer to the dimension drawings on pages 115 and 118 for the mounting dimensions.

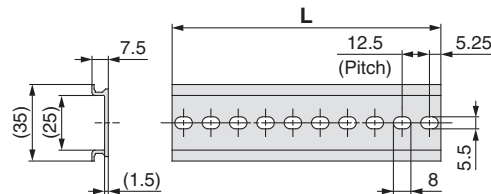

L Dimension

No.	1	2	3	4	5	6	7	8	9	10	11	12	13	14	15	16	17	18	19	20
L	23	35.5	48	60.5	73	85.5	98	110.5	123	135.5	148	160.5	173	185.5	198	210.5	223	235.5	248	260.5
No.	21	22	23	24	25	26	27	28	29	30	31	32	33	34	35	36	37	38	39	40
L	273	285.5	298	310.5	323	335.5	348	360.5	373	385.5	398	410.5	423	435.5	448	460.5	473	485.5	498	510.5

DIN rail mounting bracket (with 6 mounting screws)

For 3 Axes
JXC92

For 4 Axes
JXC73/83/93

JXC - Z1

This should be used when the DIN rail mounting bracket is mounted onto a screw mounting type controller afterwards.

Options

Controller setting kit

JXC-W1

For 4 Axes
JXC73/83/93

• Controller setting kit
(Japanese and English are available.)

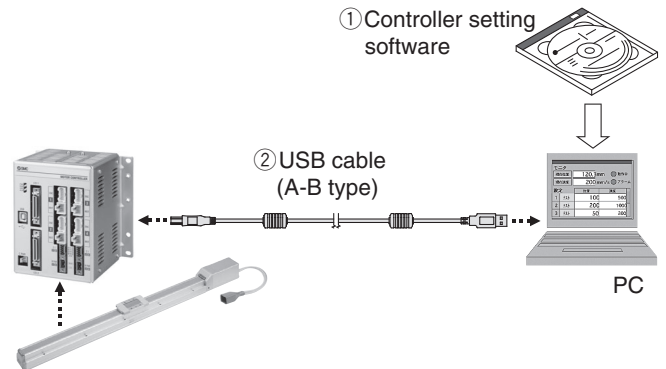

Contents

- ① Controller setting software (CD-ROM)
- ② USB cable (Cable length: 3 m)

Description	Model
① Controller setting software	JXC-W1-1
② USB cable	JXC-W1-2

* Can be ordered separately

Hardware Requirements

PC/AT compatible machine with Windows 7 or Windows 8.1 and USB1.1 or USB2.0 port

* Windows® is a registered trademark of Microsoft Corporation in the United States.

Controller setting kit

JXC-MA1*1

For 3 Axes
JXC92

• Controller setting kit
(Japanese and English are available.)

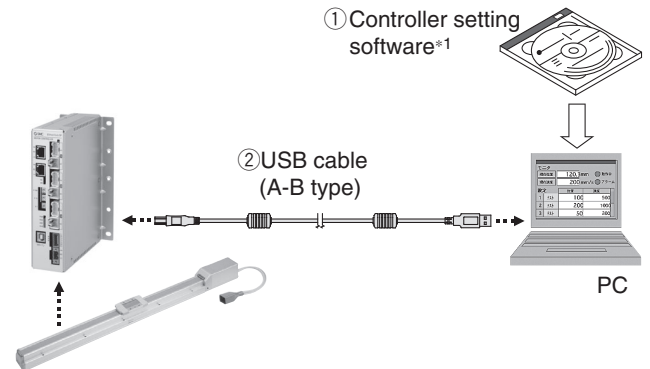

Contents

- ① Controller setting software (CD-ROM)*1
- ② USB cable (Cable length: 3 m)

Description	Model
① Controller setting software	JXC-MA1-1
② USB cable	JXC-MA1-2

* Can be ordered separately

Hardware Requirements

PC/AT compatible machine with Windows 7 or Windows 8.1 and USB1.1 or USB2.0 port

*1 The controller setting software also includes software dedicated for 4 axes.

* Windows® is a registered trademark of Microsoft Corporation in the United States.

Model Selection

LEY

LEYG

LECA6
LECP6

LEC-G

LECP1

LECPA

JXC□1

JXC73/83/92/93

LEY

LEYG

LECS□

LECS-T

LECY□

Specific Product Precautions

Series JXC73/83/92/93

Options: Actuator Cable

[Robotic cable, standard cable for step motor (Servo/24 VDC)]

For 3 Axes	For 4 Axes
JXC92	JXC73/83/93

LE-CP-1-

Cable length (L) [m]

1	1.5
3	3
5	5
8	8*1
A	10*1
B	15*1
C	20*1

*1 Produced upon receipt of order (Robotic cable only)

Cable type

—	Robotic cable (Flexible cable)
S	Standard cable

LE-CP-¹/₅/Cable length: 1.5 m, 3 m, 5 m

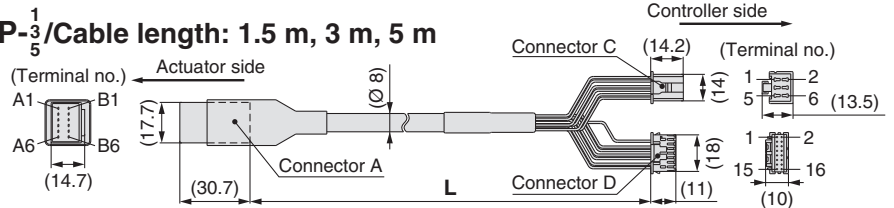

LE-CP-^{8B}/_{AC}/Cable length: 8 m, 10 m, 15 m, 20 m

(*1 Produced upon receipt of order)

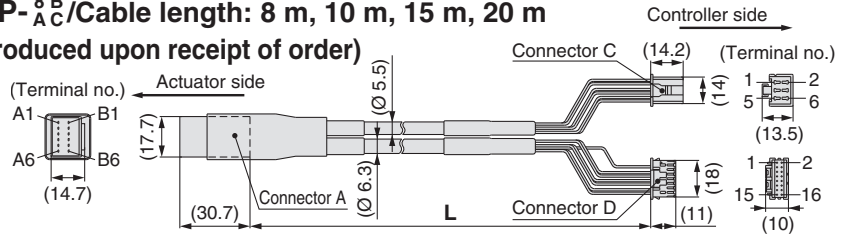

Signal	Connector A terminal no.	Cable colour	Connector C terminal no.
A	B-1	Brown	2
A	A-1	Red	1
B	B-2	Orange	6
B	A-2	Yellow	5
COM-A/COM	B-3	Green	3
COM-B/—	A-3	Blue	4
Signal	Connector A terminal no.	Cable colour	Connector D terminal no.
Vcc	B-4	Brown	12
GND	A-4	Black	13
A	B-5	Red	7
A	A-5	Black	6
B	B-6	Orange	9
B	A-6	Black	8
		—	3

[Robotic cable, standard cable with lock and sensor for step motor (Servo/24 VDC)]

For 3 Axes	For 4 Axes
JXC92	JXC73/83/93

LE-CP-1-B-

Cable length (L) [m]

1	1.5
3	3
5	5
8	8*1
A	10*1
B	15*1
C	20*1

*1 Produced upon receipt of order (Robotic cable only)

With lock and sensor

Cable type

—	Robotic cable (Flexible cable)
S	Standard cable

LE-CP-¹/₅/Cable length: 1.5 m, 3 m, 5 m

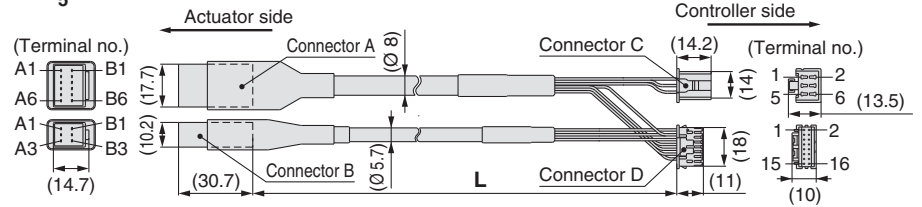

LE-CP-^{8B}/_{AC}/Cable length: 8 m, 10 m, 15 m, 20 m

(*1 Produced upon receipt of order)

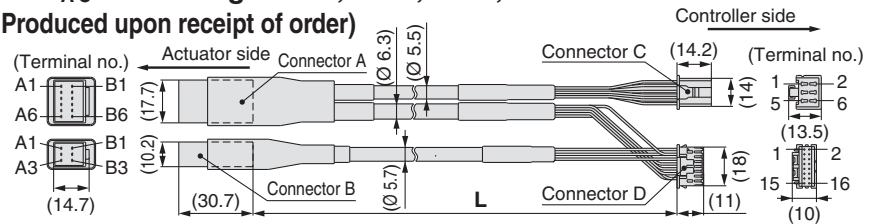

Signal	Connector A terminal no.	Cable colour	Connector C terminal no.
A	B-1	Brown	2
A	A-1	Red	1
B	B-2	Orange	6
B	A-2	Yellow	5
COM-A/COM	B-3	Green	3
COM-B/—	A-3	Blue	4
Signal	Connector A terminal no.	Cable colour	Connector D terminal no.
Vcc	B-4	Brown	12
GND	A-4	Black	13
A	B-5	Red	7
A	A-5	Black	6
B	B-6	Orange	9
B	A-6	Black	8
		—	3
Signal	Connector B terminal no.	Cable colour	Connector D terminal no.
Lock (+)	B-1	Red	4
Lock (-)	A-1	Black	5
Sensor (+)	B-3	Brown	1
Sensor (-)	A-3	Blue	2

AC Servo Motor

Rod Type **Page 127**

Series **LEY**

Motor top/parallel type

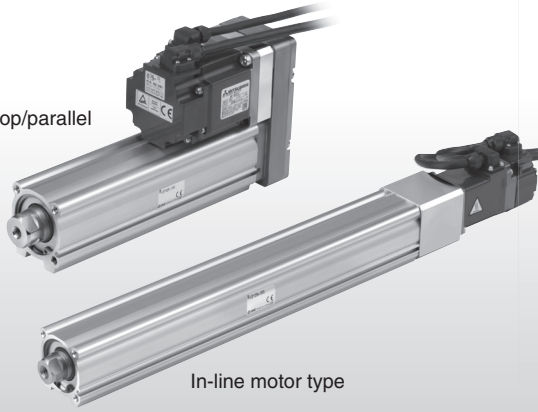

In-line motor type

Dust/Drip proof (IP65 equivalent)

Page 150

Series **LEY-X5**

Motor top mounting type

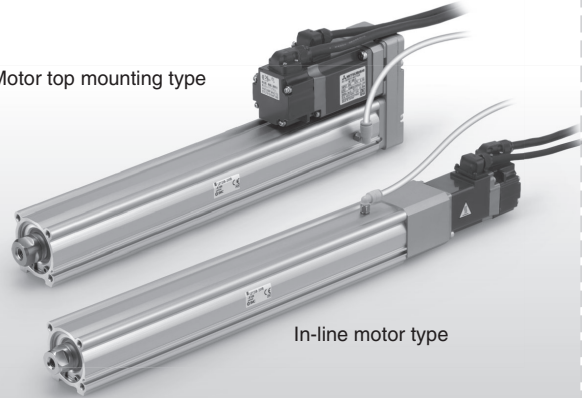

In-line motor type

Rod Type **Page 155**

Secondary Batteries Compatible

Series **25A-LEY**

Motor top mounting type

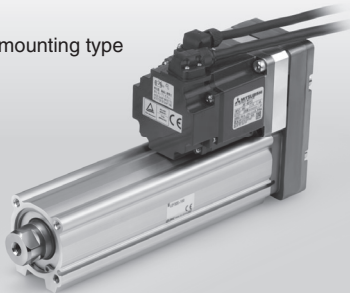

Guide Rod Type **Page 157**

Series **LEYG**

Motor top mounting type

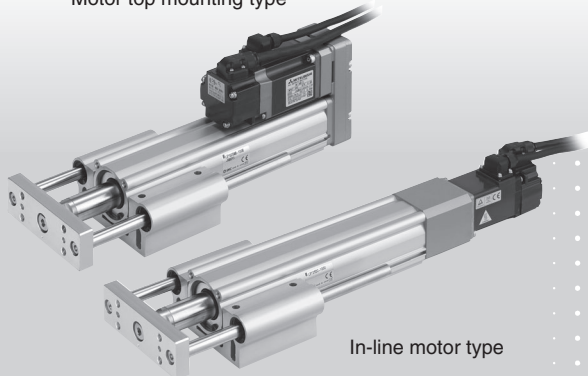

In-line motor type

AC Servo Motor Driver

Series **LECS** □

Page 173

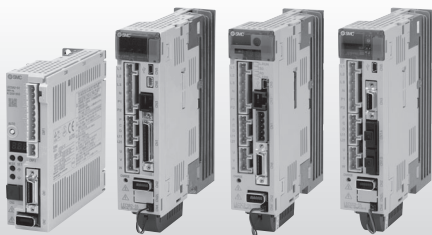

Series **LECSS-T**

Page 189



Series **LECY** □

Page 200



Model Selection

Servo Motor (24 VDC) / Step Motor (Servo/24 VDC)

LEY

LEYG

LEC-G

LECA6
LECP6

LECP1

LECPA

JXC □ 1

JXC7303/92/93

AC Servo Motor

LEY

LEYG

LECS □

LECSS-T

LECY □

Specific Product Precautions

Model Selection

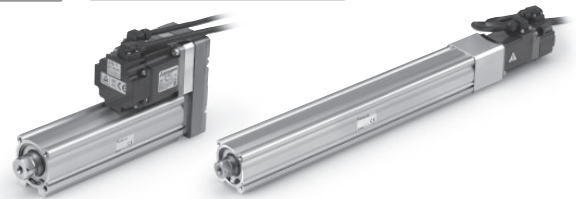

Selection Procedure

Positioning Control Selection Procedure



Selection Example

Operating conditions

- Workpiece mass: 16 [kg]
- Speed: 300 [mm/s]
- Acceleration/Deceleration: 5,000 [mm/s²]
- Stroke: 300 [mm]
- Workpiece mounting condition: Vertical upward downward transfer

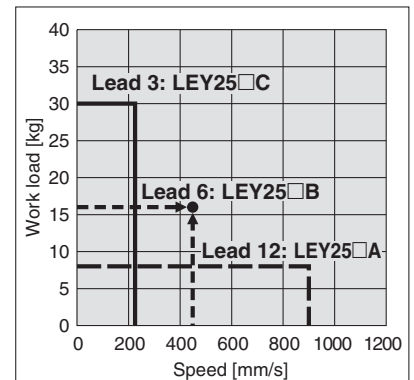

<Speed-Vertical work load graph> (LEY25)

Step 1 Check the work load-speed. <Speed-Vertical work load graph>

Select the target model based on the workpiece mass and speed with reference to the <Speed-Vertical work load graph>.

Selection example) The **LEY25 B** is temporarily selected based on the graph shown on the right side.

* It is necessary to mount a guide outside the actuator when used for horizontal transfer. When selecting the target model, refer to pages 135, 144 and 151 for the horizontal work load in the specifications, and page 169 for the precautions.

The regeneration option may be necessary. Refer to pages 129, 130 and 131 for "Required Conditions for Regeneration Option".

Step 2 Check the cycle time.

Calculate the cycle time using the following calculation method.

- Cycle time T can be found from the following equation.

$$T = T1 + T2 + T3 + T4 \text{ [s]}$$

- T1: Acceleration time and T3: Deceleration time can be obtained by the following equation.

$$T1 = V/a1 \text{ [s]} \quad T3 = V/a2 \text{ [s]}$$

- T2: Constant speed time can be found from the following equation.

$$T2 = \frac{L - 0.5 \cdot V \cdot (T1 + T3)}{V} \text{ [s]}$$

- T4: Settling time varies depending on the conditions such as motor types, load and in positioning of the step data. Therefore, please calculate the settling time with reference to the following value.

$$T4 = 0.05 \text{ [s]}$$

Calculation example)

T1 to T4 can be calculated as follows.

$$T1 = V/a1 = 300/5000 = 0.06 \text{ [s]}, \quad T3 = V/a2 = 300/5000 = 0.06 \text{ [s]}$$

$$T2 = \frac{L - 0.5 \cdot V \cdot (T1 + T3)}{V} = \frac{300 - 0.5 \cdot 300 \cdot (0.06 + 0.06)}{300} = 0.94 \text{ [s]}$$

$$T4 = 0.05 \text{ [s]}$$

Therefore, the cycle time can be obtained as follows.

$$T = T1 + T2 + T3 + T4 = 0.06 + 0.94 + 0.06 + 0.05 = 1.11 \text{ [s]}$$

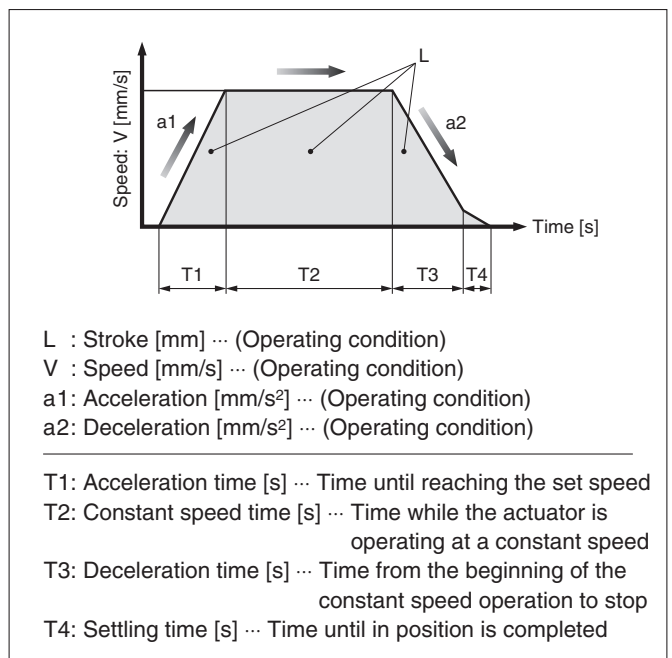

Based on the above calculation result, the **LEY25 B-300** is selected.

Selection Procedure

Force Control Selection Procedure



* The duty ratio is a ratio of the operation time in one cycle.

Selection Example

Operating conditions

- Mounting condition: Horizontal (pushing)
- Jig weight: 0.5 [kg]
- Force: 255 [N]
- Duty ratio: 60 [%]
- Speed: 100 [mm/s]
- Stroke: 300 [mm]

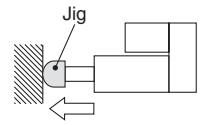

Step 1 Check the duty ratio.

<Conversion table of force–duty ratio>

Select the [Force] from the duty ratio with reference to the <Conversion table of force–duty ratio>.

Selection example)

Based on the table below,

- Duty ratio: 60 [%]

Therefore, Torque limit/Command value will be 30 [%].

<Conversion table of force–duty ratio>

(LEY25/AC Servo motor)

Torque limit/Command value [%]	Duty ratio [%]	Continuous pushing time [minute]
25 or less	100	—
30	60	1.5

* [Torque limit/Command value [%]] is the set value for the driver.

* [Continuous pushing time] is the time that the actuator can continuously keep pushing.

Step 2 Check the force. <Force conversion graph>

Select the target model based on the torque limit/command value and pushing force with reference to the <Force conversion graph>.

Selection example)

Based on the graph shown on the right side,

- Torque limit/Command value: 30 [%]
- Force: 255 [N]

Therefore, the **LEY25B** is temporarily selected.

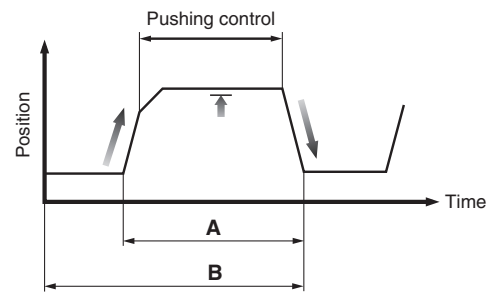

$$\text{Duty ratio} = A/B \times 100 [\%]$$

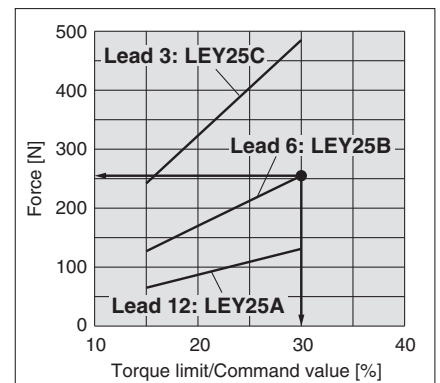

<Force conversion graph> (LEY25)

Step 3 Check the lateral load on the rod end.

<Graph of allowable lateral load on the rod end>

Confirm the allowable lateral load on the rod end of the actuator: LEY25B, which has been selected temporarily with reference to the <Graph of allowable lateral load on the rod end>.

Selection example)

Based on the graph shown on the right side,

- Jig weight: 0.5 [kg] \approx 5 [N]
- Product stroke: 300 [mm]

Therefore, the lateral load on the rod end is in the allowable range.

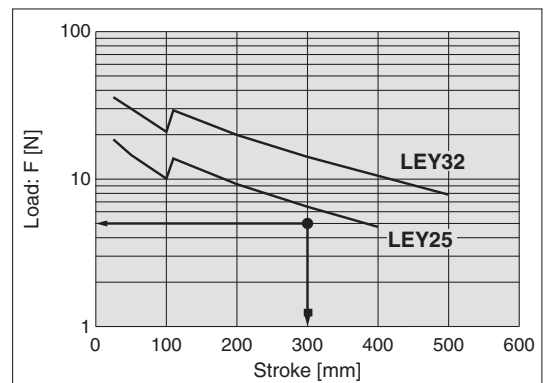

<Graph of allowable lateral load on the rod end>

Based on the above calculation result, the **LEY25B-300** is selected.

Series LEY/LEY-X5

AC Servo Motor

Size 25, 32, 63

Dust/Drip proof (IP65 equivalent)

Speed-Vertical Work Load Graph/Required Conditions for "Regeneration Option"

LEY25□ (Motor mounting position: Top/Parallel, In-line)

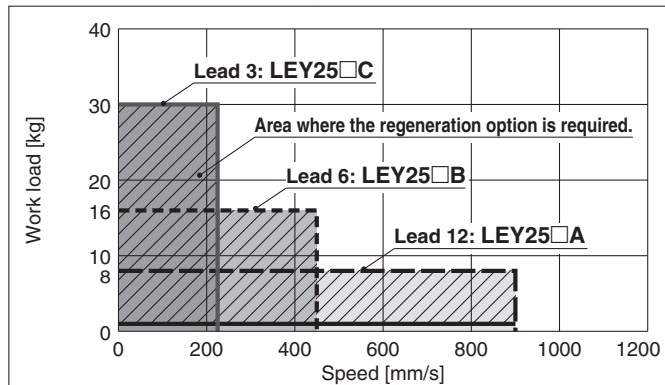

Required conditions for "Regeneration option"

* Regeneration option is required when using product above regeneration line in graph. (Order separately.)

"Regeneration Option" Models

Size	Model
LEY25□	LEC-MR-RB-032
LEY32□	LEC-MR-RB-032
LEY63□	LEC-MR-RB-12

LEY32□ (Motor mounting position: Top/Parallel)

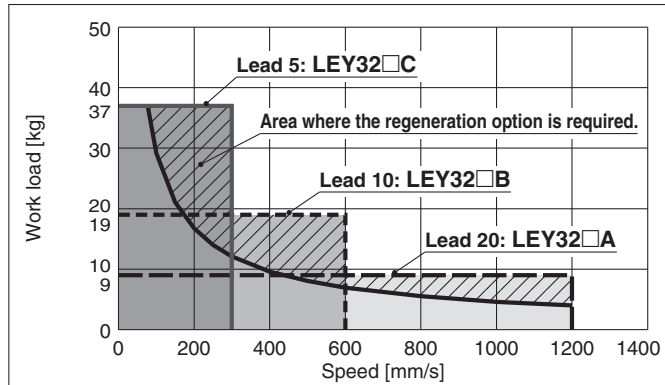

LEY32D (Motor mounting position: In-line)

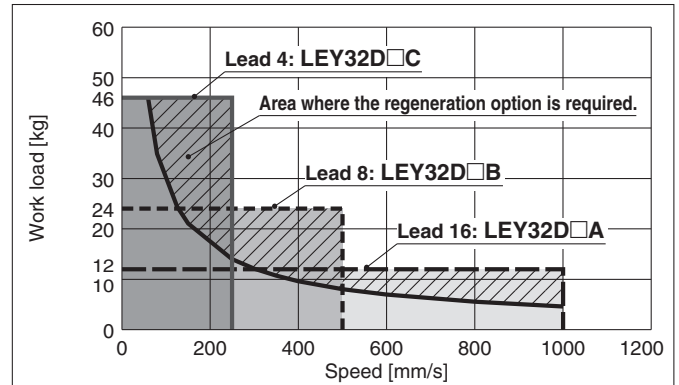

LEY63□ (Motor mounting position: Top/Parallel, In-line)

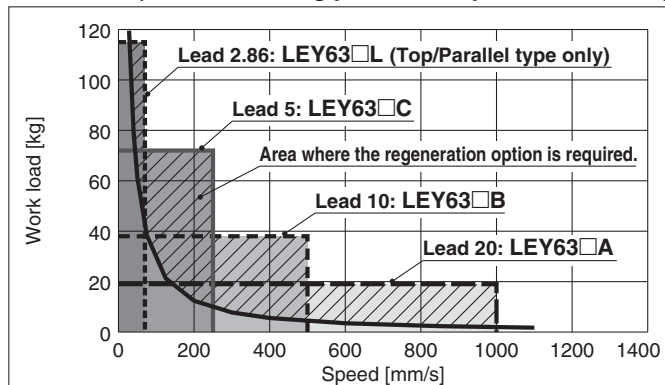

Speed–Horizontal Work Load Graph/Required Conditions for “Regeneration Option”

LEY25□ (Motor mounting position: Top/Parallel, In-line)

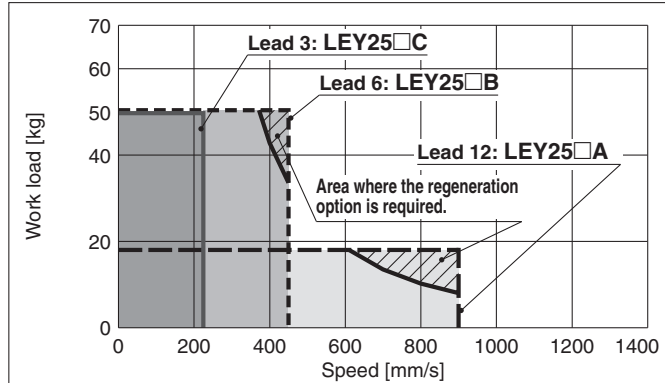

Required conditions for “Regeneration option”

* Regeneration option is required when using product above regeneration line in graph. (Order separately.)

“Regeneration Option” Models

Size	Model
LEY25□	LEC-MR-RB-032
LEY32□	LEC-MR-RB-032
LEY63□	—

LEY32□ (Motor mounting position: Top/Parallel)

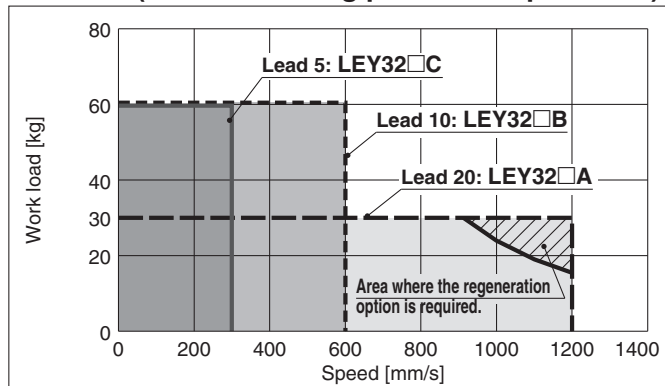

LEY32D (Motor mounting position: In-line)

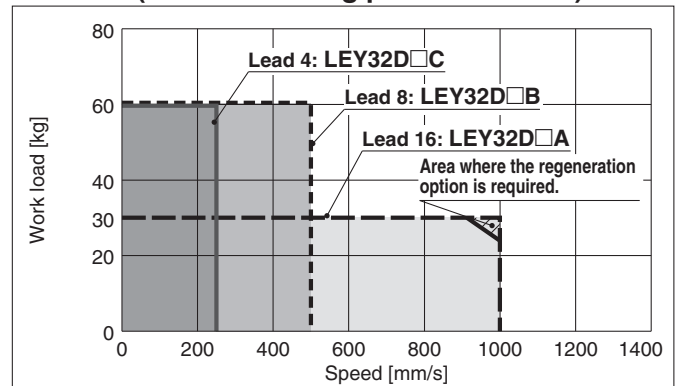

LEY63□ (Motor mounting position: Top/Parallel, In-line)

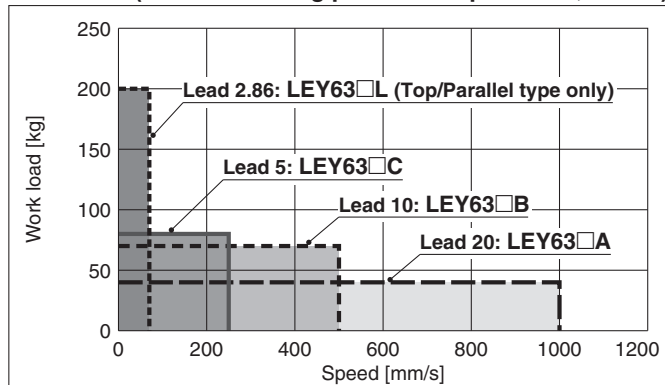

Allowable Stroke Speed

Model	AC servo motor	Lead	Stroke [mm]															
			Symbol	[mm]	30	50	100	150	200	250	300	350	400	450	500	600	700	800
LEY25□ (Motor mounting position: Top/Parallel, In-line)	100 W □40	A	12				900					600						
		B	6				450					300						
		C	3				225					150						
		(Motor rotation speed)					(4500 rpm)					(3000 rpm)						
LEY32□ (Motor mounting position: Top/Parallel)	200 W □60	A	20					1200						800				
		B	10					600						400				
		C	5					300						200				
		(Motor rotation speed)						(3600 rpm)						(2400 rpm)				
LEY32D (Motor mounting position: In-line)	200 W □60	A	16					1000						640				
		B	8					500						320				
		C	4					250						160				
		(Motor rotation speed)						(3750 rpm)						(2400 rpm)				
LEY63□ (Motor mounting position: Top/Parallel, In-line)	400 W □60	A	20						1000						800	600	500	
		B	10						500						400	300	250	
		C	5						250						200	150	125	
		(Motor rotation speed)							(3000 rpm)						(2400 rpm)	(1800 rpm)	(1500 rpm)	
		L*	2.86								70							
(Motor rotation speed)									(1470 rpm)									

* Top/Parallel type only

Series LEY/LEY-X5

AC Servo Motor

Size 25, 32, 63

Dust/Drip proof (IP65 equivalent)

Force Conversion Graph (Guide)

LEY25 (Motor mounting position: Top/Parallel, In-line)

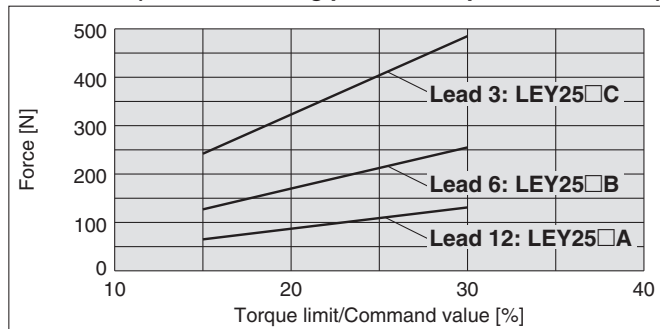

Torque limit/Command value [%]	Duty ratio [%]	Continuous pushing time [minute]
25 or less	100	—
30	60	1.5

LEY32 (Motor mounting position: Top/Parallel)

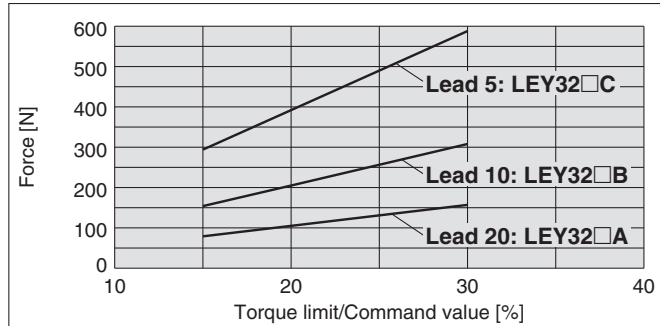

Torque limit/Command value [%]	Duty ratio [%]	Continuous pushing time [minute]
25 or less	100	—
30	60	1.5

LEY32D (Motor mounting position: In-line)

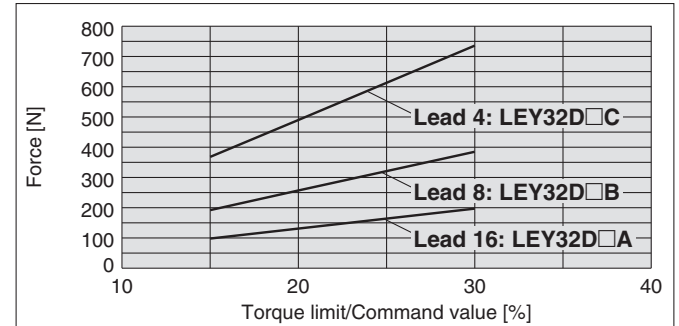

Torque limit/Command value [%]	Duty ratio [%]	Continuous pushing time [minute]
25 or less	100	—
30	60	1.5

LEY63 (Motor mounting position: Top/Parallel, In-line)

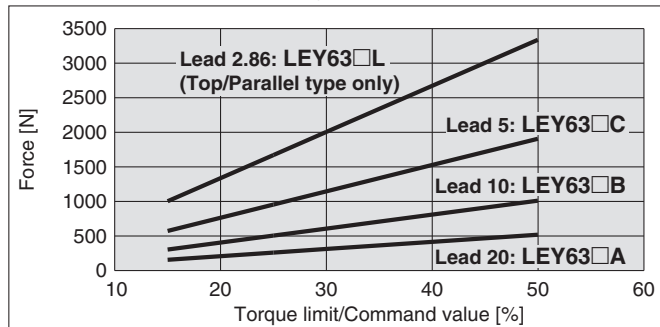

Torque limit/Command value [%]	Duty ratio [%]	Continuous pushing time [minute]
25 or less	100	—
30	60	1.5
40	30	0.5
50	20	0.16

Graph of Allowable Lateral Load on the Rod End (Guide)

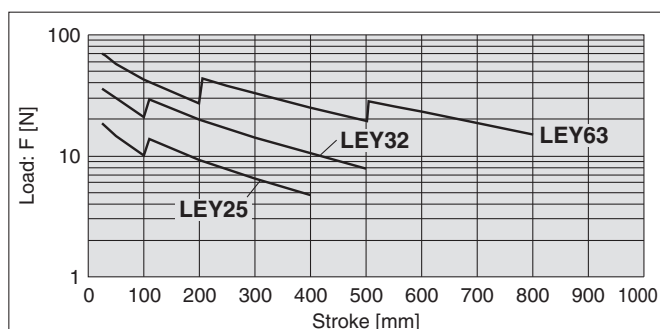

[Stroke] = [Product stroke] + [Distance from the rod end to the center of gravity of the workpiece]

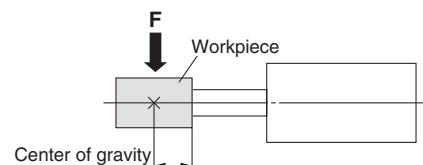

Servo Motor (24 VDC)/Step Motor (Servo/24 VDC)

LEYG LEY

LECA6
LECP6

LEC-G

LECP1

LECPA

JXC□1

JXC7/3/63/92/99

AC Servo Motor

LEYG

LEY

LECS□

LECSS-T

LECY□

Specific Product Precautions

Electric Actuator/ Rod Type

Series **LEY** LEY25, 32, 63 Size 25, 32, 63



Please contact SMC for dust-tight/water-jet-proof (IP65 equivalent) and the models compatible with secondary batteries.

Compatible ▶Page 200

How to Order

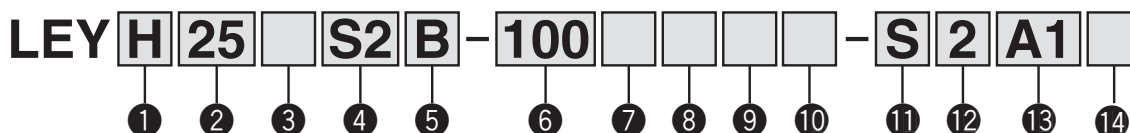

1 Accuracy

—	Basic type
H	High precision type

2 Size

25
32
63

3 Motor mounting position

—	Top mounting
R	Right side parallel
L	Left side parallel
D	In-line

5 Lead [mm]

Symbol	LEY25	LEY32 *1	LEY63
A	12	16 (20)	20
B	6	8 (10)	10
C	3	4 (5)	5
L	—	—	2.86 *2

*1 The values shown in () are the lead for top mounting, right/left side parallel types. (Equivalent lead which includes the pulley ratio [1.25:1])

*2 Only available for top mounting and right/left side parallel types. (Equivalent lead which includes the pulley ratio [4:7])

6 Stroke [mm]

30	30
to	to
800	800

* Refer to the applicable stroke table for details.

9 Rod end thread

—	Rod end female thread
M	Rod end male thread (1 rod end nut is included.)

4 Motor type*1, 2

Symbol	Type	Output [W]	Actuator size	Compatible drivers*2
S2	AC servo motor (Incremental encoder)	100	25	LECSA□-S1
S3	AC servo motor (Incremental encoder)	200	32	LECSA□-S3
S6	AC servo motor (Absolute encoder)	100	25	LECSB□-S5 LECS□-S5 LECSS□-S5
S7	AC servo motor (Absolute encoder)	200	32	LECSB□-S7 LECS□-S7 LECSS□-S7
T6	AC servo motor (Absolute encoder)	100	25	LECSS2-T5
T7		200	32	LECSS2-T7

*1 For motor type S2 and S6, the compatible driver part number suffixes are S1 and S5 respectively.

*2 For motor type T6, the compatible driver part number suffix is T5.

*3 For details about the driver, refer to page 173.

7 Dust-tight/Water-jet-proof (Only available for LEY63)

Symbol	LEY25/32	LEY63
—	IP4x equivalent	IP5x equivalent (Dust-protected)
P	—	IP65 equivalent (Dust-tight/Water-jet-proof)/With vent hole tap

* When using the dust-tight/water-jet-proof (IP65 equivalent), correctly mount the fitting and tubing to the vent hole tap, and then place the end of the tubing in an area not exposed to dust or water.

* The fitting and tubing should be provided separately by the customer. Select [Applicable tubing O.D.: ø4 or more, Connection thread: Rc1/8].

* Cannot be used in environments exposed to cutting oil etc. Take suitable protective measures. For details about enclosure, refer to "Enclosure" on page 306.

8 Motor option

—	Without option
B	With lock*

* When "With lock" is selected for the top mounting and right/left side parallel types, the motor body will stick out of the end of the body for size 25 with strokes 30 mm or less. Check for interference with workpieces before selecting a model.

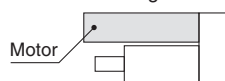

10 Mounting*1

Symbol	Type	Motor mounting position	
		Top/Parallel	In-line
—	Ends tapped/ Body bottom tapped *2	●	●
L	Foot	●	—
F	Rod flange*2	●*4	●
G	Head flange*2	●*5	—
D	Double clevis*3	●	—

*1 Mounting bracket is shipped together, (but not assembled).

*2 For horizontal cantilever mounting with the rod flange, head flange and ends tapped, use the actuator within the following stroke range.
• LEY25: 200 mm or less • LEY32: 100 mm or less

*3 For mounting with the double clevis, use the actuator within the following stroke range.
• LEY25: 200 mm or less • LEY32: 200 mm or less

*4 Rod flange is not available for the LEY25 with stroke 30 mm and motor option "With lock".

*5 Head flange is not available for the LEY32.

Applicable Stroke Table

Model	Stroke [mm]														Manufacturable stroke range	
		30	50	100	150	200	250	300	350	400	450	500	600	700		800
LEY25		●	●	●	●	●	●	●	●	●	—	—	—	—	—	15 to 400
LEY32		●	●	●	●	●	●	●	●	●	●	—	—	—	—	20 to 500
LEY63		—	●	●	●	●	●	●	●	●	●	●	●	●	●	50 to 800

* Please consult with SMC for non-standard strokes as they are produced as special orders.

For auto switches, refer to pages 27 and 28.

Electric Actuator/Rod Type **Series LEY**

AC Servo Motor

Size **25, 32**

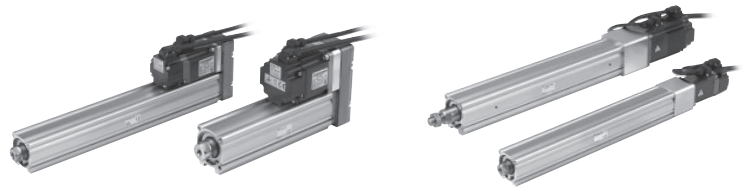

Motor mounting position: Top/Parallel Motor mounting position: In-line

11 Cable type*

—	Without cable
S	Standard cable
R	Robotic cable (Flexible cable)

* The motor and encoder cables are included. (The lock cable is also included when the motor with lock option is selected.)

* Standard cable entry direction is
 • Top/Parallel: (A) Axis side
 • In-line: (B) Counter axis side
 (Refer to page 185 for details.)

12 Cable length* [m]

—	Without cable
2	2
5	5
A	10

* The length of the encoder, motor and lock cables are the same.

13 Driver type*

	Compatible driver	Power supply voltage [V]
—	Without driver	—
A1	LECSA1-S□	100 to 120
A2	LECSA2-S□	200 to 230
B1	LECSB1-S□	100 to 120
B2	LECSB2-S□	200 to 230
C1	LECS1-S□	100 to 120
C2	LECS2-S□	200 to 230
S1	LECSS1-S□	100 to 120
S2	LECSS2-S□	200 to 230
	LECSS2-T□	200 to 240

* When the driver type is selected, the cable is included. Select cable type and cable length.
 Example)
 S2S2: Standard cable (2 m) + Driver (LECSS2)
 S2: Standard cable (2 m)
 —: Without cable and driver

14 I/O cable length [m]*

—	Without cable
H	Without cable (Connector only)
1	1.5

* When "Without driver" is selected for driver type, only "—: Without cable" can be selected. Refer to page 186 if I/O cable is required. (Options are shown on page 186.)

Compatible Driver

Driver type	Pulse input type /Positioning type	Pulse input type	CC-Link direct input type	SSCNET III type	SSCNET III/H Type
Series	LECSA	LECSB	LECS1	LECS2	LECSS-T
Number of point tables	Up to 7	—	Up to 255 (2 stations occupied)	—	—
Pulse input	○	○	—	—	—
Applicable network	—	—	CC-Link	SSCNET III	SSCNET III/H
Control encoder	Incremental 17-bit encoder	Absolute 18-bit encoder	Absolute 18-bit encoder	Absolute 18-bit encoder	Absolute 22-bit encoder
Communication function	USB communication	USB communication, RS422 communication	USB communication, RS422 communication	USB communication	USB communication
Power supply voltage [V]	100 to 120 VAC (50/60 Hz) 200 to 230 VAC (50/60 Hz)				200 to 240 VAC (50/60 Hz)
Reference page	Page 173				Page 189

Model Selection

LEY

LEYG

LECA6
LECP6

LEC-G

LECP1

LECPA

JXC□1

JXC7303/9293

LEY

LEYG

LECS□

LECS-T

LECY□

Specific Product Precautions

Series LEY

AC Servo Motor

Size **25, 32**

Specifications

Model		LEY25S $\frac{1}{2}$ (Top/Parallel)/LEY25DS $\frac{1}{2}$ (In-line)				LEY32S $\frac{3}{4}$ (Top/Parallel)				LEY32DS $\frac{3}{4}$ (In-line)							
Actuator specifications	Stroke [mm] ^{Note 1)}	30, 50, 100, 150, 200, 250, 300, 350, 400								30, 50, 100, 150, 200, 250, 300, 350, 400, 450, 500				30, 50, 100, 150, 200, 250, 300, 350, 400, 450, 500			
	Work load [kg]	Horizontal ^{Note 2)}	18	50	50	30	60	60	30	60	60	30	60	60			
		Vertical	8	16	30	9	19	37	12	24	46						
	Force [N] ^{Note 3)} (Set value: 15 to 30 %)	65 to 131	127 to 255	242 to 485	79 to 157	154 to 308	294 to 588	98 to 197	192 to 385	368 to 736							
	Max. ^{Note 4)} speed [mm/s]	Stroke range	Up to 300	900	450	225	1200	600	300	1000	500	250					
			305 to 400	600	300	150	800	400	200	640	320	160					
			405 to 500	—	—	—	—	—	—	—	—	—					
	Pushing speed [mm/s ²] ^{Note 5)}	35 or less				30 or less				30 or less							
	Max. acceleration/deceleration [mm/s ²]	5000								5000							
	Positioning repeatability [mm]	Basic type	±0.02								±0.01						
			High precision type	±0.01								±0.01					
	Lost motion [mm] ^{Note 6)}	Basic type		0.1 or less								0.1 or less					
			High precision type	0.05 or less								0.05 or less					
	Lead [mm] (including pulley ratio)	12		6	3	20	10	5	16	8	4						
	Impact/Vibration resistance [m/s ²] ^{Note 7)}	50/20								50/20							
Actuation type	Ball screw + Belt (LEY□□)/Ball screw (LEY□□)				Ball screw + Belt [1.25:1]				Ball screw								
Guide type	Sliding bushing (Piston rod)								Sliding bushing (Piston rod)								
Operating temperature range [°C]	5 to 40								5 to 40								
Operating humidity range [%RH]	90 or less (No condensation)								90 or less (No condensation)								
Regeneration option ^{Note 8)}	May be required depending on speed and work load (refer to pages 129 and 130)																
Motor output/Size	100 W/□40				200 W/□60												
Motor type	AC servo motor (100/200 VAC)				AC servo motor (100/200 VAC)												
Encoder	Motor type S2, S3: Incremental 17-bit encoder (Resolution: 131072 p/rev) Motor type S6, S7: Absolute 18-bit encoder (Resolution: 262144 p/rev)																
Power consumption [W] ^{Note 9)}	Horizontal	45	65	65	65	175	175	65	175	175							
	Vertical	145	175	175	175	175	175	175	175	175							
Standby power consumption when operating [W] ^{Note 10)}	Horizontal	2	2	2	2	2	2	2	2	2							
	Vertical	8	8	8	8	8	8	8	8	8							
Max. instantaneous power consumption [W] ^{Note 11)}	445	724	724	724	724	724	724	724	724								
Type ^{Note 12)}	Non-magnetizing lock																
Lock unit specifications	Holding force [N]	131	255	485	157	308	588	197	385	736							
	Power consumption [W] at 20 °C ^{Note 13)}	6.3				7.9				7.9							
	Rated voltage [V]	24 VDC $_{-10}^{0}$ %															

- Note 1) Please consult with SMC for non-standard strokes as they are produced as special orders.
 Note 2) The maximum value of the horizontal work load. An external guide is necessary to support the load. The actual work load changes according to the condition of the external guide. Please confirm using actual device.
 Note 3) The force setting range (set values for the driver) for the force control with the torque control mode. Set it with reference to "Force Conversion Graph" on page 131. When the control equivalent to the pushing operation of the controller LECF series is performed, select the LECSS driver and combine it with the Simple Motion (manufactured by Mitsubishi Electric Corporation) which has a pushing operation function.
 Note 4) The allowable speed changes according to the stroke. Set the number of rotations according to speed.
 Note 5) The allowable collision speed for collision with the workpiece with the torque control mode.
 Note 6) A reference value for correcting an error in reciprocal operation.
 Note 7) Impact resistance: No malfunction occurred when the actuator was tested with a drop tester in both an axial direction and a perpendicular direction to the lead screw. (Test was

- performed with the actuator in the initial state.)
 Vibration resistance: No malfunction occurred in a test ranging between 45 to 2000 Hz. Test was performed in both an axial direction and a perpendicular direction to the lead screw. (Test was performed with the actuator in the initial state.)
 Note 8) The work load conditions which require "Regeneration option" when operating at the maximum speed (Duty ratio: 100 %). Order the regeneration option separately. For details and order numbers, refer to "Required Conditions for Regeneration Option" on pages 129 and 130.
 Note 9) The power consumption (including the driver) is for when the actuator is operating.
 Note 10) The standby power consumption when operating (including the driver) is for when the actuator is stopped in the set position during the operation.
 Note 11) The maximum instantaneous power consumption (including the driver) is for when the actuator is operating.
 Note 12) Only when motor option "With lock" is selected.
 Note 13) For an actuator with lock, add the power consumption for the lock.

Weight

Product Weight

Series		LEY25S□ (Motor mounting position: Top/Parallel)								LEY32S□ (Motor mounting position: Top/Parallel)											
Stroke [mm]		30	50	100	150	200	250	300	350	400	30	50	100	150	200	250	300	350	400	450	500
Motor type	Incremental encoder	1.31	1.38	1.55	1.81	1.99	2.16	2.34	2.51	2.69	2.42	2.53	2.82	3.29	3.57	3.85	4.14	4.42	4.70	4.98	5.26
	Absolute encoder	1.37	1.44	1.61	1.87	2.05	2.22	2.40	2.57	2.75	2.36	2.47	2.76	3.23	3.51	3.79	4.08	4.36	4.64	4.92	5.20

Series		LEY25DS□ (Motor mounting position: In-line)								LEY32DS□ (Motor mounting position: In-line)											
Stroke [mm]		30	50	100	150	200	250	300	350	400	30	50	100	150	200	250	300	350	400	450	500
Motor type	Incremental encoder	1.34	1.41	1.58	1.84	2.02	2.19	2.37	2.54	2.72	2.44	2.55	2.84	3.31	3.59	3.87	4.16	4.44	4.72	5.00	5.28
	Absolute encoder	1.40	1.47	1.64	1.90	2.08	2.25	2.43	2.60	2.78	2.38	2.49	2.78	3.25	3.53	3.81	4.10	4.38	4.66	4.94	5.22

Additional Weight

Size		25	32
Lock	Incremental encoder	0.20	0.40
	Absolute encoder	0.30	0.66
Rod end male thread	Male thread	0.03	0.03
	Nut	0.02	0.02
Foot (2 sets including mounting bolt)		0.08	0.14
Rod flange (including mounting bolt)		0.17	0.20
Head flange (including mounting bolt)			
Double clevis (including pin, retaining ring and mounting bolt)		0.16	0.22

Construction

Motor top mounting type: LEY²⁵/₃₂

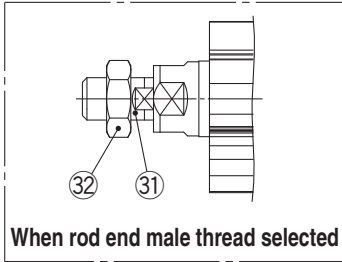
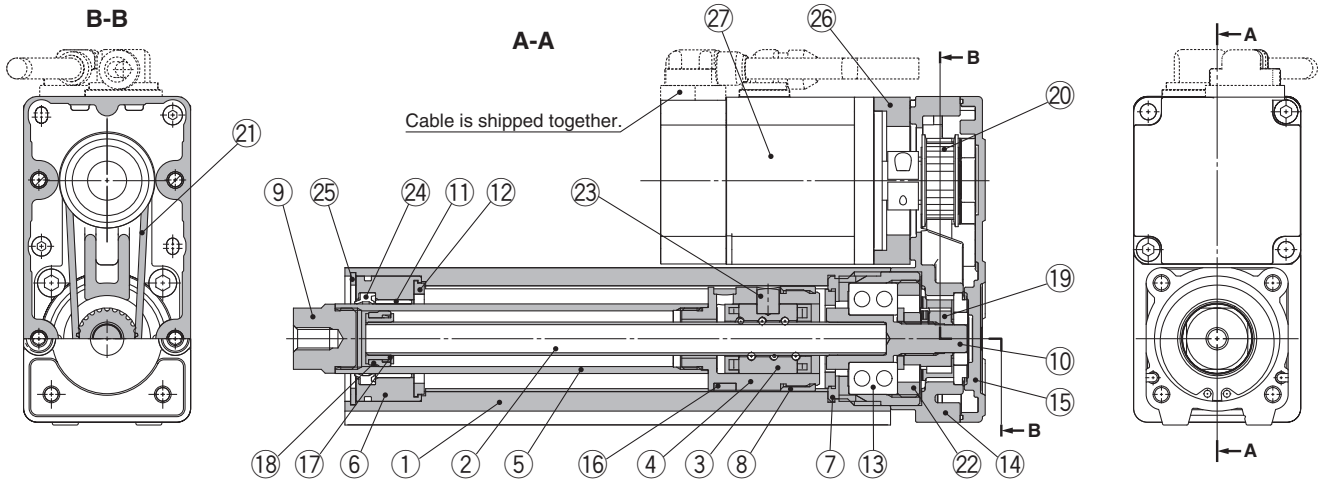

In-line motor type: LEY²⁵/₃₂D

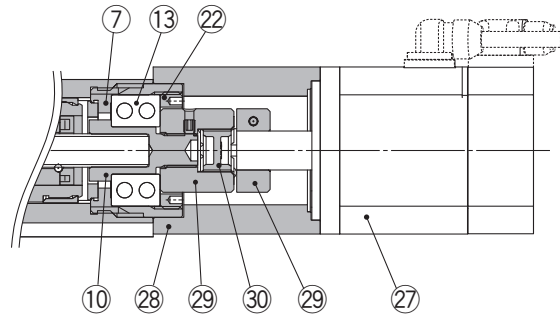

Component Parts

No.	Description	Material	Note
1	Body	Aluminium alloy	Anodised
2	Ball screw (shaft)	Alloy steel	
3	Ball screw nut	Resin/Alloy steel	
4	Piston	Aluminium alloy	
5	Piston rod	Stainless steel	Hard chrome Anodised
6	Rod cover	Aluminium alloy	
7	Housing	Aluminium alloy	
8	Rotation stopper	POM	
9	Socket	Free cutting carbon steel	Nickel plated
10	Connected shaft	Free cutting carbon steel	Nickel plated
11	Bushing	Lead bronze cast	
12	Bumper	Urethane	
13	Bearing	—	
14	Return box	Aluminium die-cast	Coating
15	Return plate	Aluminium die-cast	Coating
16	Magnet	—	
17	Wear ring holder	Stainless steel	Stroke 101 mm or more
18	Wear ring	POM	Stroke 101 mm or more
19	Screw shaft pulley	Aluminium alloy	
20	Motor pulley	Aluminium alloy	
21	Belt	—	
22	Bearing stopper	Aluminium alloy	
23	Parallel pin	Stainless steel	

No.	Description	Material	Note
24	Seal	NBR	
25	Retaining ring	Steel for spring	Phosphate coated
26	Motor adapter	Aluminium alloy	Coating
27	Motor	—	
28	Motor block	Aluminium alloy	Coating
29	Hub	Aluminium alloy	
30	Spider	Urethane	
31	Socket (Male thread)	Free cutting carbon steel	Nickel plated
32	Nut	Alloy steel	Zinc chromated

Replacement Parts (Top/Parallel only)/Belt

No.	Size	Order no.
21	25	LE-D-2-2
	32	LE-D-2-4

Replacement Parts/Grease Pack

Applied portion	Order no.
Piston rod	GR-S-010 (10 g) GR-S-020 (20 g)

* Apply grease on the piston rod periodically.
Grease should be applied at 1 million cycles or 200 km, whichever comes first.

Series LEY

AC Servo Motor

Size 25, 32

Dimensions: Motor Top/Parallel

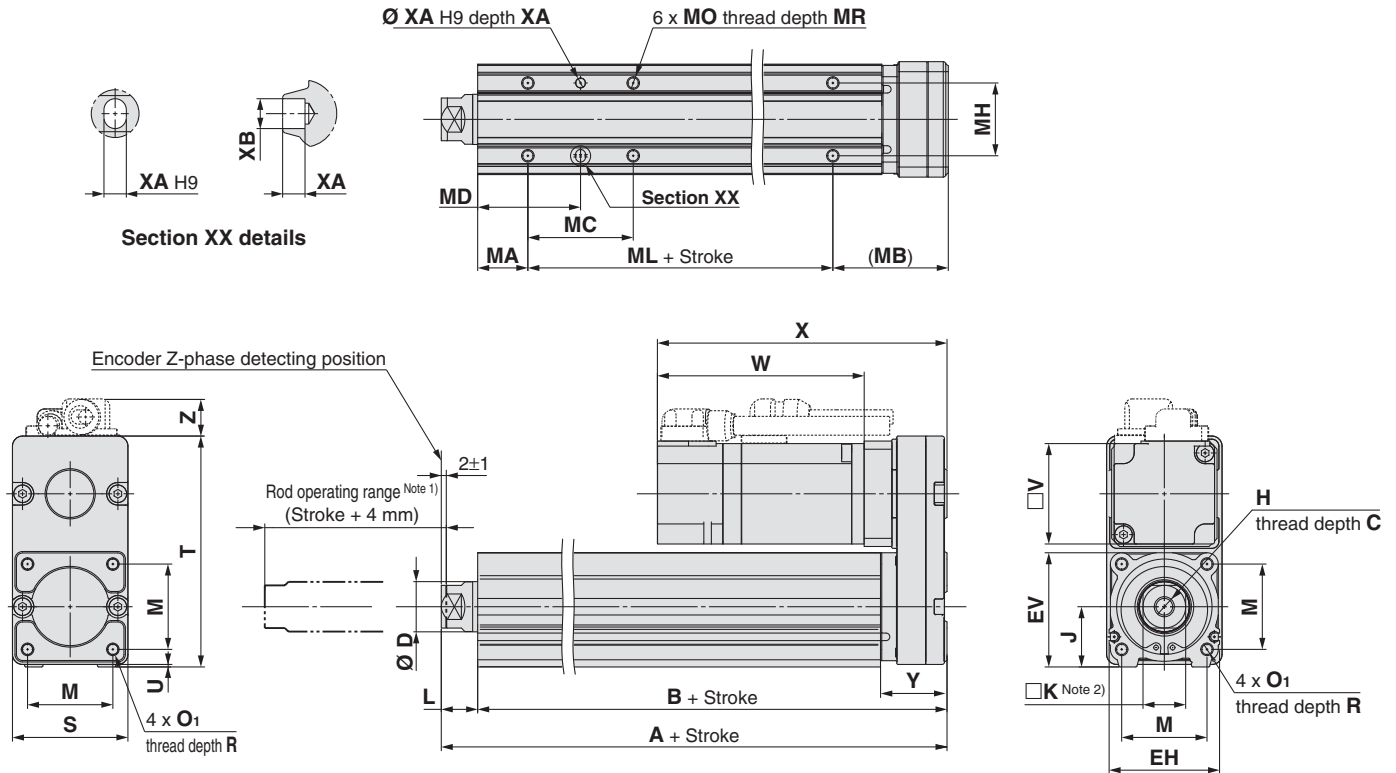

Note 1) Range within which the rod can move. Make sure a workpiece mounted on the rod does not interfere with the workpieces and facilities around the rod.

Note 2) The direction of rod end width across flats (\square K) differs depending on the products.

Size	Stroke range [mm]	A	B	C	D	EH	EV	H	J	K	L	M	O ₁	R	S
25	15 to 100	130.5	116	13	20	44	45.5	M8 x 1.25	24	17	14.5	34	M5 x 0.8	8	46
	105 to 400	155.5	141												
32	20 to 100	148.5	130	13	25	51	56.5	M8 x 1.25	31	22	18.5	40	M6 x 1.0	10	60
	105 to 500	178.5	160												

Size	Stroke range [mm]	T	U	Y	V	Incremental encoder						Absolute encoder					
						Without lock			With lock			Without lock			With lock		
						W	X	Z	W	X	Z	W	X	Z	W	X	Z
25	15 to 100	92	1	26.5	40	87	120	14.1	123.9	156.9	15.8	82.4	115.4	14.1	123.5	156.5	15.8
	105 to 400					87	120	14.1	123.9	156.9	15.8	82.4	115.4	14.1	123.5	156.5	15.8
32	20 to 100	118	1	34	60	88.2	128.2	17.1	116.8	156.8	17.1	76.6	116.6	17.1	116.1	156.1	17.1
	105 to 500					88.2	128.2	17.1	116.8	156.8	17.1	76.6	116.6	17.1	116.1	156.1	17.1

Body Bottom Tapped

Size	Stroke range [mm]	MA	MB	MC	MD	MH	ML	MO	MR	XA	XB
25	15 to 39	20	46	24	32	29	50	M5 x 0.8	6.5	4	5
	40 to 100			42	41						
	101 to 124			59	49.5						
	125 to 200			76	58						
	201 to 400			76	58						
32	20 to 39	25	55	22	36	30	50	M6 x 1	8.5	5	6
	40 to 100			36	43						
	101 to 124			53	51.5						
	125 to 200			53	51.5						
	201 to 500			70	60						

Dimensions: Motor Top/Parallel

Motor left side parallel type: **LEY²⁵₃₂L**

Motor right side parallel type: **LEY²⁵₃₂R**

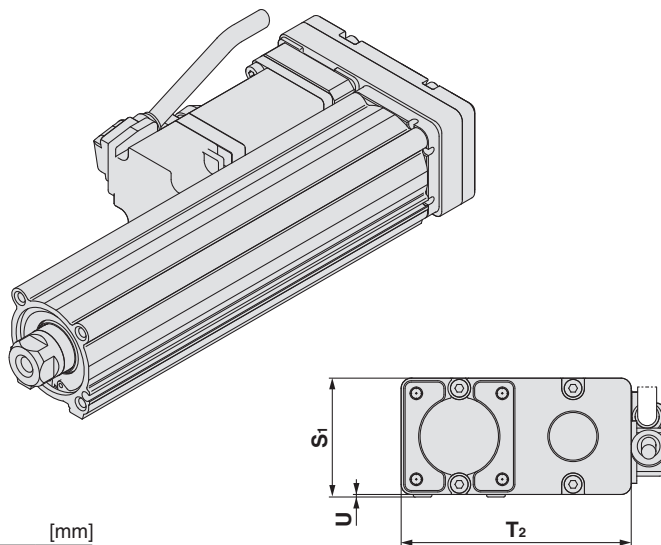
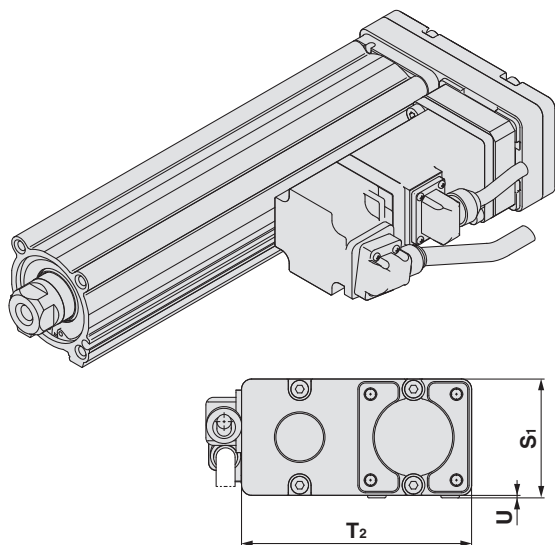

	[mm]		
Size	S ₁	T ₂	U
25	47	91	1
32	61	117	1

Note) When the motor is mounted on the left or right side in parallel, the groove for auto switch on the side to which the motor is mounted is hidden.

Model Selection

Servo Motor (24 VDC)/Step Motor (Servo/24 VDC)

LEY

LEYG

LECA6

LECP6

LEC-G

LECP1

LECPA

JXC□1

JXC7□□□□□□□□

AC Servo Motor

LEY

LEYG

LECS□

LECS-T

LECY□

Specific Product Precautions

Series LEY

AC Servo Motor

Size 25, 32

Dimensions: In-line Motor

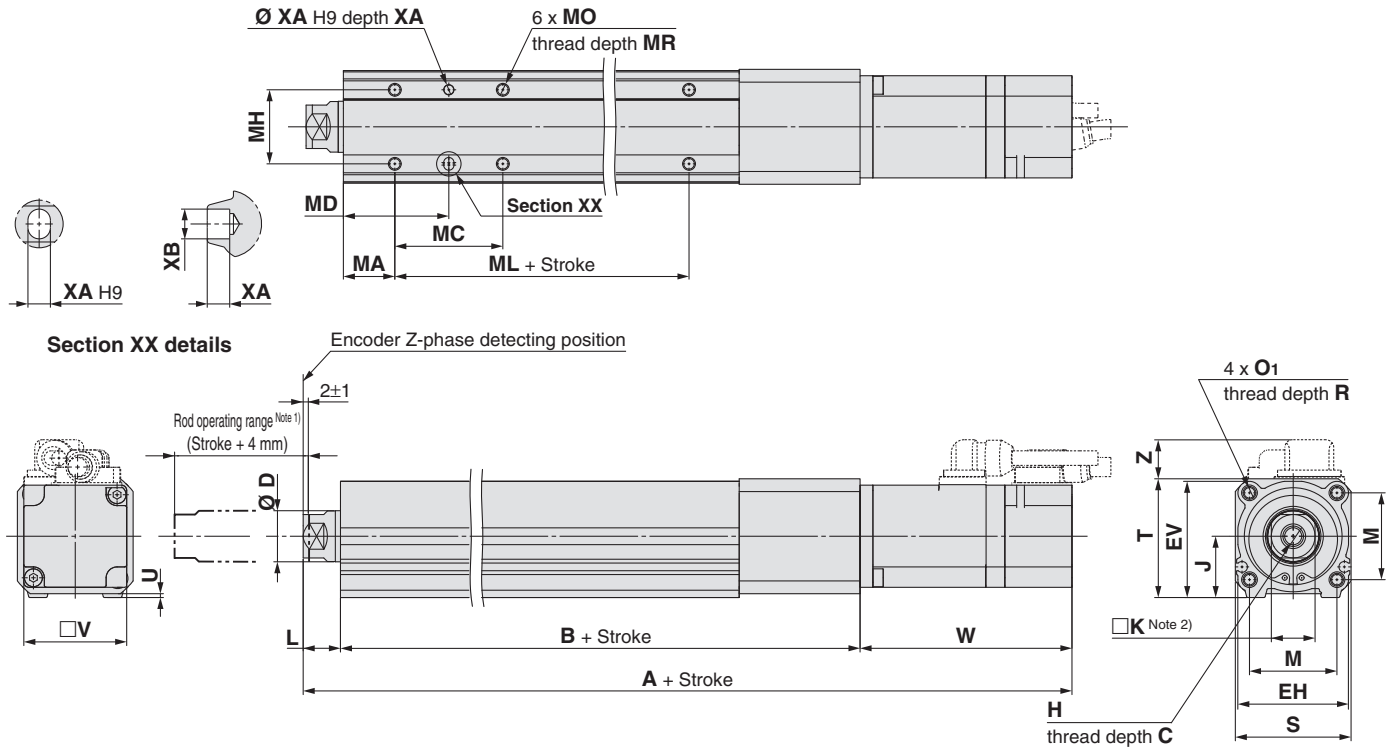

Note 1) Range within which the rod can move.

Make sure a workpiece mounted on the rod does not interfere with the workpieces and facilities around the rod.

Note 2) The direction of rod end width across flats (□K) differs depending on the products.

Size	Stroke range [mm]	C	D	EH	EV	H	J	K	L	M	O ₁	R	S	T	U
25	15 to 100	13	20	44	45.5	M8 x 1.25	24	17	14.5	34	M5 x 0.8	8	45	46.5	1.5
	105 to 400														
32	20 to 100	13	25	51	56.5	M8 x 1.25	31	22	18.5	40	M6 x 1.0	10	60	61	1
	105 to 500														

Size	Stroke range [mm]	B	V	Incremental encoder						Absolute encoder					
				Without lock			With lock			Without lock			With lock		
				A	W	Z	A	W	Z	A	W	Z	A	W	Z
25	15 to 100	136.5	40	238	87	14.6	274.9	123.9	16.3	233.4	82.4	14.6	274.5	123.5	16.3
	105 to 400	161.5		263			299.9			258.4			299.5		
32	20 to 100	156	60	262.7	88.2	17.1	291.3	116.8	17.1	251.1	76.6	17.1	290.6	116.1	17.1
	105 to 500	186		292.7			321.3			281.1			320.6		

Body Bottom Tapped

Size	Stroke range [mm]	MA	MC	MD	MH	ML	MO	MR	XA	XB
25	15 to 39	20	24	32	29	50	M5 x 0.8	6.5	4	5
	40 to 100		42	41		75				
	101 to 124		59	49.5						
	125 to 200		76	58						
	201 to 400									
32	20 to 39	25	22	36	30	50	M6 x 1	8.5	5	6
	40 to 100		36	43		80				
	101 to 124		53	51.5						
	125 to 200									
	201 to 500		70	60						

Dimensions

End male thread: LEY²⁵₃₂ □□ ^AB-□□M
C

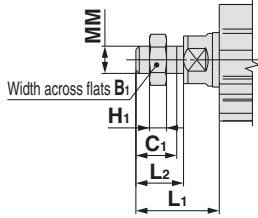

* Refer to page 25 for details about the rod end nut and mounting bracket.

Note) Refer to the precautions on page 169 when mounting end brackets such as knuckle joint or workpieces.

Size	B ₁	C ₁	H ₁	L ₁	L ₂	MM
25	22	20.5	8	38	23.5	M14 x 1.5
32	22	20.5	8	42.0	23.5	M14 x 1.5

[mm]

* The L₁ measurement is when the unit is in the original position. At this position, 2 mm at the end.

Foot: LEY²⁵₃₂ □□ ^AB-□□□□L
C

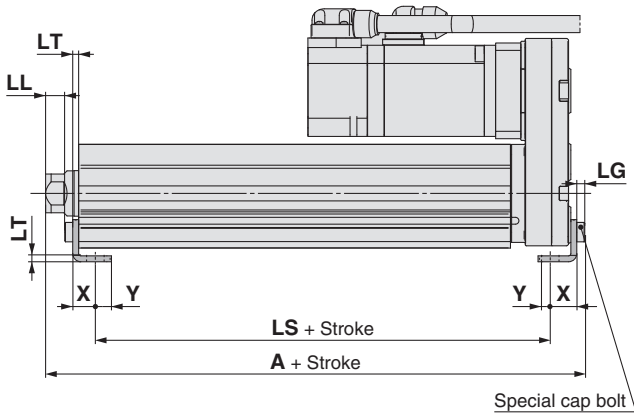

Special cap bolt

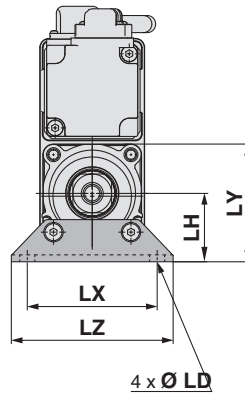

Included parts
• Foot
• Body mounting bolt

Outward mounting

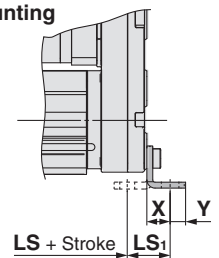

Foot

Size	Stroke range [mm]	A	LS	LS ₁	LL	LD	LG	LH	LT	LX	LY	LZ	X	Y
25	15 to 100	136.6	98.8	19.8	8.4	6.6	3.5	30	2.6	57	51.5	71	11.2	5.8
	101 to 400	161.6	123.8											
32	20 to 100	155.7	114	19.2	11.3	6.6	4	36	3.2	76	61.5	90	11.2	7
	101 to 500	185.7	144											

[mm]

Material: Carbon steel (Chromate treated)

* The A measurement is when the unit is in the Z-phase first detecting position. At this position, 2 mm at the end.

Note) When the motor mounting is the right or left side parallel type, the head side foot should be mounted outwards.

Model Selection

LEY

LEYG

LEYG

LECA6
LECP6

LEC-G

LECP1

LECPA

JXC□1

JXC7/3/3/3/3/3/3

LEY

LEYG

LECS□

LECS-T

LECY□

LECY□

Specific Product Precautions

Series LEY

AC Servo Motor

Size 25, 32

Dimensions

Rod flange: LEY²⁵₃₂ □ □ A B - □ □ □ F
C

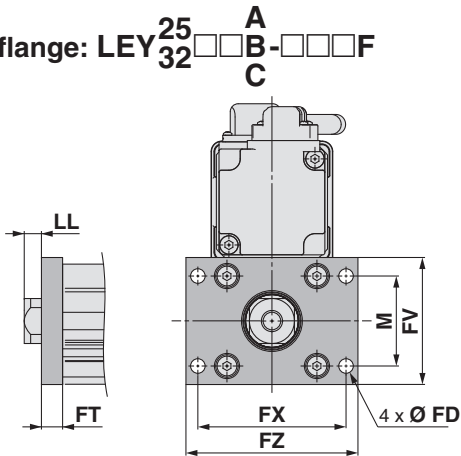

Head flange: LEY25 □ □ A B - □ □ □ G
C

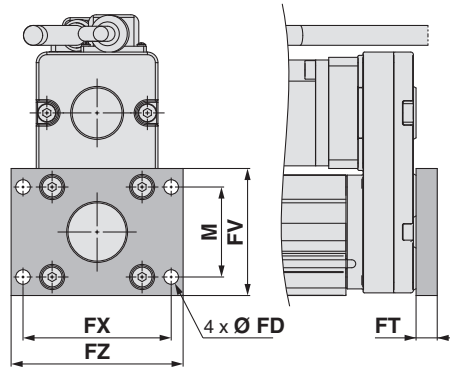

* Head flange is not available for the LEY32.

- Included parts
- Flange
 - Body mounting bolt

Rod/Head Flange [mm]

Size	FD	FT	FV	FX	FZ	LL	M
25	5.5	8	48	56	65	6.5	34
32	5.5	8	54	62	72	10.5	40

Material: Carbon steel (Nickel plated)

Double clevis: LEY²⁵₃₂ □ □ A B - □ □ □ D
C

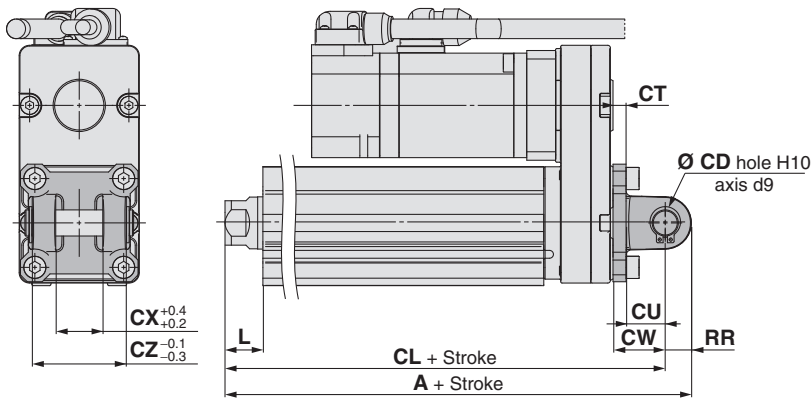

- Included parts
- Double clevis
 - Body mounting bolt
 - Clevis pin
 - Retaining ring

* Refer to page 25 for details about the rod end nut and mounting bracket.

Double Clevis [mm]

Size	Stroke range [mm]	A	CL	CD	CT
25	10 to 100	160.5	150.5	10	5
	101 to 200	185.5	175.5		
32	10 to 100	180.5	170.5	10	6
	101 to 200	210.5	200.5		

Size	Stroke range [mm]	CU	CW	CX	CZ	L	RR
25	10 to 100	14	20	18	36	14.5	10
	101 to 200						
32	10 to 100	14	22	18	36	18.5	10
	101 to 200						

Material: Cast iron (Coating)

* The A and CL measurements are when the unit is in the Z phase first detecting position. At this position, 2 mm at the end.

Specific Product
Precautions

LECY □

LECSS-T

LECS □

LEYG

LEYG

JXC7303/92/93

JXC □1

LECPA

LECP1

LEC-G

LECA6
LECP6

LEYG

LEYG

Model
Selection

Servo Motor (24 VDC)/Step Motor (Servo/24 VDC)

AC Servo Motor

Electric Actuator/ Rod Type

Dust/Drip proof (IP65 equivalent)

* Select options

Series **LEY** LEY63 Size **63**



How to Order

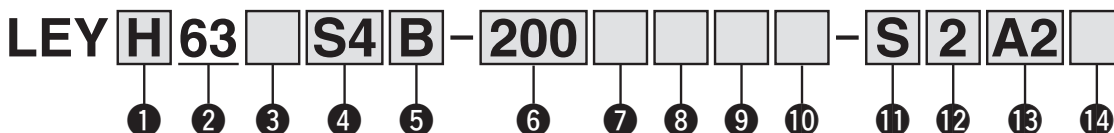

1 Accuracy

—	Basic type
H	High precision type

2 Size

63

3 Motor mounting position

—	Top mounting
R	Right side parallel
L	Left side parallel
D	In-line

4 Motor type*1

Symbol	Type	Output [W]	Actuator size	Compatible driver	UL-Compliant
S4	AC servo motor (Incremental encoder)	400	63	LECSA2-S4	—
S8	AC servo motor (Absolute encoder)	400	63	LECSB2-S8 LECSC2-S8 LECSS2-S8	—
T8	AC servo motor (Absolute encoder)	400	63	LECSS2-T8	●

5 Lead [mm]

Symbol	LEY63
A	20
B	10
C	5
L	2.86*

- * Screw lead 5 mm, Pulley ratio [4:7] equivalent lead
- * Only available for top mounting and right/left side parallel types.

6 Stroke [mm]

100	100
to	to
800	800

8 Motor option

—	Without option
B	With lock

9 Rod end thread

—	Rod end female thread
M	Rod end male thread (1 rod end nut is included.)

10 Mounting*1

Symbol	Type	Motor mounting position	
		Top/Parallel	In-line
—	Ends tapped/ Body bottom tapped *2	●	●
L	Foot	●	—
F	Rod flange*2	●	●
D	Double clevis*3	●	—

- *1 Mounting bracket is shipped together, (but not assembled).
- *2 For horizontal cantilever mounting with the rod flange and ends tapped, use the actuator within the following stroke range.
 - LEY63: 400 mm or less
- *3 For mounting with the double clevis, use the actuator within the following stroke range.
 - LEY63: 300 mm or less

7 Dust-tight/Water-jet-proof

—	IP5x equivalent (Dust-protected)
P	IP65 equivalent (Dust-tight/Water-jet-proof)/ With vent hole tap

- * When using the dust-tight/water-jet-proof (IP65 equivalent), correctly mount the fitting and tubing to the vent hole tap, and then place the end of the tubing in an area not exposed to dust or water.
- * The fitting and tubing should be provided separately by the customer. Select [Applicable tubing O.D.: Ø 4 or more, Connection thread: Rc1/8].
- * Cannot be used in environments exposed to cutting oil etc. Take suitable protective measures.

12 Cable length ^{Note 2)} [m]

—	Without cable
2	2
5	5
A	10

Note 2) The length of the encoder, motor and lock cables are the same.

11 Cable type ^{Note 1)}

—	Without cable
S	Standard cable
R	Robotic cable (Flexible cable)

- Note 1) The motor and encoder cables are included. (The lock cable is also included when the motor with lock option is selected.)
- * Standard cable entry direction is
 - Top/Parallel: (A) Axis side
 - In-line: (B) Counter axis side
 (Refer to page 185 for details.)

14 I/O cable length [m]*

—	Without cable
H	Without cable (Connector only)
1	1.5

- * When "Without driver" is selected for driver type, only "—": Without cable" can be selected. Refer to page 186 if I/O cable is required. (Options are shown on page 186.)

13 Driver type

	Compatible driver	Power supply voltage	UL-Compliant
—	Without driver		—
A2	LECSA2/Pulse input (Incremental encoder)	200 V to 230 V	—
B2	LECSB2/Pulse input (Absolute encoder)	200 V to 230 V	—
C2	LECSC2/CC-Link (Absolute encoder)	200 V to 230 V	—
S2	LECSS2-S/SSCNET III (Absolute encoder)	200 V to 230 V	—
	LECSS2-T/SSCNET III/H (Absolute encoder)	200 V to 240 V	●

- * When the driver type is selected, the cable is included. Select cable type and cable length.
- Example)
 S2S2: Standard cable (2 m) + Driver (LECSS2)
 S2 : Standard cable (2 m)
 — : Without cable and driver

* Applicable stroke table

Model	Stroke [mm]	50	100	150	200	250	300	350	400	450	500	600	700	800	Manufacturable stroke range
LEY63		●	●	●	●	●	●	●	●	●	●	●	●	●	50 to 800

Note) Please consult with SMC for non-standard strokes as they are produced as special orders.

Electric Actuator/Rod Type **Series LEY**

AC Servo Motor

Size **63**

Dust/Drip proof (IP65 equivalent)

* Select options

Specifications

Model		LEY63S ₈ ⁴ □ (Top/Parallel)					LEY63DS ₈ ⁴ □ (In-line)		
Stroke [mm] ^{Note 1)}		50, 100, 150, 200, 250, 300, 350, 400, 450, 500, 600, 700, 800							
Work load [kg]	Horizontal ^{Note 2)}	40	70	80	200	40	70	80	
	Vertical ^{Note 9)}	19	38	72	115	19	38	72	
Force [N]/Set value ^{Note 3)} : 15 to 50 % ^{Note 4)}		156 to 521	304 to 1012	573 to 1910	1003 to 3343	156 to 521	304 to 1012	573 to 1910	
Max. speed [mm/s] ^{Note 5)}	Stroke range	Up to 500	1000	500	250	70	1000	500	250
		505 to 600	800	400	200		800	400	200
		605 to 700	600	300	150		600	300	150
		705 to 800	500	250	125		500	250	125
Pushing speed [mm/s] ^{Note 6)}		30 or less							
Max. acceleration/deceleration [mm/s ²]		5000			3000	5000			
Positioning repeatability [mm]	Basic type	±0.02							
	High precision type	±0.01							
Lost motion [mm] ^{Note 7)}	Basic type	0.1 or less							
	High precision type	0.05 or less							
Screw lead [mm] (including pulley ratio)		20	10	5	5 (2.86)	20	10	5	
Impact/Vibration resistance [m/s ²] ^{Note 8)}		50/20							
Actuation type		Ball screw			Ball screw + Belt (Pulley ratio 4:7)	Ball screw			
Guide type		Sliding bushing (Piston rod)							
Operating temperature range [°C]		5 to 40							
Operating humidity range [%RH]		90 or less (No condensation)							
Regeneration option		May be required depending on speed and work load. (Refer to LEY catalogue conditions for "Regeneration Option")							
Motor output/Size		400 W/□60							
Motor type		AC servo motor (200 VAC)							
Encoder		Motor type S4: Incremental 17-bit encoder (Resolution: 131072 p/rev) Motor type S8: Absolute 18-bit encoder (Resolution: 262144 p/rev)							
Power consumption [W] ^{Note 10)}	Horizontal	210							
	Vertical	230							
Standby power consumption when operating [W] ^{Note 11)}	Horizontal	2							
	Vertical	18							
Max. instantaneous power consumption [W] ^{Note 12)}		1275							
Type ^{Note 13)}		Non-magnetizing lock							
Holding force [N]		313	607	1146	2006	313	607	1146	
Power consumption [W] at 20 °C ^{Note 14)}		7.9							
Rated voltage [V]		24 VDC ₋₁₀ ⁰ %							

Note 1) Please consult with SMC for non-standard strokes as they are produced as special orders.

Note 2) The maximum value of the horizontal work load. An external guide is necessary to support the load. The actual work load changes according to the condition of the external guide. Please confirm using actual device.

Note 3) Set values for the driver.

Note 4) The force setting range (set values for the driver) for the force control with the torque control mode. The force and duty ratio change according to the set value. Set it with reference to "Force Conversion Graph" on page 131. When the control equivalent to the pushing operation of the controller LECP series is performed, select the LECS driver and combine it with the Simple Motion (manufactured by Mitsubishi Electric Corporation) which has a pushing operation function.

Note 5) The allowable speed changes according to the stroke. Set the number of rotations according to speed.

Note 6) The allowable collision speed for collision with the workpiece with the torque control mode.

Note 7) A reference value for correcting an error in reciprocal operation.

Note 8) Impact resistance: No malfunction occurred when the actuator was tested with a drop tester in both an axial direction and a perpendicular direction to the lead screw. (Test was performed with the actuator in the initial state.)

Vibration resistance: No malfunction occurred in a test ranging between 45 to 2000 Hz. Test was performed in both an axial direction and a perpendicular direction to the lead screw. (Test was performed with the actuator in the initial state.)

Note 9) When mounting vertically and using the product facing upwards in an environment where water is present, take necessary measures to prevent water from splashing on the rod cover, because water will accumulate on the rod seal due to the structure of the product.

Note 10) The power consumption (including the driver) is for when the actuator is operating.

Note 11) The standby power consumption when operating (including the driver) is for when the actuator is stopped in the set position during the operation.

Note 12) The maximum instantaneous power consumption (including the driver) is for when the actuator is operating.

Note 13) Only when motor option "With lock" is selected.

Note 14) For an actuator with lock, add the power consumption for the lock.

Weight

Product Weight [kg]

Series		LEY63S ₈ ⁴ (Motor mounting position: Top/Parallel)												
Stroke [mm]		50	100	150	200	250	300	350	400	450	500	600	700	800
Motor type	Incremental encoder	4.9	5.4	6.0	6.6	7.8	8.3	8.9	9.4	10.0	10.5	12.2	13.4	14.5
	Absolute encoder (Motor type S8)	5.0	5.5	6.1	6.7	7.9	8.4	9.0	9.5	10.1	10.6	12.3	13.5	14.6
	Absolute encoder (Motor type T8)	4.9	5.4	6.0	6.6	7.8	8.3	8.9	9.4	10.0	10.5	12.2	13.4	14.5

Series		LEY63DS ₈ ⁴ (Motor mounting position: In-line)												
Stroke [mm]		50	100	150	200	250	300	350	400	450	500	600	700	800
Motor type	Incremental encoder	5.1	5.6	6.2	6.7	7.9	8.4	9.0	9.6	10.2	10.7	12.4	13.5	14.7
	Absolute encoder (Motor type S8)	5.2	5.7	6.3	6.8	8.0	8.5	9.1	9.7	10.3	10.8	12.5	13.6	14.8
	Absolute encoder (Motor type T8)	5.1	5.6	6.2	6.7	7.9	8.4	9.0	9.6	10.2	10.7	12.4	13.5	14.7

Additional Weight [kg]

Size		63
Lock	Incremental encoder	0.4
	Absolute encoder (Motor type S8)	0.6
	Absolute encoder (Motor type T8)	0.4
Rod end male thread	Male thread	0.12
	Nut	0.04
Foot (2 sets including mounting bolt)		0.26
Rod flange (including mounting bolt)		0.51
Double clevis (including pin, retaining ring and mounting bolt)		0.58

Model Selection

LEY

LEYG

LECA6
LECP6

LECG

LECP1

LECPA

JXC□1

JXC7/8/9/2/8

LEY

AC Servo Motor

LEYG

LECS□

LECS-T

LECY□

Specific Product Precautions

Series LEY

AC Servo Motor

Size **63**

Dust/Drip proof (IP65 equivalent)

* Select options

Construction

Motor top mounting type: LEY63

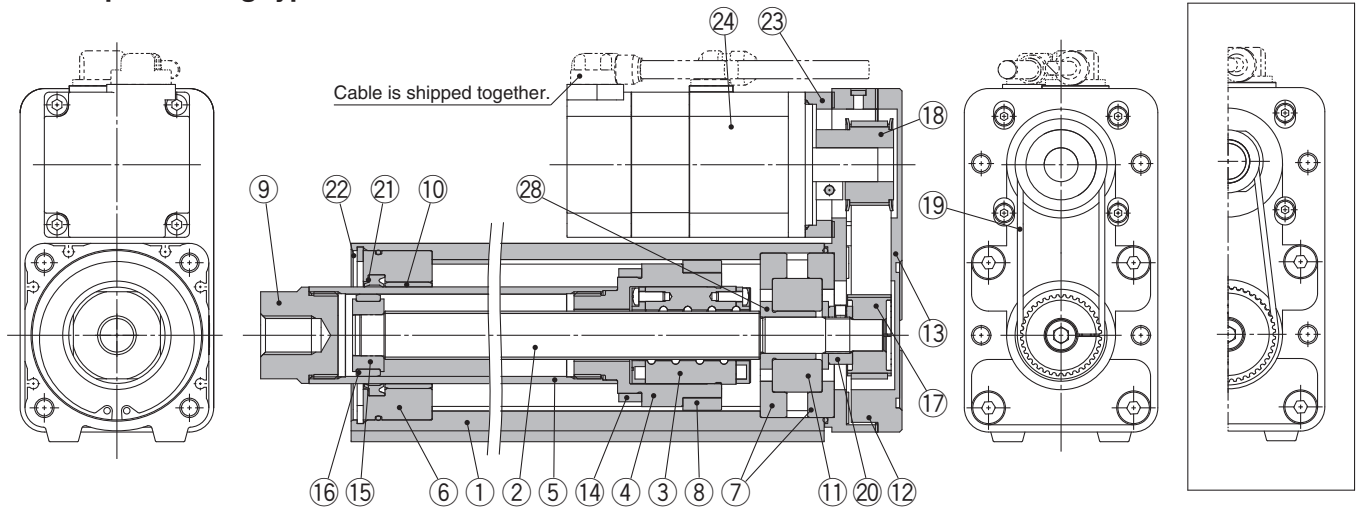

In-line motor type: LEY63D

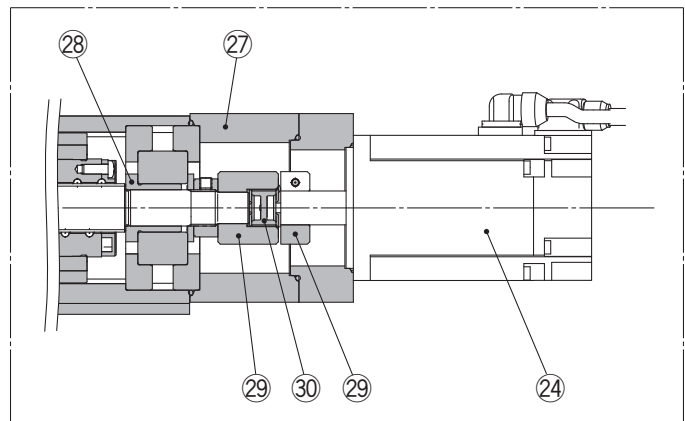
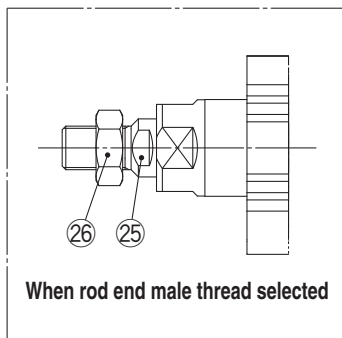

Component Parts

No.	Description	Material	Note
1	Body	Aluminium alloy	Anodised
2	Ball screw shaft	Alloy steel	
3	Ball screw nut	Resin/Alloy steel	
4	Piston	Aluminium alloy	
5	Piston rod	Stainless steel	Hard chrome plating
6	Rod cover	Aluminium alloy	
7	Bearing holder	Aluminium alloy	
8	Rotation stopper	Resin	
9	Socket	Free cutting carbon steel	Nickel plating
10	Bushing	Lead bronze cast	
11	Bearing	—	
12	Return box	Aluminium alloy	Coating
13	Return plate	Aluminium alloy	Coating
14	Magnet	—	
15	Wear ring holder	Stainless steel	

No.	Description	Material	Note
16	Wear ring	Resin	
17	Screw shaft pulley	Aluminium alloy	
18	Motor pulley	Aluminium alloy	
19	Belt	—	
20	Lock nut	Alloy steel	Black dyed
21	Seal	NBR	
22	Retaining ring	Steel for spring	
23	Motor adapter	Aluminium alloy	Coating
24	Motor	—	
25	Socket (Male thread)	Free cutting carbon steel	Nickel plating
26	Nut	Alloy steel	Trivalent chromated
27	Motor block	Aluminium alloy	Coating
28	Spacer A	Stainless steel	
29	Hub	Aluminium alloy	
30	Spider	Urethane	

Replacement Parts (Top/Parallel only)/Belt

No.	Size	Lead	Order no.
19	63	A/B/C	LE-D-2-5
		L	LE-D-2-6

Replacement Parts/Grease Pack

Applied portion	Order no.
Piston rod	GR-S-010 (10 g) GR-S-020 (20 g)

* Apply grease on the piston rod periodically.
Grease should be applied at 1 million cycles or 200 km, whichever comes first.

* Select options

Dimensions: Motor Top/Parallel

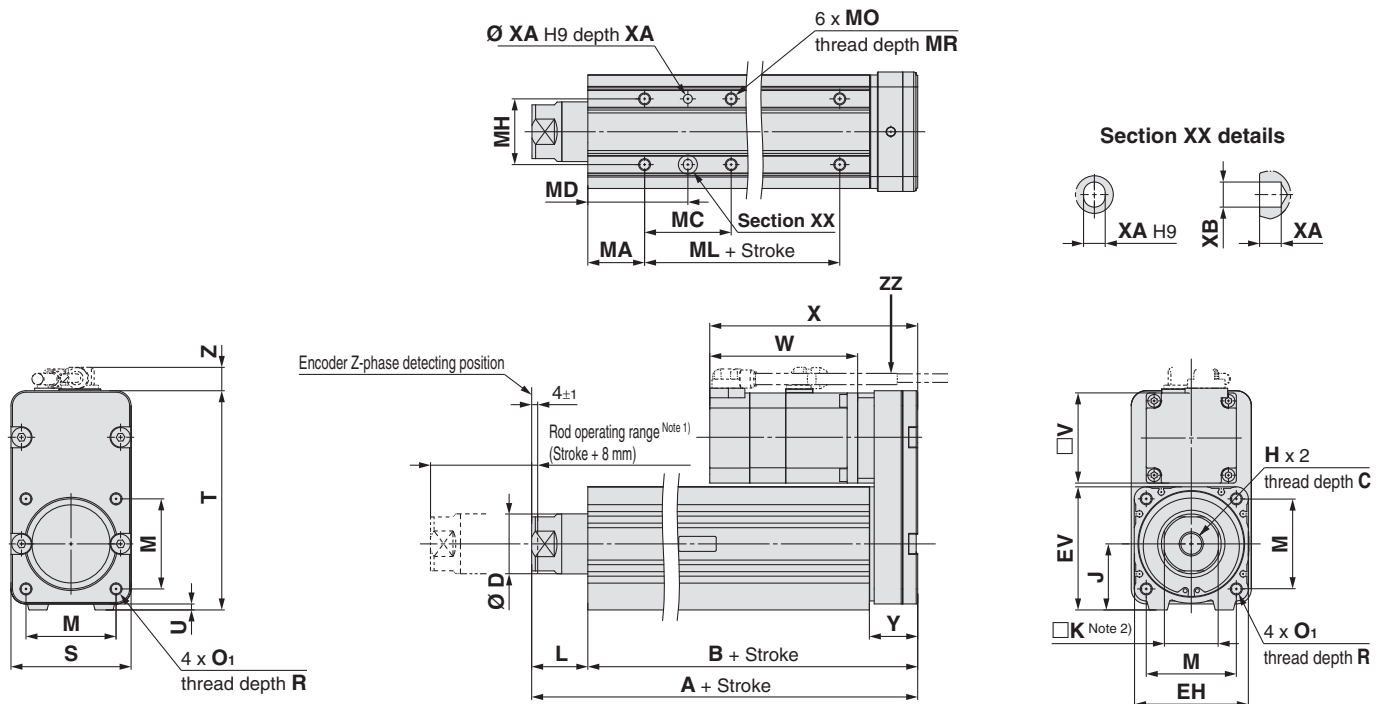

Note 1) Range within which the rod can move.

Make sure a workpiece mounted on the rod does not interfere with the workpieces and facilities around the rod.

Note 2) The direction of rod end width across flats (□K) differs depending on the products.

IP65 equivalent (Dust-tight/Water-jet-proof): LEY63□□□□-□P

(View ZZ)

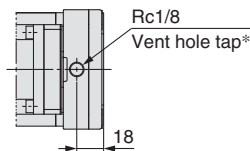

* When using the dust-tight/water-jet-proof (IP65 equivalent), correctly mount the fitting and tubing to the vent hole tap, and then place the end of the tubing in an area not exposed to dust or water. The fitting and tubing should be provided separately by the customer.

Select [Applicable tubing O.D.: Ø 4 or more, Connection thread: Rc1/8].

Size	Stroke range [mm]	A	B	C	D	EH	EV	H	J	K	L	M	O ₁	R	S	Y
63	Up to 200	192.6	155.2	21	40	76	82	M16 x 2	44	36	37.4	60	M8 x 1.25	16	80	32.2
	205 to 500	227.6	190.2													
	505 to 800	262.6	225.2													

Size	Stroke range [mm]	T	U	V	Incremental encoder						Absolute encoder							
					Without lock			With lock			Without lock			With lock				
					W	X	Z	W	X	Z	W	X	Z	W	X	Z		
63	Up to 200	146	4	60	110.2	150.2	15.6 (16.6)*	138.8	178.8	15.6 (16.6)*	98.5	138.5	15.6 (16.6)*	138	178	15.6 (16.6)*		
	205 to 500																	
	505 to 800																	

* The values in () are the dimensions when L is selected for screw lead.

Body Bottom Tapped

Size	Stroke range [mm]	MA	MC	MD	MH	ML	MO	MR	XA	XB	
63	50 to 74	38	24	50	44	65	M8 x 1.25	10	6	7	
	75 to 124		45	60.5							
	125 to 200		58	67							
	201 to 500		86	81							100
	501 to 800										135

Model Selection
 LEY
 LEYG
 LECA6
 LECP6
 LEC-G
 LEC-P1
 LEC-PA
 JXC□1
 JXC7□□□□□□□□
 AC Servo Motor
 LEY
 LEYG
 LECS□
 LECS-T
 LECY□
 Specific Product Precautions

Series LEY

AC Servo Motor

Size **63**

Dust/Drip proof (IP65 equivalent)

* Select options

Dimensions: Motor Top/Parallel

Motor left side parallel type: LEY63L

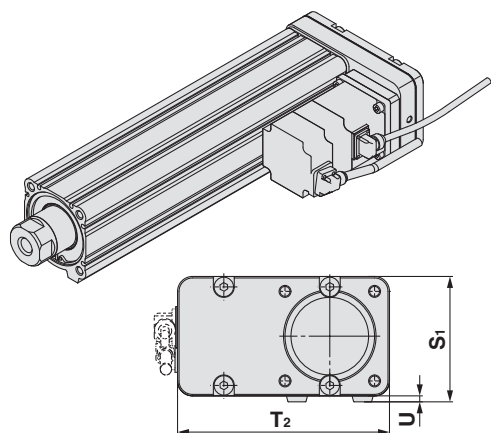

Motor right side parallel type: LEY63R

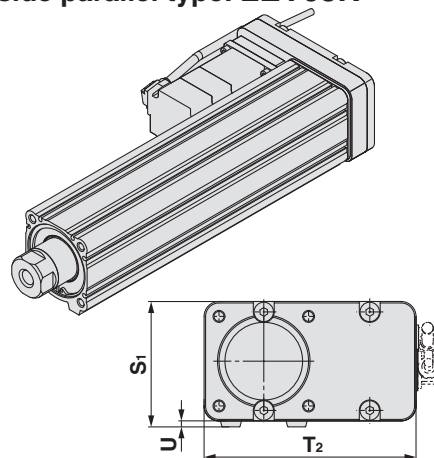

Size	S ₁	T ₂	U
63	84	142	4

[mm]

Note) When the motor is mounted on the left or right side in parallel, the groove for auto switch on the side to which the motor is mounted is hidden.

Electric Actuator/Rod Type **Series LEY**

AC Servo Motor

Size **63**

Dust/Drip proof (IP65 equivalent)

* Select options

Dimensions: In-line Motor

LEY63D□

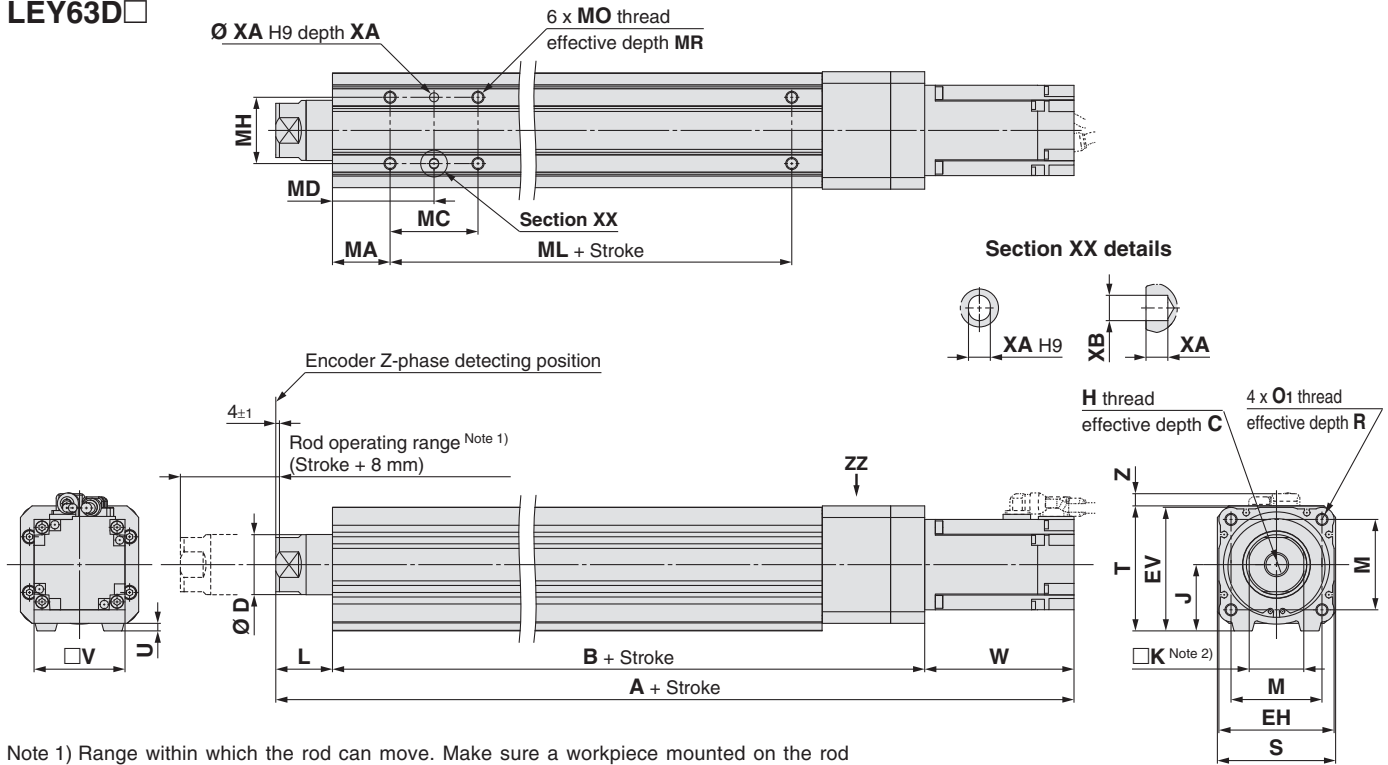

Note 1) Range within which the rod can move. Make sure a workpiece mounted on the rod does not interfere with the workpieces and facilities around the rod.

Note 2) The direction of rod end width across flats (□K) differs depending on the products.

Size	Stroke range [mm]	C	D	EH	EV	H	J	K	L	M	O ₁	R	S	T	U
63	Up to 200	21	40	76	82	M16 x 2	44	36	37.4	60	M8 x 1.25	16	78	83	5
	205 to 500														
	505 to 800														

Size	Stroke range [mm]	B	V	Incremental encoder						Absolute encoder					
				Without lock			With lock			Without lock			With lock		
				A	W	Z	A	W	Z	A	W	Z	A	W	Z
63	Up to 200	190.7	60	338.3	110.2	8.1	366.9	138.8	8.1	326.6	98.5	8.1	366.1	138	8.1
	205 to 500	225.7		373.3			401.9			361.6			401.1		
	505 to 800	260.7		408.3			436.9			396.6			436.1		

Body Bottom Tapped

Size	Stroke range [mm]	MA	MC	MD	MH	ML	MO	MR	XA	XB	
63	50 to 74	38	24	50	44	65	M8 x 1.25	10	6	7	
	75 to 124		45	60.5							
	125 to 200		58	67							
	201 to 500		86	81							100
	501 to 800										135

IP65 equivalent (Dust-tight/Water-jet-proof): LEY63D□□-□P (View ZZ)

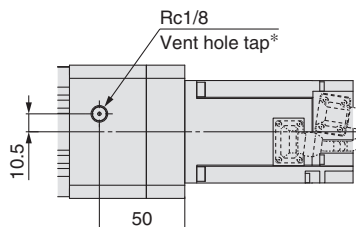

* When using the dust-tight/water-jet-proof (IP65 equivalent), correctly mount the fitting and tubing to the vent hole tap, and then place the end of the tubing in an area not exposed to dust or water. The fitting and tubing should be provided separately by the customer. Select [Applicable tubing O.D.: Ø 4 or more, Connection thread: Rc1/8].

Model Selection

LEY

LEYG

LECA6
LECP6

LEC-G

LECP1

LECPA

JXC□1

JXC73/83/92/93

LEY

LEYG

LECS□

LECS-T

LECY□

Specific Product Precautions

Series LEY

AC Servo Motor

Size **63**

Dust/Drip proof (IP65 equivalent)

* Select options

Dimensions

End male thread: LEY63□□□-□□M

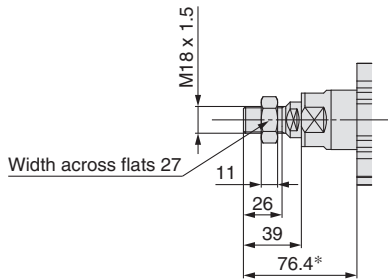

* The measurement 76.4 is when the unit is in the Z-phase detecting position. At this position, 4 mm from the end of the operating range.

Foot: LEY63□□□-□□L

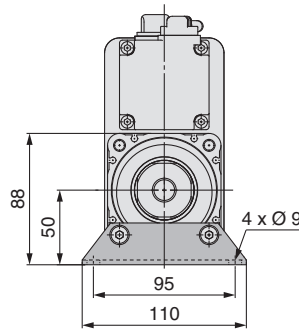
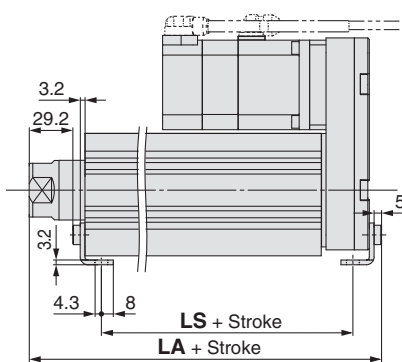

Outward mounting

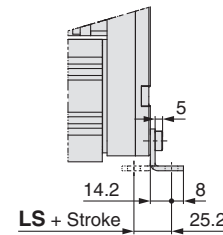

Included parts
• Foot
• Body mounting bolt

Material: Carbon steel (Chromate treated)
* The overall length is when the unit is in the Z-phase detecting position. At this position, 4 mm from the end of the operating range.
Note) When the motor mounting is the right or left side parallel type, the head side foot should be mounted outwards.

	[mm]	
Stroke range [mm]	LA	LS
50 to 200	200.8	133.2
201 to 500	235.8	168.2
501 to 800	270.8	203.2

Rod flange: LEY63□□□-□□F

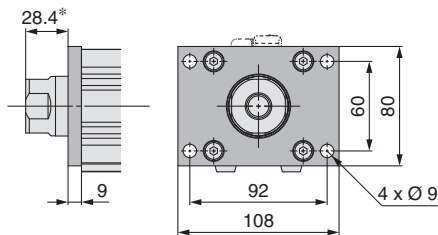

Included parts
• Flange
• Body mounting bolt

Material: Carbon steel (Nickel plating)
* When the unit is in the Z-phase detecting position. At this position, 4 mm from the end of the operating range.

Double clevis: LEY63□□□-□□D

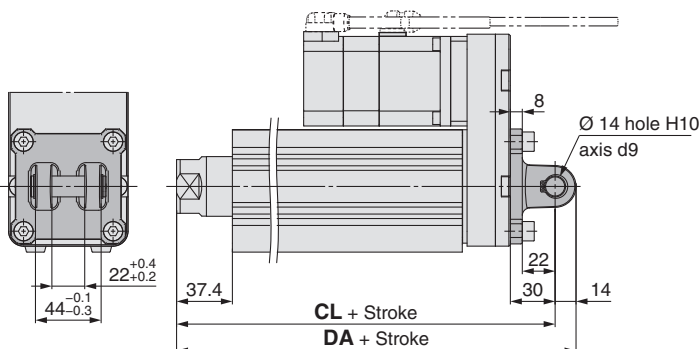

Included parts
• Double clevis
• Body mounting bolt
• Clevis pin
• Retaining ring

Material: Cast iron (Coating)
* The overall length is when the unit is in the Z-phase detecting position. At this position, 4 mm from the end of the operating range.

	[mm]	
Stroke range [mm]	DA	CL
50 to 200	236.6	222.6
201 to 500	271.6	257.6
501 to 800	306.6	292.6

Electric Actuator/ Rod Type

Dust/Drip proof (IP65 Equivalent)

LEY-X5 (Made to Order) Series LEY25, 32



RoHS

Model Selection

LEY

LEYG

LECA6
LECP6

LEC-G

LECP1

LECPA

JXC1

JXC7303/92/93

LEY

LEYG

LECS

LECS-T

LECY

Specific Product Precautions

How to Order

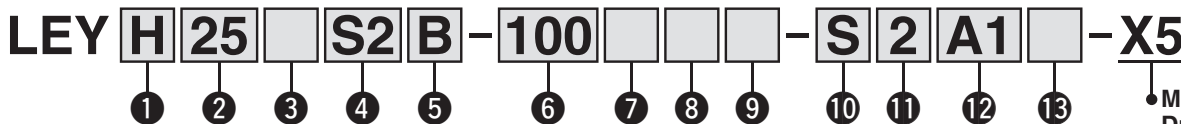

Made to Order:
Dust-tight/
Water-jet-proof

① Accuracy

—	Basic type
H	High precision type

② Size

25
32

③ Motor mounting position

—	Top mounting
D	In-line

④ Motor type*

Symbol	Type	Output [W]	Actuator size	Compatible driver
S2	AC servo motor (Incremental encoder)	100	25	LECSA□-S1
S3	AC servo motor (Incremental encoder)	200	32	LECSA□-S3
S6	AC servo motor (Absolute encoder)	100	25	LECSB□-S5 LECSS□-S5 LECS□-S5
S7	AC servo motor (Absolute encoder)	200	32	LECSB□-S7 LECSS□-S7 LECS□-S7

* For motor type S2 and S6, the compatible driver part number suffixes are S1 and S5 respectively.

⑤ Lead [mm]

Symbol	LEY25□	LEY32□*
A	12	16 (20)
B	6	8 (10)
C	3	4 (5)

* The values shown in () are the equivalent lead which includes the pulley ratio for size 32 top mounting type.

⑥ Stroke [mm]

30	30
to	to
500	500

* Refer to the applicable stroke table.

⑦ Motor option

—	Without option
B	With lock*

* When "With lock" is selected for the top mounting type, the motor body will stick out of the end of the body for size 25 with strokes 30 mm or less. Check for interference with workpieces before selecting a model.

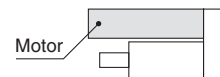

⑧ Rod end thread

—	Rod end female thread
M	Rod end male thread (1 rod end nut is included.)

⑨ Mounting*1

Symbol	Type	Motor mounting position	
		Top mounting	In-line
—	Ends tapped/ Body bottom tapped*2	●	●
L	Foot	●	—
F	Rod flange*2	●*3	●
G	Head flange*2	●*4	—

*1 Mounting bracket is shipped together, (but not assembled).

*2 For horizontal cantilever mounting with the rod flange, head flange and ends tapped, use the actuator within the following stroke range.

- LEY25: 200 mm or less
- LEY32: 100 mm or less

*3 Rod flange is not available for the LEY25 with stroke 30 mm and motor option "With lock".

*4 Head flange is not available for the LEY32.

⑩ Cable type*

—	Without cable
S	Standard cable
R	Robotic cable (Flexible cable)

* The motor and encoder cables are included. (The lock cable is also included when the motor with lock option is selected.)

- * Standard cable entry direction is
 - Top mounting: (A) Axis side
 - In-line: (B) Counter axis side
 (Refer to page 185 for details.)

⑪ Cable length [m]*

—	Without cable
2	2
5	5
A	10

* The length of the encoder, motor and lock cables are the same.

⑬ I/O cable length [m]*

—	Without cable
H	Without cable (Connector only)
1	1.5

* When "Without driver" is selected for driver type, only "—: Without cable" can be selected. Refer to page 186 if I/O cable is required. (Options are shown on page 186.)

* Applicable Stroke Table

Model	Stroke											Manufacturable stroke range [mm]
	30	50	100	150	200	250	300	350	400	450	500	
LEY25	●	●	●	●	●	●	●	●	●	—	—	15 to 400
LEY32	●	●	●	●	●	●	●	●	●	●	●	20 to 500

* Please consult with SMC for non-standard strokes as they are produced as special orders.

⑫ Driver type*

	Compatible driver	Power supply voltage [V]
—	Without driver	—
A1	LECSA1	100 to 120
A2	LECSA2	200 to 230
B1	LECSB1	100 to 120
B2	LECSB2	200 to 230
C1	LECSA1	100 to 120
C2	LECSA2	200 to 230
S1	LECSS1	100 to 120
S2	LECSS2	200 to 230

* When the driver type is selected, the cable is included. Select cable type and cable length. Example)
S2S2: Standard cable (2 m) + Driver (LECSS2)
S2 : Standard cable (2 m)
— : Without cable and driver

* For auto switches, refer to page 36.

Series LEY-X5

AC Servo Motor

Dust/Drip proof (IP65 equivalent)

Specifications

Model		LEY25S ₆ ² /LEY25DS ₆ ²				LEY32S ₇ ³ (Top mounting)				LEY32DS ₇ ³ (In-line)			
Actuator specifications	Stroke [mm] ^{Note 1)}	30, 50, 100, 150, 200 250, 300, 350, 400				30, 50, 100, 150, 200, 250 300, 350, 400, 450, 500				30, 50, 100, 150, 200, 250 300, 350, 400, 450, 500			
	Work load [kg]	Horizontal ^{Note 2)}				30				30			
		Vertical ^{Note 10)}				9				12			
	Force [N] ^{Note 3)} (Set value: 15 to 30 %)	65 to 131	127 to 255	242 to 485	79 to 157	154 to 308	294 to 588	98 to 197	192 to 385	368 to 736			
	Max. speed ^{Note 4)} [mm/s]	Stroke range	Up to 300	900	450	225	1200	600	300	1000	500	250	
			305 to 400	600	300	150							
			405 to 500	—	—	—							
	Pushing speed [mm/s] ^{Note 5)}	35 or less				30 or less				30 or less			
	Max. acceleration/deceleration [mm/s ²]	5000				5000							
	Positioning repeatability [mm]	Basic type				±0.02							
		High precision type				±0.01							
	Lost motion [mm] ^{Note 6)}	Basic type				0.1 or less							
		High precision type				0.05 or less							
	Lead [mm]	12	6	3	20 ^{Note 7)}	10 ^{Note 7)}	5 ^{Note 7)}	16	8	4			
	Impact/Vibration resistance [m/s ²] ^{Note 8)}	50/20				50/20							
Actuation type	Ball screw + Belt/Ball screw				Ball screw + Belt				Ball screw				
Guide type	Sliding bushing (Piston rod)				Sliding bushing (Piston rod)								
Enclosure ^{Note 9)}	IP65 equivalent												
Operating temperature range [°C]	5 to 40				5 to 40								
Operating humidity range [%RH]	90 or less (No condensation)				90 or less (No condensation)								
Regeneration option	May be required depending on speed and work load. (Refer to LEY catalogue conditions for "Regeneration Option")												
Motor output/Size	100 W/□40				200 W/□60								
Motor type	AC servo motor (100/200 VAC)				AC servo motor (100/200 VAC)								
Encoder	Motor type S2, S3: Incremental 17-bit encoder (Resolution: 131072 p/rev) Motor type S6, S7: Absolute/incremental dual 18-bit encoder (Resolution: 262144 p/rev)												
Power consumption [W] ^{Note 11)}	Horizontal				65				65				
	Vertical				175				175				
Standby power consumption when operating [W] ^{Note 12)}	Horizontal				2				2				
	Vertical				8				8				
Max. instantaneous power consumption [W] ^{Note 13)}	445				724				724				
Type ^{Note 14)}	Non-magnetizing lock												
Holding force [N]	131	255	485	157	308	588	197	385	736				
Power consumption [W] at 20 °C ^{Note 15)}	6.3				7.9				7.9				
Rated voltage [V]	24 VDC												

Note 1) Please consult with SMC for non-standard strokes as they are produced as special orders.

Note 2) The maximum value of the horizontal work load. An external guide is necessary to support the load. The actual work load changes according to the condition of the external guide. Please confirm using actual device.

Note 3) The force setting range (set values for the driver) for the force control with the torque control mode. Set it with reference to "Force Conversion Graph" on page 131. When the control equivalent to the pushing operation of the controller LECP series is performed, select the LECSS driver and combine it with the Simple Motion (manufactured by Mitsubishi Electric Corporation) which has a pushing operation function.

Note 4) The allowable speed changes according to the stroke. Set the number of rotations according to speed.

Note 5) The allowable collision speed for collision with the workpiece with the torque control mode.

Note 6) A reference value for correcting an error in reciprocal operation.

Note 7) Equivalent lead which includes the pulley ratio [1.25:1]

Note 8) Impact resistance: No malfunction occurred when the actuator was tested with a drop tester in both an axial direction and a perpendicular direction to the lead screw. (Test was performed with the actuator in the initial state.)

Vibration resistance: No malfunction occurred in a test ranging between 45 to 2000 Hz. Test was performed in both an axial direction and a perpendicular direction to the lead screw. (Test was performed with the actuator in the initial state.)

Note 9) Cannot be used in an environment where oil such as cutting oil splashes or it is constantly exposed to water. Take suitable protective measures.

Note 10) When mounting vertically and using the product facing upwards in an environment where water is present, take necessary measures to prevent water from splashing on the rod cover, because water will accumulate on the rod seal due to the structure of the product.

Note 11) The power consumption (including the driver) is for when the actuator is operating.

Note 12) The standby power consumption when operating (including the driver) is for when the actuator is stopped in the set position during the operation.

Note 13) The maximum instantaneous power consumption (including the driver) is for when the actuator is operating.

Note 14) Only when motor option "With lock" is selected.

Note 15) For an actuator with lock, add the power consumption for the lock.

Weight

Product Weight

Series		LEY25S□ (Motor mounting position: Top mounting)									LEY32S□ (Motor mounting position: Top mounting)										
Stroke [mm]		30	50	100	150	200	250	300	350	400	30	50	100	150	200	250	300	350	400	450	500
Motor type	Incremental encoder	1.31	1.38	1.55	1.81	1.99	2.16	2.34	2.51	2.69	2.42	2.53	2.82	3.29	3.57	3.85	4.14	4.42	4.70	4.98	5.26
	Absolute encoder	1.37	1.44	1.61	1.87	2.05	2.22	2.40	2.57	2.75	2.36	2.47	2.76	3.23	3.51	3.79	4.08	4.36	4.64	4.92	5.20
Series		LEY25DS□ (Motor mounting position: In-line)									LEY32DS□ (Motor mounting position: In-line)										
Stroke [mm]		30	50	100	150	200	250	300	350	400	30	50	100	150	200	250	300	350	400	450	500
Motor type	Incremental encoder	1.34	1.41	1.58	1.84	2.02	2.19	2.37	2.54	2.72	2.44	2.55	2.84	3.31	3.59	3.87	4.16	4.44	4.72	5.00	5.28
	Absolute encoder	1.40	1.47	1.64	1.90	2.08	2.25	2.43	2.60	2.78	2.38	2.49	2.78	3.25	3.53	3.81	4.10	4.38	4.66	4.94	5.22

Additional Weight

[kg]

Size		25	32
Lock	Incremental encoder	0.20	0.40
	Absolute encoder	0.30	0.66
Rod end male thread	Male thread	0.03	0.03
	Nut	0.02	0.02
Foot (2 sets including mounting bolt)		0.08	0.14
Rod flange (including mounting bolt)		0.17	0.20
Head flange (including mounting bolt)			

Construction

Motor top mounting type: **LEY²⁵₃₂**

In-line motor type: **LEY²⁵₃₂D**

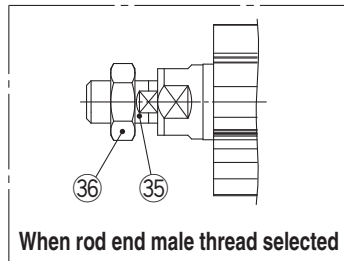
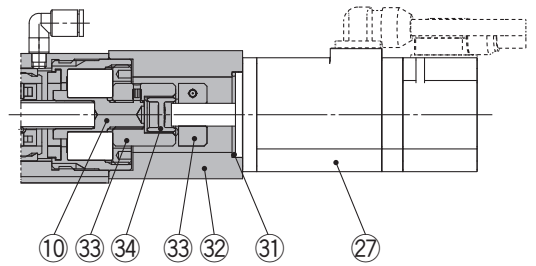
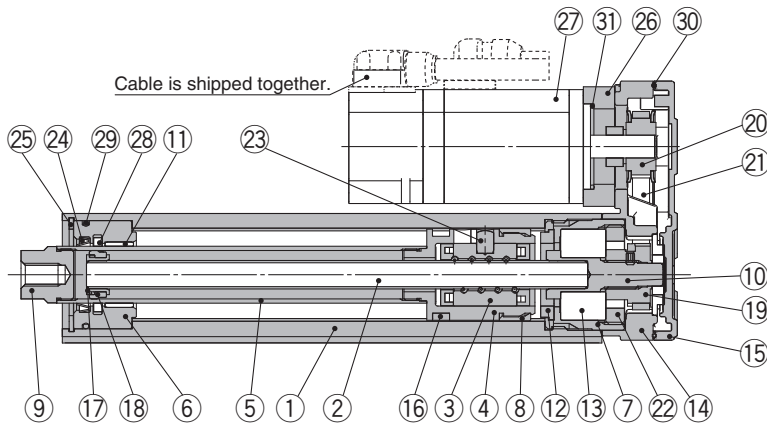

Component Parts

No.	Description	Material	Note
1	Body	Aluminium alloy	Anodised
2	Ball screw (shaft)	Alloy steel	
3	Ball screw nut	Resin/Alloy steel	
4	Piston	Aluminium alloy	
5	Piston rod	Stainless steel	Hard chrome Anodised
6	Rod cover	Aluminium alloy	
7	Housing	Aluminium alloy	
8	Rotation stopper	POM	
9	Socket	Free cutting carbon steel	Nickel plated
10	Connected shaft	Free cutting carbon steel	Nickel plated
11	Bushing	Lead bronze cast	
12	Bumper	Urethane	
13	Bearing	—	
14	Return box	Aluminium die-cast	Coating
15	Return plate	Aluminium die-cast	Coating
16	Magnet	—	
17	Wear ring holder	Stainless steel	Stroke 101 mm or more
18	Wear ring	POM	Stroke 101 mm or more

No.	Description	Material	Note
19	Screw shaft pulley	Aluminium alloy	
20	Motor pulley	Aluminium alloy	
21	Belt	—	
22	Bearing stopper	Aluminium alloy	
23	Parallel pin	Stainless steel	
24	Scraper	Nylon	
25	Retaining ring	Steel for spring	Nickel plated
26	Motor adapter	Aluminium alloy	Coating
27	Motor	—	
28	Lub-retainer	Felt	
29	O-ring	NBR	
30	Gasket	NBR	
31	O-ring	NBR	
32	Motor block	Aluminium alloy	Coating
33	Hub	Aluminium alloy	
34	Spider	Urethane	
35	Socket (Male thread)	Free cutting carbon steel	Nickel plated
36	Nut	Alloy steel	Zinc chromated

Replacement Parts (Top mounting only)/Belt

No.	Size	Order no.
21	25	LE-D-2-2
	32	LE-D-2-4

Replacement Parts/Grease Pack

Applied portion	Order no.
Piston rod	GR-S-010 (10 g)
	GR-S-020 (20 g)

* Apply grease on the piston rod periodically.
Grease should be applied at 1 million cycles or 200 km, whichever comes sooner.

Model Selection

LEY

LEYG

LECA6
LECP6

LEC-G

LECP1

LECPA

JXC□1

JXC7/3/3/3/2/3/3

LEY

LEYG

LECS□

LECS-T

LECY□

Specific Product Precautions

Series LEY-X5

AC Servo Motor

Dust/Drip proof (IP65 equivalent)

Dimensions

Motor top mounting type: LEY₃₂²⁵

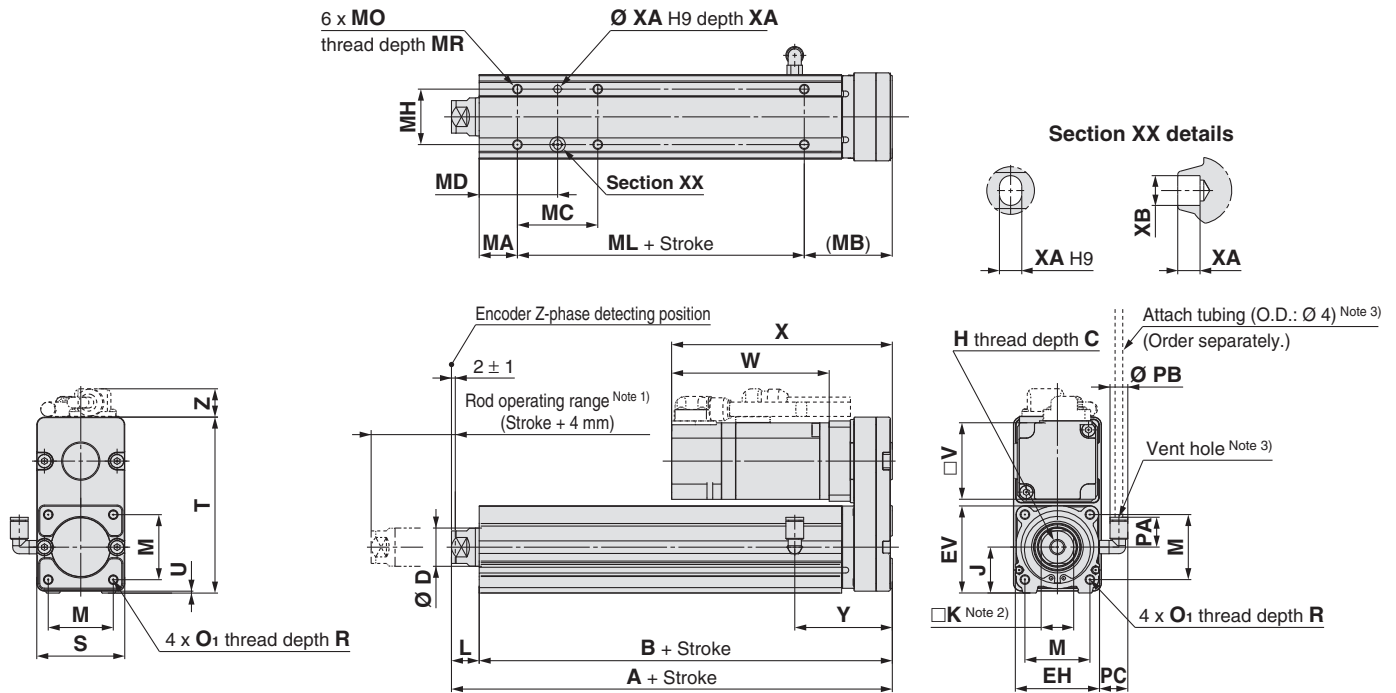

[mm]

Size	Stroke range [mm]	A	B	C	D	EH	EV	H	J	K	L	M	O ₁	R	PA	PB	V
25	15 to 100	130.5	116	13	20	44	45.5	M8 x 1.25	24	17	14.5	34	M5 x 0.8	8	15.4	8.2	40
	101 to 400	155.5	141														
32	20 to 100	148.5	130	13	25	51	56.5	M8 x 1.25	31	22	18.5	40	M6 x 1.0	10	15.4	8.2	60
	101 to 500	178.5	160														

Size	Stroke range [mm]	S	T	U	PC	Incremental encoder						Absolute encoder						Y
						Without lock			With lock			Without lock			With lock			
						W	X	Z	W	X	Z	W	X	Z	W	X	Z	
25	15 to 100	46	92	1	15.4	87	120	14.1	123.9	156.9	15.8	82.4	115.4	14.1	123.5	156.5	15.8	51
	101 to 400					87	120	14.1	123.9	156.9	15.8	82.4	115.4	14.1	123.5	156.5	15.8	
32	20 to 100	60	118	1	15.9	88.2	128.2	17.1	116.8	156.8	17.1	76.6	116.6	17.1	116.1	156.1	17.1	61
	101 to 500					88.2	128.2	17.1	116.8	156.8	17.1	76.6	116.6	17.1	116.1	156.1	17.1	

Body Bottom Tapped

[mm]

Size	Stroke range [mm]	MA	MB	MC	MD	MH	ML	MO	MR	XA	XB
25	15 to 39	20	46	24	32	29	50	M5 x 0.8	6.5	4	5
	40 to 100			42	41						
	101 to 124			59	49.5						
	125 to 200			76	58						
	201 to 400			76	58						
32	20 to 39	25	55	22	36	30	50	M6 x 1	8.5	5	6
	40 to 100			36	43						
	101 to 124			53	51.5						
	125 to 200			53	51.5						
	201 to 500			70	60						

Note 1) Range within which the rod can move. Make sure a workpiece mounted on the rod does not interfere with the workpieces and facilities around the rod.

Note 2) The direction of rod end width across flats (□K) differs depending on the products.

Note 3) The vent hole is the port for releasing to atmosphere. Do not apply pressure to this hole.

Attach tubing to the vent hole and place the end of the tubing so it is not exposed to dust or water.

For the rod end male thread, refer to page 138. For the mounting bracket dimensions, refer to page 25.

Dimensions

In-line motor type: LEY²⁵₃₂D

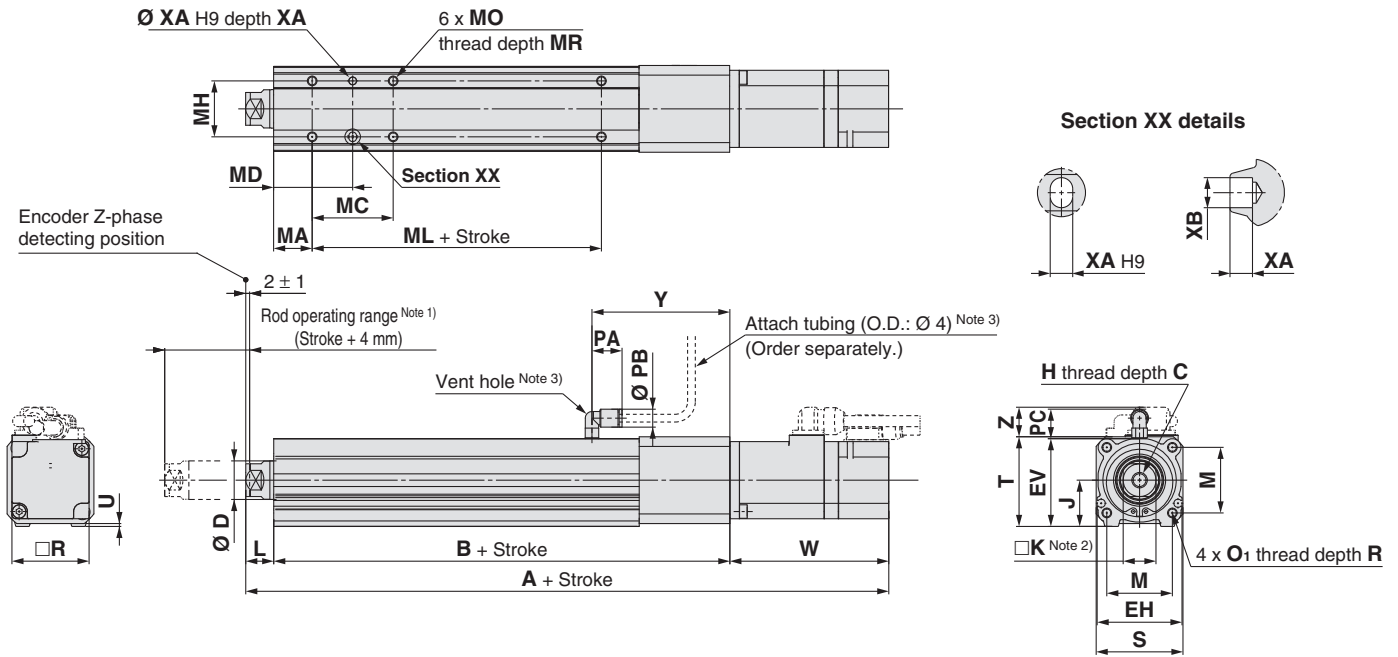

Size	Stroke range [mm]	Incremental encoder						Absolute encoder						B	C	D	EH	EV
		Without lock			With lock			Without lock			With lock							
		A	W	Z	A	W	Z	A	W	Z	A	W	Z					
25	15 to 100	238	87	14.6	274.9	123.9	16.3	233.4	82.4	14.6	274.5	123.5	16.3	136.5	13	20	44	45.5
	101 to 400	263			299.9			258.4			299.5			161.5				
32	20 to 100	262.7	88.2	17.1	291.3	116.8	17.1	251.1	76.6	17.1	290.6	116.1	17.1	156	13	25	51	56.5
	101 to 500	292.7			321.3			281.1			320.6			186				

Size	Stroke range [mm]	H	J	K	L	M	O ₁	R	PA	PB	V	S	T	U	PC	Y
25	15 to 100	M8 x 1.25	24	17	14.5	34	M5 x 0.8	8	15.4	8.2	40	45	46.5	1.5	15.9	71.5
	101 to 400															
32	20 to 100	M8 x 1.25	31	22	18.5	40	M6 x 1.0	10	15.4	8.2	60	60	61	1	15.9	87
	101 to 500															

Body Bottom Tapped

[mm]

Size	Stroke range [mm]	MA	MC	MD	MH	ML	MO	MR	XA	XB
25	15 to 39	20	24	32	29	50	M5 x 0.8	6.5	4	5
	40 to 100		42	41						
	101 to 124		59	49.5						
	125 to 200		76	58						
	201 to 400		76	58						
32	20 to 39	25	22	36	30	50	M6 x 1	8.5	5	6
	40 to 100		36	43						
	101 to 124		53	51.5						
	125 to 200		70	60						
	201 to 500		70	60						

Note 1) Range within which the rod can move. Make sure a workpiece mounted on the rod does not interfere with the workpieces and facilities around the rod.

Note 2) The direction of rod end width across flats (□K) differs depending on the products.

Note 3) The vent hole is the port for releasing to atmosphere. Do not apply pressure to this hole.

Attach tubing to the vent hole and place the end of the tubing so it is not exposed to dust or water.

For the rod end male thread, refer to page 138. For the mounting bracket dimensions, refer to page 25.

Model Selection

LEY

LEYG

LECA6
LECP6

LEC-G

LECP1

LECPA

JXC□1

JXC7303/92/93

LEY

AC Servo Motor

LEYG

LECS□

LECS-T

LECY□

Specific Product Precautions

Electric Actuator/Rod Type

AC Servo Motor

Series 25A-LEY

RoHS

LEY25, 32 Size 25, 32

How to Order

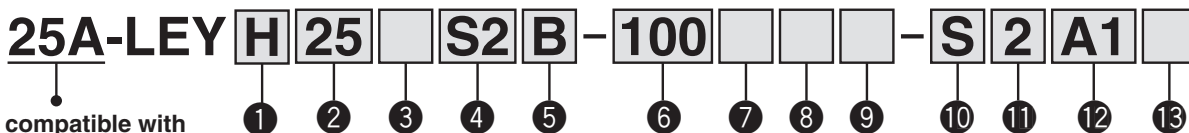

Series compatible with secondary batteries

1 Accuracy

—	Basic Type
H	High precision type

2 Size

25
32

3 Motor mounting position

—	Top mounting
R	Right side parallel
L	Left side parallel
D	In-line

5 Lead [mm]

Symbol	LEY25	LEY32*
A	12	16 (20)
B	6	8 (10)
C	3	4 (5)

* The values shown in () are the lead for size 32 top mounting, right/left side parallel types. (Equivalent lead which includes the pulley ratio [1.25:1])

6 Stroke [mm]

30	30
to	to
500	500

* Refer to the table below for details.

8 Rod end thread

—	Female rod end
M	Male rod end (1 rod end nut is included.)

4 Motor type*1

Symbol	Type	Output [W]	Actuator size	Compatible drivers*2
S2	AC servo motor (Incremental encoder)	100	25	LECSA□-S1
S3	AC servo motor (Incremental encoder)	200	32	LECSA□-S3
S6	AC servo motor (Absolute encoder)	100	25	LECSB□-S5 LECSC□-S5 LECSS□-S5
S7	AC servo motor (Absolute encoder)	200	32	LECSB□-S7 LECSC□-S7 LECSS□-S7

*1 For motor type S2 and S6, the compatible driver part number suffixes are S1 and S5 respectively.

*2 For details about the driver, refer to the website www.smc.eu.

7 Motor option

—	Without option
B	With lock*

* When "With lock" is selected for the top mounting and right/left side parallel types, the motor body will stick out of the end of the body for size 25 with strokes 30 or less. Check for interference with workpieces before selecting a model.

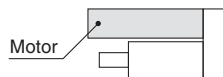

9 Mounting*1

Symbol	Type	Motor mounting position	
		Top/Parallel	In-line
—	Ends tapped (Standard)*2	●	●
L	Foot	●	—
F	Rod flange*2	●*4	●
G	Head flange*2	●*5	—
D	Double clevis*3	●	—

*1 Mounting bracket is shipped together, (but not assembled).

*2 For horizontal cantilever mounting with the rod flange, head flange and ends tapped, use the actuator within the following stroke range.

· LEY25: 200 or less · LEY32: 100 or less

*3 For mounting with the double clevis, use the actuator within the following stroke range.

· LEY25: 200 or less · LEY32: 200 or less

*4 Rod flange is not available for the LEY25 with stroke 30 and motor option "With lock".

*5 Head flange is not available for the LEY32.

Mounting Bracket Part No. for Series 25A-

Applicable size	Foot*1	Flange	Double clevis
25	25-LEY-L025	25-LEY-F025	25-LEY-D025
32	25-LEY-L032	25-LEY-F032	25-LEY-D032
Surface treatment	RAYDENT®	RAYDENT®	Coating (Size 16: Electroless nickel plating)

*1 When ordering foot brackets, order 2 pieces per actuator.

*2 Parts belonging to each bracket are as follows.

Foot, Flange: Body mounting bolt, Double clevis: Clevis pin, Type C retaining ring for axis, Body mounting bolt

* Applicable stroke table

Model	Stroke [mm]	Standard										Manufacturable stroke range [mm]	
		30	50	100	150	200	250	300	350	400	450		500
LEY25		●	●	●	●	●	●	●	●	●	—	—	15 to 400
LEY32		●	●	●	●	●	●	●	●	●	●	●	20 to 500

* Consult with SMC for non-standard strokes as they are produced as special orders.

For details about auto switches, refer to "Series Compatible with Secondary Batteries" .

Applicable auto switches

D-M9N(V)-900, D-M9P(V)-900, D-M9B(V)-900
D-M9NW(V)-900, D-M9PW(V)-900, D-M9BW(V)-900

Electric Actuator/Rod Type **Series 25A-LEY**

AC Servo Motor

Size **25, 32**

Secondary Battery Compatible

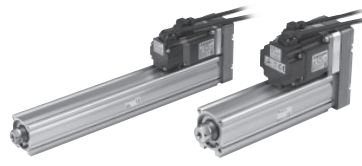

Motor mounting position:
Top/Parallel



Motor mounting position:
In-line

10 Cable type*

—	Without cable
S	Standard cable
R	Robotic cable (Flexible cable)

- * The motor and encoder cables are included. (The lock cable is also included when the motor with lock option is selected.)
- * Standard cable entry direction is
 - Top/Parallel: (A) Axis side
 - In-line: (B) Counter axis side

11 Cable length* [m]

—	Without cable
2	2
5	5
A	10

- * The length of the encoder, motor and lock cables are the same.

12 Driver type*

	Compatible drivers	Power supply voltage [V]
—	Without driver	—
A1	LECSA1-S□	100 to 120
A2	LECSA2-S□	200 to 230
B1	LECSB1-S□	100 to 120
B2	LECSB2-S□	200 to 230
C1	LECSC1-S□	100 to 120
C2	LECSC2-S□	200 to 230
S1	LECSS1-S□	100 to 120
S2	LECSS2-S□	200 to 230

- * When the driver type is selected, the cable is included. Select cable type and cable length.
Example)
S2S2: Standard cable (2 m) + Driver (LECSS2)
S2 : Standard cable (2 m)
— : Without cable and driver





13 I/O Cable length [m]*

—	Without cable
H	Without cable (Connector only)
1	1.5

- * When "Without driver" is selected for driver type, only "—: Without cable" can be selected. Refer to the **WEB LEY** if I/O cable is required.

* Specifications and dimensions for the 25A-series are the same as standard products.

Compatible Drivers

Driver type	Pulse input type/ Positioning type	Pulse input type	CC-Link direct input type	SSCNET III type
				
Series	LECSA	LECSB	LECSC	LECSS
Number of point tables	Up to 7	—	Up to 255 (2 stations occupied)	—
Pulse input	○	○	—	—
Applicable network	—	—	CC-Link	SSCNET III
Control encoder	Incremental 17-bit encoder	Absolute 18-bit encoder	Absolute 18-bit encoder	Absolute 18-bit encoder
Communication function	USB communication	USB communication, RS422 communication	USB communication, RS422 communication	USB communication
Power supply voltage [V]	100 to 120 VAC (50 / 60 Hz) 200 to 230 VAC (50 / 60 Hz)			

- * Copper and zinc materials are used for the motors, cables, controllers/drivers.

Model Selection



Moment Load Graph

Selection conditions

Mounting position	Vertical		Horizontal	
Max. speed [mm/s]	"Speed-Vertical Work Load Graph"		200 or less	Over 200
Graph (Sliding bearing type)	①, ②		⑤, ⑥*	⑦, ⑧
Graph (Ball bushing bearing type)	③, ④		⑨, ⑩	⑪, ⑫

* For the sliding bearing type, the speed is restricted with a horizontal/moment load.

Vertical Mounting, Sliding Bearing

① 70 stroke or less

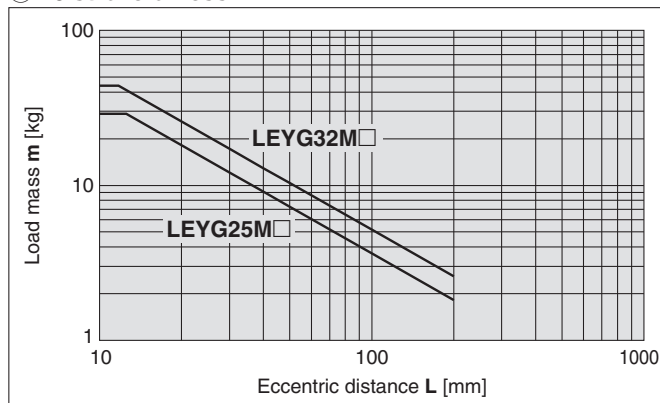

* The limit of vertical load mass varies depending on "lead" and "speed".
Check "Speed-Vertical Work Load Graph" on page 159.

② Over 75 stroke

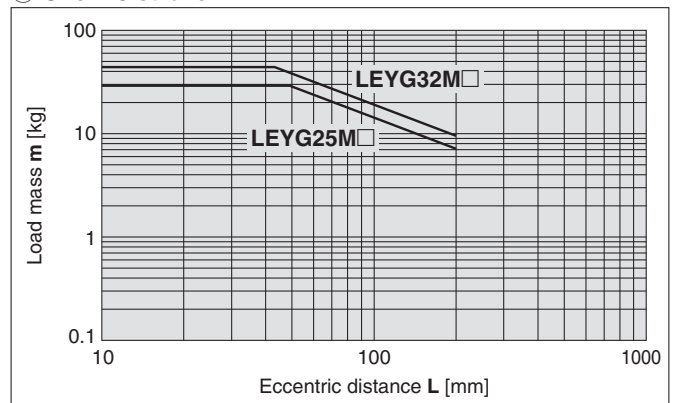

Vertical Mounting, Ball Bushing Bearing

③ 35 stroke or less

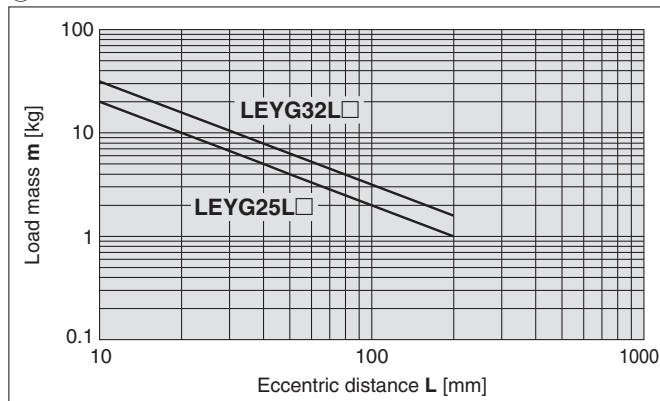

* The limit of vertical load mass varies depending on "lead" and "speed".
Check "Speed-Vertical Work Load Graph" on page 159.

④ Over 40 stroke

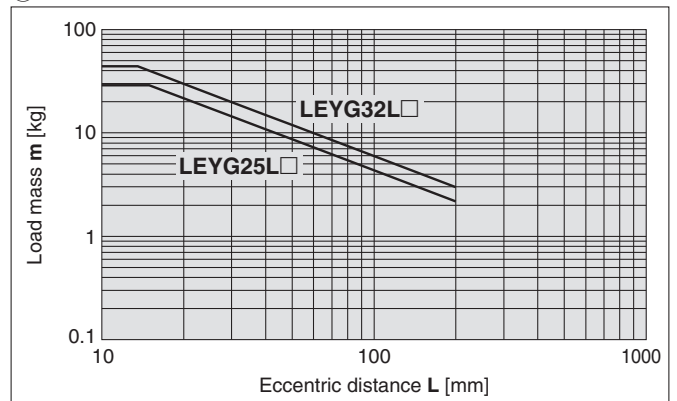

Moment Load Graph

Horizontal Mounting, Sliding Bearing

⑤ L = 50 mm Max. speed = 200 mm/s or less

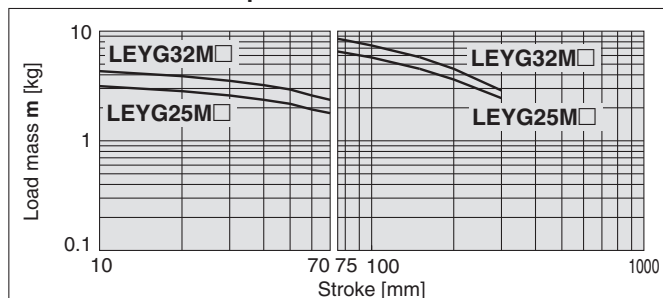

⑥ L = 100 mm Max. speed = 200 mm/s or less

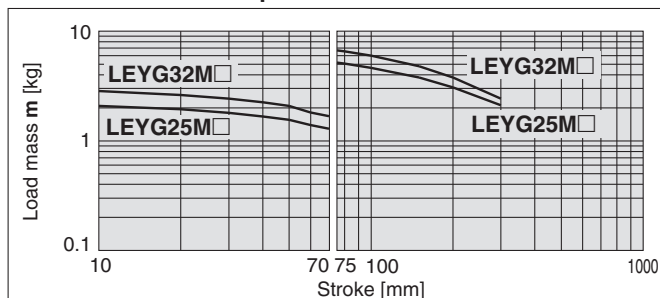

⑦ L = 50 mm Max. speed = Over 200 mm/s

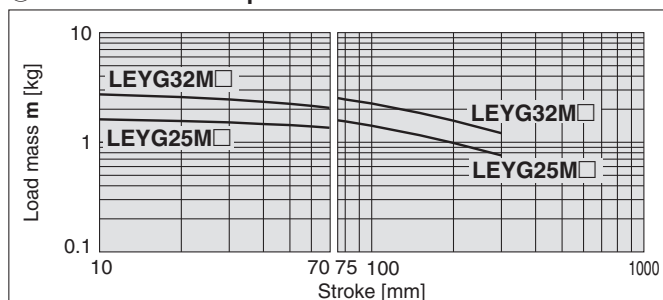

⑧ L = 100 mm Max. speed = Over 200 mm/s

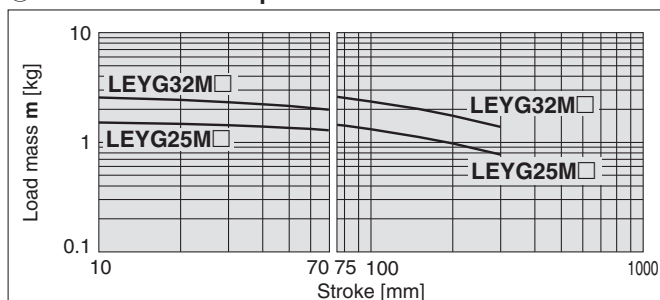

Horizontal Mounting, Ball Bushing Bearing

⑨ L = 50 mm Max. speed = 200 mm/s or less

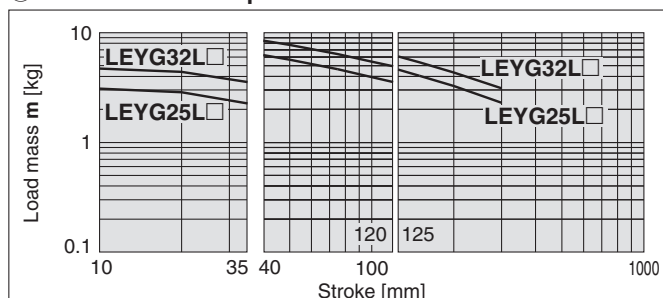

⑩ L = 100 mm Max. speed = 200 mm/s or less

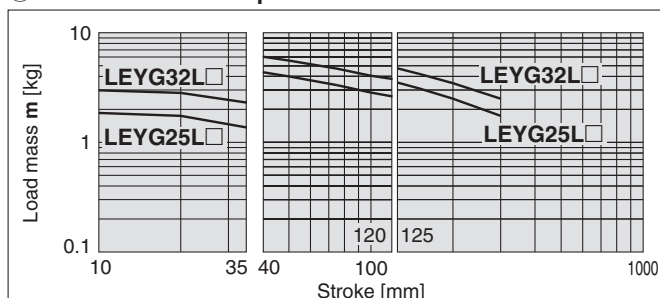

⑪ L = 50 mm Max. speed = Over 200 mm/s

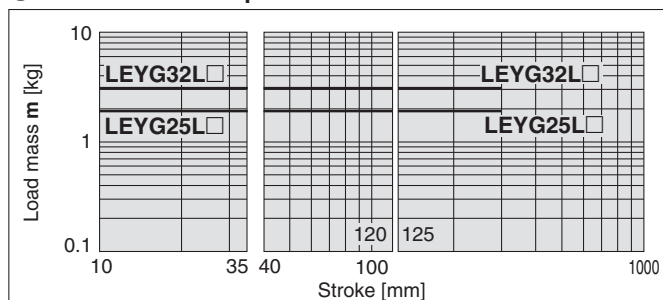

⑫ L = 100 mm Max. speed = Over 200 mm/s

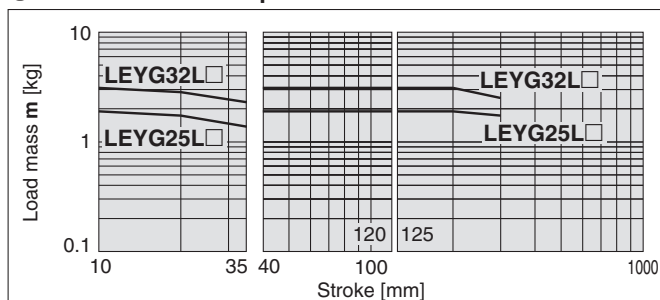

Operating Range when Used as Stopper

LEYG□M (Sliding bearing)

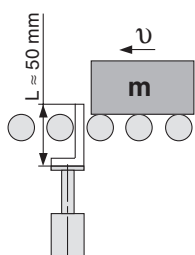

⚠ Caution

Handling Precautions

- Note 1) When used as a stopper, select a model with 30 stroke or less.
- Note 2) LEYG□L (ball bushing bearing) cannot be used as a stopper.
- Note 3) Workpiece collision in series with guide rod cannot be permitted (Fig. a).
- Note 4) The body should not be mounted on the end. It must be mounted on the top or bottom (Fig. b).

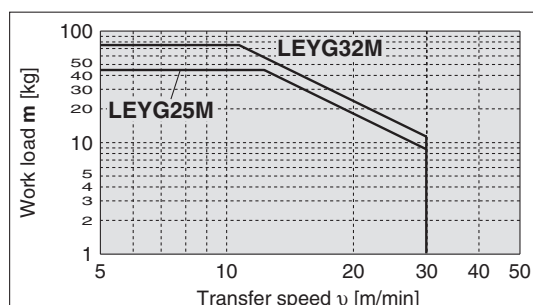
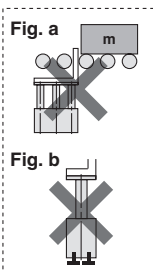

- LEY
- LEYG
- LECA6
- LECP6
- LEC-G
- LECP1
- LECPA

- JXC□1
- JXC7303/92/93

- LEY
- LEYG

- LECS
- LECS-T

- LECY
- Specific Product Precautions

Speed–Vertical Work Load Graph/Required Conditions for “Regeneration Option”

LEYG25 (Motor mounting position: Top mounting/In-line)

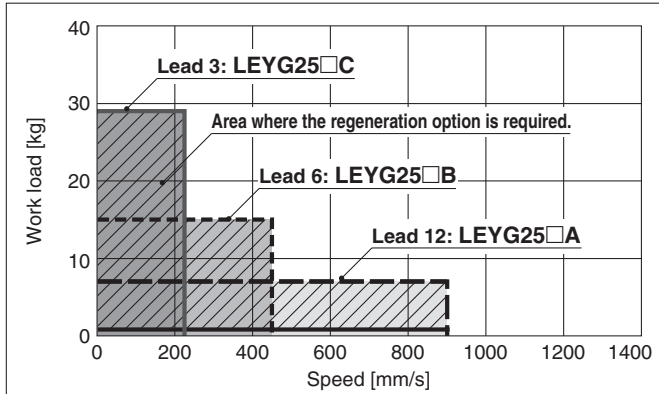

Required conditions for “Regeneration option”

* Regeneration option is required when using product above regeneration line in graph. (Order separately.)

“Regeneration Option” Models

Size	Model
LEYG25	LEC-MR-RB-032
LEYG32	LEC-MR-RB-032

LEYG32 (Motor mounting position: Top mounting)

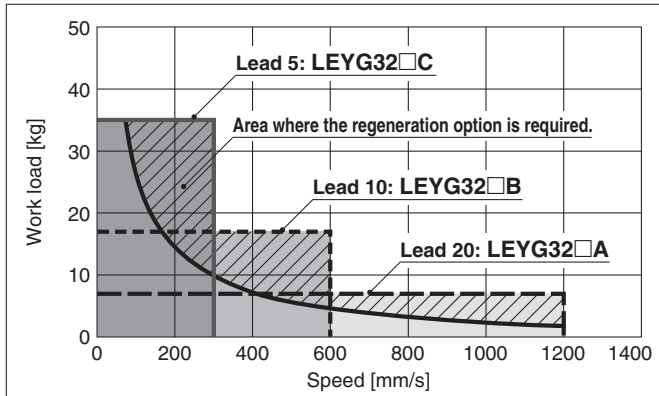

LEYG32D (Motor mounting position: In-line)

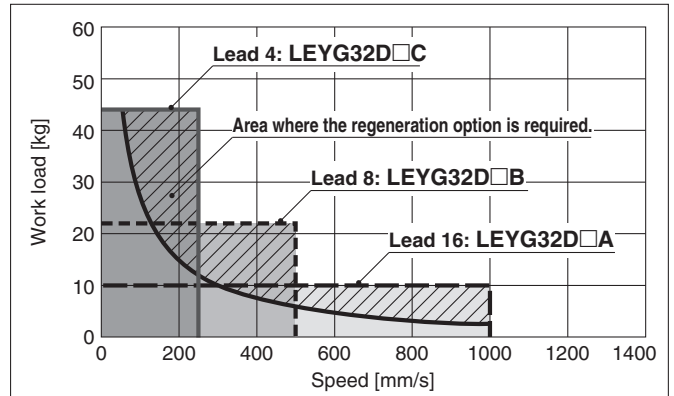

Speed–Horizontal Work Load Graph/Required Conditions for “Regeneration Option”

LEYG25 (Motor mounting position: Top mounting/In-line)

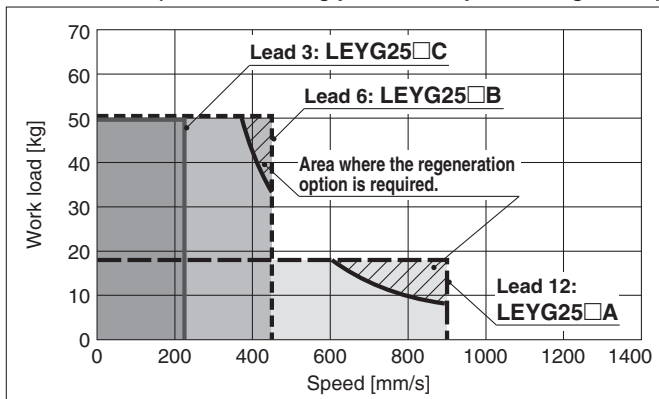

Required conditions for “Regeneration option”

* Regeneration option is required when using product above regeneration line in graph. (Order separately.)

“Regeneration Option” Models

Size	Model
LEYG25	LEC-MR-RB-032
LEYG32	LEC-MR-RB-032

LEYG32 (Motor mounting position: Top mounting)

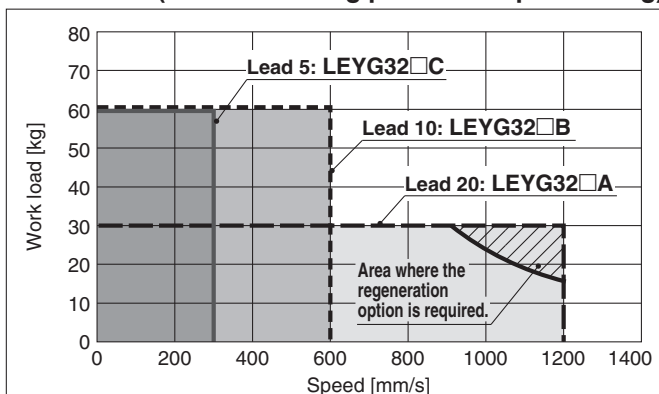

LEYG32D (Motor mounting position: In-line)

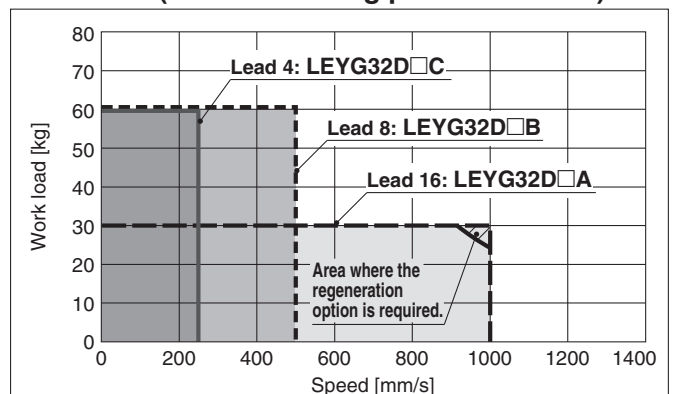

Force Conversion Graph

LEYG25□ (Motor mounting position: Top mounting/In-line)

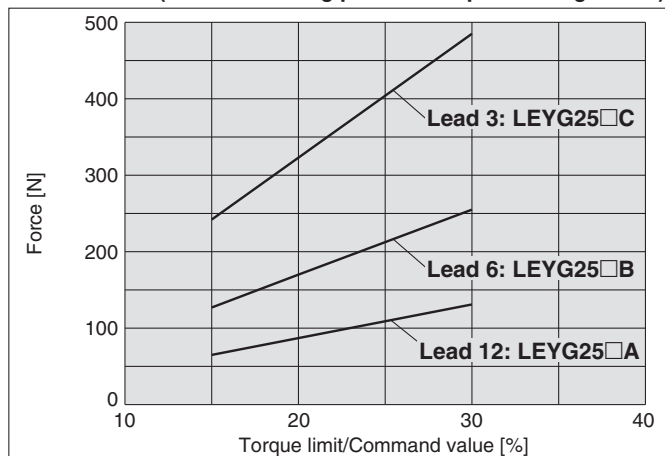

Torque limit/Command value [%]	Duty ratio [%]	Continuous pushing time [minute]
25 or less	100	—
30	60	1.5

LEYG32□ (Motor mounting position: Top mounting)

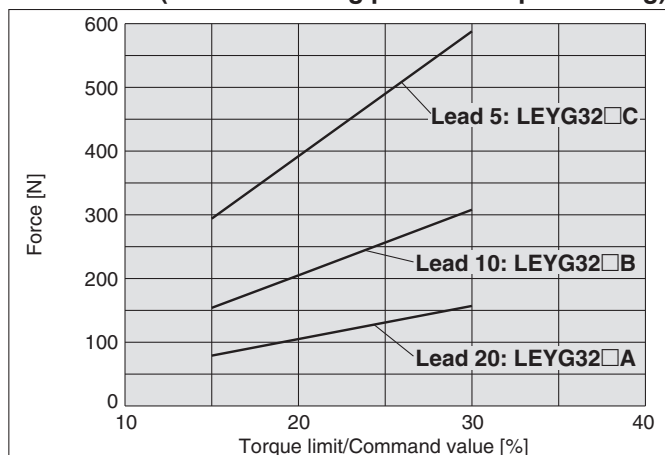

Torque limit/Command value [%]	Duty ratio [%]	Continuous pushing time [minute]
25 or less	100	—
30	60	1.5

LEYG32D (Motor mounting position: In-line)

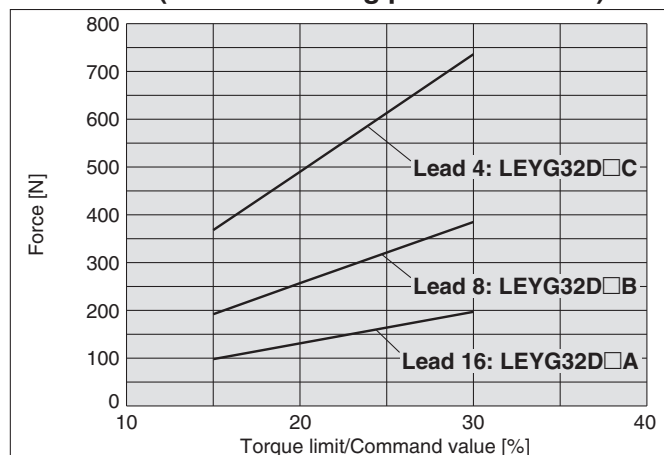

Torque limit/Command value [%]	Duty ratio [%]	Continuous pushing time [minute]
25 or less	100	—
30	60	1.5

Servo Motor (24 VDC) (Step Motor (Servo/24 VDC))
LEYG
LEYG

LECA6
LECP6

LEC-G

LECP1

LECPA

JXC□1

JXC7303/92/93

LEYG

AC Servo Motor
LEYG

LECS□

LECS-T

LECY□

LECY□

Specific Product Precautions

Electric Actuator/ Guide Rod Type

Series LEYG LEYG25, 32



MECHATROLINK Compatible ▶ Page 200

How to Order

LEY **H** **G** **25** **M** **S2** **B** - **100** - **S** **2** **A1**

① ② ③ ④ ⑤ ⑥ ⑦ ⑧ ⑨ ⑩ ⑪ ⑫ ⑬

① Accuracy

—	Basic type
H	High precision type

② Size

25
32

③ Bearing type

M	Sliding bearing
L	Ball bushing bearing

④ Motor mounting position

—	Top mounting
D	In-line

⑤ Motor type*¹

Symbol	Type	Output [W]	Actuator size	Compatible driver* ³	UL-compliant
S2	AC servo motor (Incremental encoder)	100	25	LECSA□-S1	—
S3	AC servo motor (Incremental encoder)	200	32	LECSA□-S3	—
S6	AC servo motor (Absolute encoder)	100	25	LECSB□-S5 LECSC□-S5 LECSS□-S5	—
S7	AC servo motor (Absolute encoder)	200	32	LECSB□-S7 LECSC□-S7 LECSS□-S7	—
T6 * ²	AC servo motor (Absolute encoder)	100	25	LECSS2-T5	●
T7		200	32	LECSS2-T7	●

*¹ For motor type S2 and S6, the compatible driver part number suffixes are S1 and S5 respectively.

*² For motor type T6, the compatible driver part number suffix is T5.

*³ For details about the driver, refer to page 173.

⑥ Lead [mm]

Symbol	LEYG25	LEYG32*
A	12	16 (20)
B	6	8 (10)
C	3	4 (5)

* The values shown in () are the lead for size 32 top mounting types. (Equivalent lead which includes the pulley ratio [1.25:1])

⑦ Stroke [mm]

30	30
to	to
300	300

* Refer to the applicable stroke table.

* There is a limit for mounting size 32 top mounting type and 50 mm stroke or less. Refer to the dimensions.

⑧ Motor option

—	Without option
B	With lock

⑨ Guide option

—	Without option
F	With grease retaining function

* Only available for size 25 and 32 sliding bearings. (Refer to "Construction" on page 165.)

⑩ Cable type*

—	Without cable
S	Standard cable
R	Robotic cable (Flexible cable)

* The motor and encoder cables are included. (The lock cable is also included when the motor with lock option is selected.)

* Standard cable entry direction is

- Top mounting: (A) Axis side
- In-line: (B) Counter axis side

(Refer to page 185 for details.)

⑪ Cable length* [m]

—	Without cable
2	2
5	5
A	10

* The length of the encoder, motor and lock cables are the same.

* Applicable stroke table

●: Standard

Model	Stroke [mm]	30	50	100	150	200	250	300	Manufacturable stroke range
LEYG25		●	●	●	●	●	●	●	15 to 300
LEYG32		●	●	●	●	●	●	●	20 to 300

Note) Please consult with SMC for non-standard strokes as they are produced as special orders.

For auto switches, refer to pages 27 and 28.

Electric Actuator/Guide Rod Type **Series LEYG**

AC Servo Motor

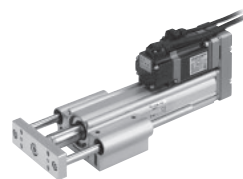

Motor mounting position: Top mounting

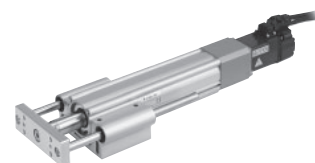

Motor mounting position: In-line

12 Driver type*

	Compatible driver	Power supply voltage [V]	UL-compliant
—	Without driver	—	—
A1	LECSA1-S□	100 to 120	—
A2	LECSA2-S□	200 to 230	—
B1	LECSB1-S□	100 to 120	—
B2	LECSB2-S□	200 to 230	—
C1	LECSC1-S□	100 to 120	—
C2	LECSC2-S□	200 to 230	—
S1	LECSS1-S□	100 to 120	—
S2	LECSS2-S□	200 to 230	—
	LECSS2-T□	200 to 240	●

* When the driver type is selected, the cable is included. Select cable type and cable length.

Example)

S2S2: Standard cable (2 m) + Driver (LECSS2)

S2 : Standard cable (2 m)

— : Without cable and driver

13 I/O cable length [m]*

	Without cable
H	Without cable (Connector only)
1	1.5

* When "Without driver" is selected for driver type, only "—: Without cable" can be selected. Refer to page 186 if I/O cable is required. (Options are shown on page 186.)

Use of auto switches for the guide rod type LEYG series

- Insert the auto switch from the front side with rod (plate) sticking out.
- For the parts hidden behind the guide attachment (Rod stick out side), the auto switch cannot be fixed.
- Please consult with SMC when using auto switch on the rod stick out side, as it is produced as a special order.

Compatible Driver

Driver type	Pulse input type /Positioning type	Pulse input type	CC-Link direct input type	SSCNET III type	SSCNET III/H Type
Series	LECSA	LECSB	LECSC	LECSS	LECSS-T
Number of point tables	Up to 7	—	Up to 255 (2 stations occupied)	—	—
Pulse input	○	○	—	—	—
Applicable network	—	—	CC-Link	SSCNET III	SSCNET III/H
Control encoder	Incremental 17-bit encoder	Absolute 18-bit encoder	Absolute 18-bit encoder	Absolute 18-bit encoder	Absolute 22-bit encoder
Communication function	USB communication	USB communication, RS422 communication	—	USB communication	USB communication
Power supply voltage [V]	100 to 120 VAC (50/60 Hz) 200 to 230 VAC (50/60 Hz)				200 to 240 VAC (50/60 Hz)
Reference page	Page 173				Page 189

Series LEYG

AC Servo Motor

Specifications

Model		LEYG25□S ₂ ² (Top mounting) LEYG25□DS ₂ ² (In-line)			LEYG32□S ₃ ³ (Top mounting)			LEYG32□DS ₃ ³ (In-line)			
Actuator specifications	Stroke [mm] ^{Note 1)}	30, 50, 100, 150, 200, 250, 300			30, 50, 100, 200, 250, 300			30, 50, 100, 200, 250, 300			
	Work load [kg]	Horizontal ^{Note 2)}	18	50	50	30	60	60	30	60	60
		Vertical	7	15	29	7	17	35	10	22	44
	Force [N] ^{Note 3)} (Set value: 15 to 30 %)	65 to 131	127 to 255	242 to 485	79 to 157	154 to 308	294 to 588	98 to 197	192 to 385	368 to 736	
	Max. speed [mm/s]	900			1200			1000			
	Pushing speed [mm/s ²] ^{Note 4)}	35 or less			30 or less			30 or less			
	Max. acceleration/deceleration [mm/s ²]	5000			5000						
	Positioning repeatability [mm]	Basic type				±0.02					
		High precision type				±0.01					
	Lost motion ^{Note 5)} [mm]	Basic type				0.1 or less					
		High precision type				0.05 or less					
	Lead [mm] (including pulley ratio)		12	6	3	20	10	5	16	8	4
	Impact/Vibration resistance [m/s ²] ^{Note 6)}		50/20			50/20					
	Actuation type		Ball screw + Belt [1:1]/Ball screw			Ball screw + Belt [1:1.25]			Ball screw		
	Guide type		Sliding bearing (LEYG□M), Ball bushing bearing (LEYG□L)								
Operating temperature range [°C]		5 to 40			5 to 40						
Operating humidity range [%RH]		90 or less (No condensation)			90 or less (No condensation)						
Regeneration option ^{Note 7)}		May be required depending on speed and work load (refer to page 159)									
Motor output/Size		100 W/□40			200 W/□60						
Motor type		AC servo motor (100/200 VAC)			AC servo motor (100/200 VAC)						
Encoder		Motor type S2, S3: Incremental 17-bit encoder (Resolution: 131072 p/rev) Motor type S6, S7: Absolute 18-bit encoder (Resolution: 262144 p/rev)									
Power consumption [W] ^{Note 8)}	Horizontal	45			65			65			
	Vertical	145			175			175			
Standby power consumption when operating [W] ^{Note 9)}	Horizontal	2			2			2			
	Vertical	8			8			8			
Max. instantaneous power consumption [W] ^{Note 10)}		445			724			724			
Type ^{Note 11)}		Non-magnetizing lock			Non-magnetizing lock						
Holding force [N]		131	255	485	157	308	588	197	385	736	
Power consumption at 20 °C [W] ^{Note 12)}		6.3			7.9			7.9			
Rated Voltage [V]		24 VDC									

Note 1) Please consult with SMC for non-standard strokes as they are produced as special orders.

Note 2) The maximum value of the horizontal work load. An external guide is necessary to support the load. The actual work load changes according to the condition of the external guide. Please confirm using actual device.

Note 3) The force setting range (set values for the driver) for the force control with the torque control mode. Set it with reference to "Force Conversion Graph" on page 158. When the control equivalent to the pushing operation of the controller LECP series is performed, select the LECS driver and combine it with the Simple Motion (manufactured by Mitsubishi Electric Corporation) which has a pushing operation function.

Note 4) The allowable collision speed for collision with the workpiece with the torque control mode.

Note 5) A reference value for correcting an error in reciprocal operation.

Note 6) Impact resistance: No malfunction occurred when the actuator was tested with a drop tester in both an axial direction and a perpendicular direction to the lead screw. (Test was performed with the actuator in the initial state.)

Vibration resistance: No malfunction occurred in a test ranging between 45 to 2000 Hz. Test was performed in both an axial direction and a perpendicular direction to the lead screw. (Test was performed with the actuator in the initial state.)

Note 7) The work load conditions which require "Regeneration option" when operating at the maximum speed (Duty ratio: 100 %). Order the regeneration option separately. For details and order numbers, refer to "Required Conditions for Regeneration Option" on page 157.

Note 8) The power consumption (including the driver) is for when the actuator is operating.

Note 9) The standby power consumption when operating (including the driver) is for when the actuator is stopped in the set position during operation.

Note 10) The maximum instantaneous power consumption (including the driver) is for when the actuator is operating.

Note 11) Only when motor option "With lock" is selected.

Note 12) For an actuator with lock, add the power consumption for the lock.

Weight

Weight: Top Mounting Type

Series		LEYG25M							LEYG32M						
Stroke [mm]		30	50	100	150	200	250	300	30	50	100	150	200	250	300
Motor type	Incremental encoder	1.80	1.99	2.31	2.73	3.07	3.41	3.67	3.24	3.50	4.05	4.80	5.35	5.83	6.28
	Absolute encoder	1.86	2.05	2.37	2.79	3.13	3.47	3.73	3.18	3.44	3.99	4.74	5.29	5.77	6.22

Weight: In-line Motor Type

Series		LEYG25LD							LEYG32LD						
Stroke [mm]		30	50	100	150	200	250	300	30	50	100	150	200	250	300
Motor type	Incremental encoder	1.83	2.02	2.34	2.76	3.10	3.44	3.70	3.26	3.52	4.07	4.82	5.37	5.85	6.30
	Absolute encoder	1.89	2.08	2.40	2.82	3.16	3.50	3.76	3.20	3.46	4.01	4.76	5.31	5.79	6.24

Additional Weight

Size		25	32
Lock	Incremental encoder	0.20	0.40
	Absolute encoder	0.30	0.66

Model Selection

LEYG

LEYG

LECA6
LECP6

LEC-G

LECP1

LECPA

JXC□1

JXC7□□□□□□□□

LEYG

LECS□

LECS-T

LECY□

Specific Product Precautions

Series LEYG

AC Servo Motor

Construction

Motor mounting position: Top mounting type

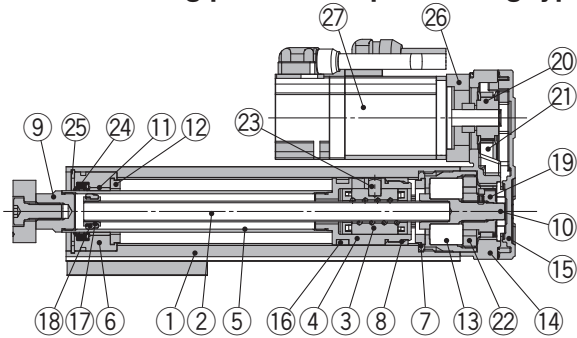

Motor mounting position: In-line type

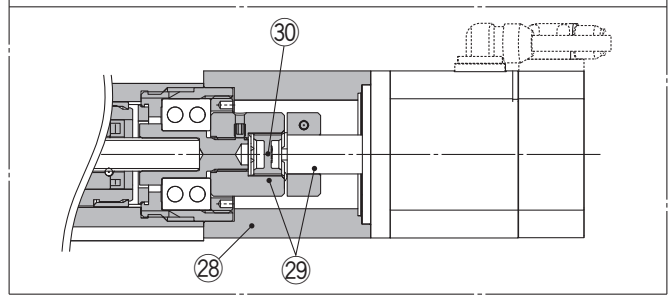

LEYG□M

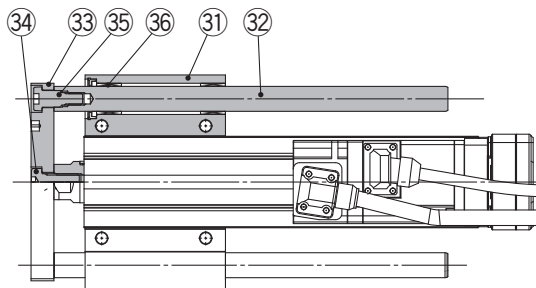

LEYG25/32: 50st or less



When grease retaining function selected

LEYG25/32: 50st or less

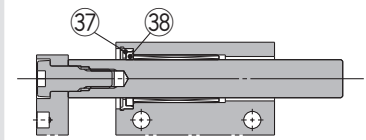

LEYG25/32: Over 50st



LEYG25/32: Over 50st

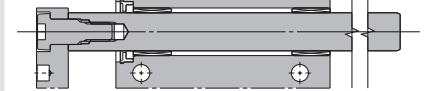

LEYG□L

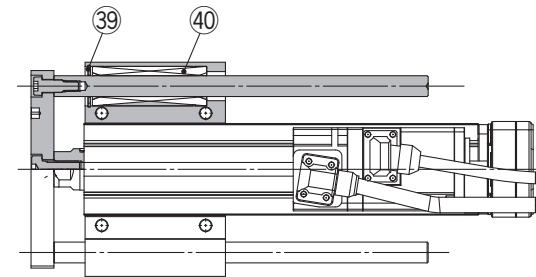

LEYG25/32L: 100st or less

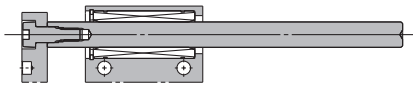

LEYG25/32: Over 100st

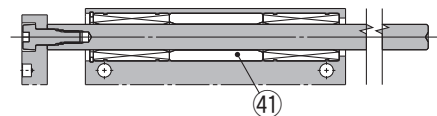

Component Parts

No.	Description	Material	Note
1	Body	Aluminium alloy	Anodised
2	Ball screw shaft	Alloy steel	
3	Ball screw nut	—	
4	Piston	Aluminium alloy	
5	Piston rod	Stainless steel	Hard chrome Anodised
6	Rod cover	Aluminium alloy	
7	Housing	Aluminium alloy	
8	Rotation stopper	POM	
9	Socket	Free cutting carbon steel	Nickel plated
10	Connected shaft	Free cutting carbon steel	Nickel plated
11	Bushing	Lead bronze cast	
12	Bumper	Urethane	
13	Bearing	—	
14	Return box	Aluminium die-cast	Coating
15	Return plate	Aluminium die-cast	Coating
16	Magnet	—	
17	Wear ring holder	Stainless steel	Stroke 101 mm or more
18	Wear ring	POM	Stroke 101 mm or more
19	Screw shaft pulley	Aluminium alloy	
20	Motor pulley	Aluminium alloy	
21	Belt	—	
22	Bearing stopper	Aluminium alloy	
23	Parallel pin	Stainless steel	
24	Seal	NBR	
25	Retaining ring	Steel for spring	Phosphate coated
26	Motor adapter	Aluminium alloy	Coating
27	Motor	—	

No.	Description	Material	Note
28	Motor block	Aluminium alloy	Coating
29	Hub	Aluminium alloy	
30	Spider	Urethane	Spider
31	Guide attachment	Aluminium alloy	Anodised
32	Guide rod	Carbon steel	
33	Plate	Aluminium alloy	Anodised
34	Plate mounting bolt	Carbon steel	Nickel plated
35	Guide bolt	Carbon steel	Nickel plated
36	Sliding bearing	—	
37	Felt	Felt	
38	Holder	Resin	
39	Retaining ring	Steel for spring	Phosphate coated
40	Ball bushing	—	
41	Spacer	Aluminium alloy	Chromated

Support Block

Size	Order no.
25	LEYG-S025
32	LEYG-S032

* Two body mounting bolts are included with the support block.

Replacement Parts /Belt

Size	Order no.
25	LE-D-2-2
32	LE-D-2-4

Replacement Parts/Grease Pack

Applied portion	Order no.
Piston rod	GR-S-010 (10 g)
Guide rod	GR-S-020 (20 g)

* Apply grease on the piston rod periodically. Grease should be applied at 1 million cycles or 200 km, whichever comes first.

Dimensions: Top Mounting

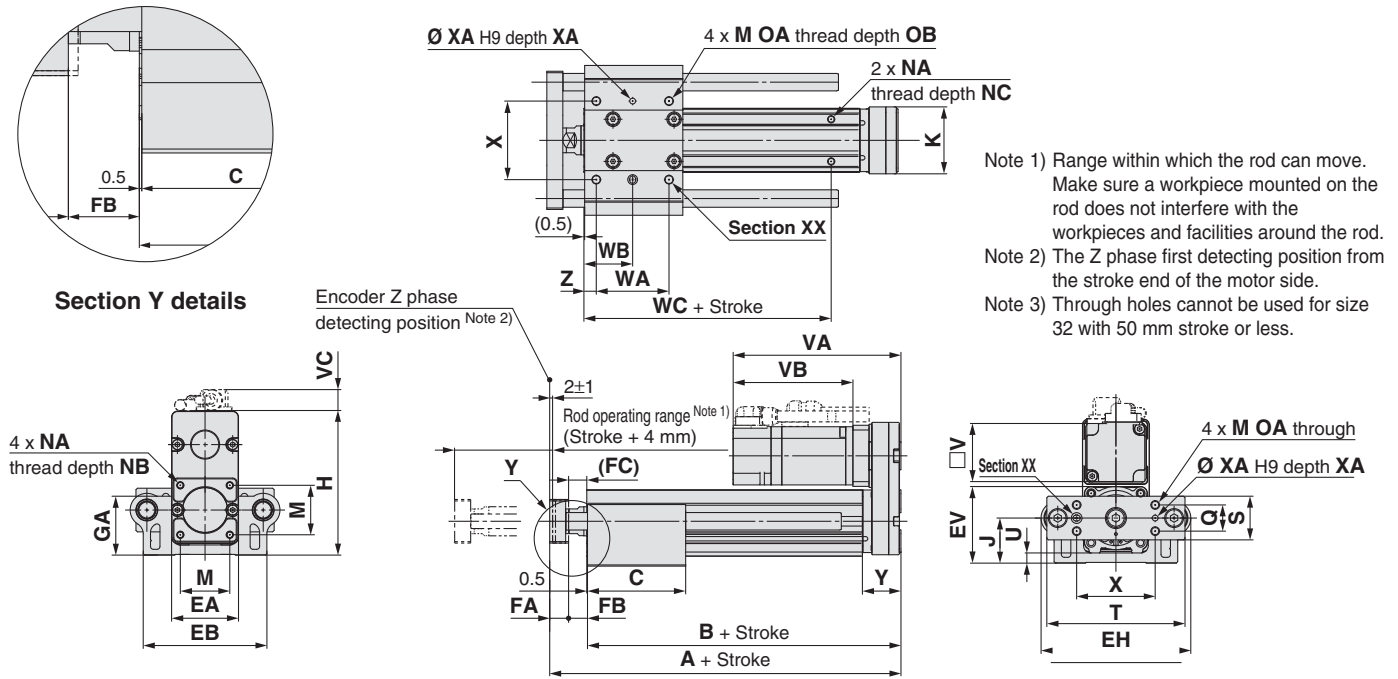

LEYG□L (Ball bushing bearing) [mm]

Size	Stroke range [mm]	L	DB
25	Up to 114	91	10
	115 to 190	115	
	191 to 300	133	
32	Up to 114	97.5	13
	115 to 190	116.5	
	191 to 300	34	

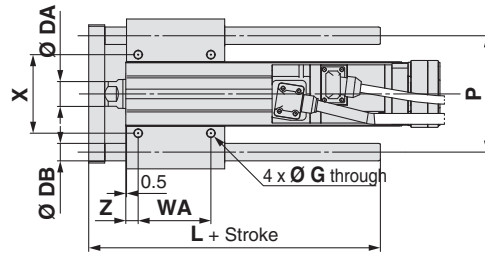

LEYG□M (Sliding bearing) [mm]

Size	Stroke range [mm]	L	DB
25	Up to 59	67.5	12
	60 to 185	100.5	
	186 to 300	138	
32	Up to 59	74	16
	60 to 185	107	
	186 to 300	144	

LEYG□M, LEYG□L Common

Size	Stroke range [mm]	A	B	C	DA	EA	EB	EH	EV	FA	FB	FC	G	GA	H	J	K	M	NA	NB	NC
25	Up to 39	141.5	116	50	20	46	85	103	52.3	11	14.5	12.5	5.4	40.3	98.8	30.8	29	34	M5 x 0.8	8	6.5
	40 to 100			67.5																	
	101 to 124	166.5	141	84.5																	
	125 to 200			102																	
	201 to 300			102																	
32	Up to 39	160.5	130	55	25	60	101	123	63.8	12	18.5	16.5	5.4	50.3	125.8	38.3	30	40	M6 x 1.0	10	8.5
	40 to 100			68																	
	101 to 124	190.5	160	85																	
	125 to 200			102																	
	201 to 300			102																	

Size	Stroke range [mm]	OA	OB	P	Q	S	T	U	V	WA	WB	WC	X	XA	XB	Y	Z
25	Up to 39	M6 x 1.0	12	80	18	30	95	6.8	40	35	26	70	54	4	5	26.5	8.5
	40 to 100									50	33.5						
	101 to 124									70	43.5	95					
	125 to 200									85	51						
	201 to 300									85	51						
32	Up to 39	M6 x 1.0	12	95	28	40	117	7.3	60	40	28.5	75	64	5	6	34	8.5
	40 to 100									50	33.5						
	101 to 124									70	43.5	105					
	125 to 200									85	51						
	201 to 300									85	51						

Size	Incremental encoder						Absolute encoder					
	Without lock			With lock			Without lock			With lock		
	VA	VB	VC	VA	VB	VC	VA	VB	VC	VA	VB	VC
25	120	87	14.1	156.9	123.9	15.8	115.4	82.4	14.1	156.5	123.5	15.8
32	128.2	88.2	17.1	156.8	116.8	17.1	116.6	76.6	17.1	156.1	116.1	17.1

Model Selection
 LEY
 LEYG
 LECA6
 LECP6
 LEC-G
 LEC-P1
 LEC-PA
 JXC□1
 JXC7□□□□□□□□
 AC Servo Motor
 LEY
 LEYG
 LEC□
 LECSS-T
 LECY□
 Specific Product Precautions

Series LEYG

AC Servo Motor

Dimensions: In-line Motor

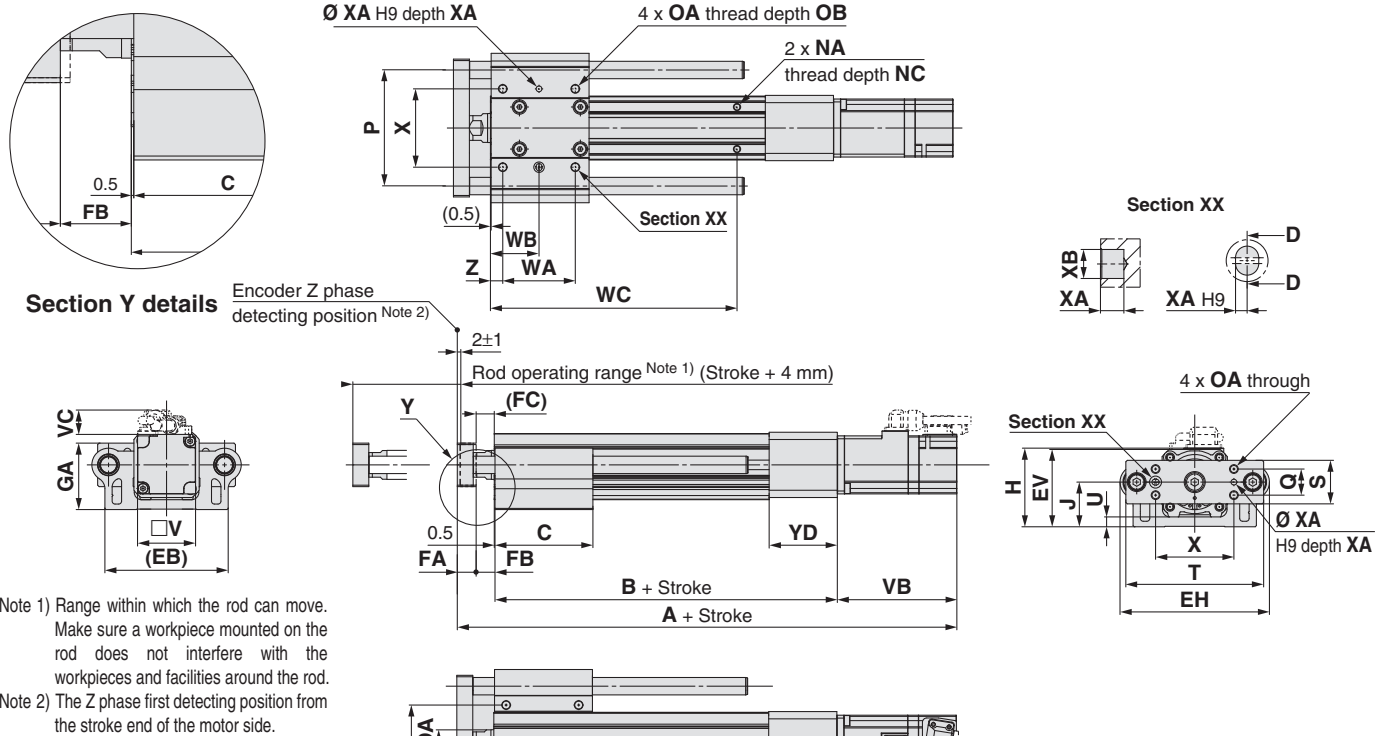

LEYG□L (Ball bushing bearing) [mm]

Size	Stroke range [mm]	L	DB
25	Up to 114	91	10
	115 to 190	115	
	191 to 300	133	
32	Up to 114	97.5	13
	115 to 190	116.5	
	191 to 300	34	

LEYG□M (Sliding bearing) [mm]

Size	Stroke range [mm]	L	DB
25	Up to 59	67.5	12
	60 to 185	100.5	
	186 to 300	138	
32	Up to 59	74	16
	60 to 185	107	
	186 to 300	144	

LEYG□M, LEYG□L Common [mm]

Size	Stroke range [mm]	B	C	DA	EA	EB	EH	EV	FA	FB	FC	G	GA	H	J	K	NA	NC
25	Up to 39	136.5	50	20	46	85	103	52.3	11	14.5	12.5	5.4	40.3	53.3	30.8	29	M5 x 0.8	6.5
	40 to 100		67.5															
	101 to 124		84.5															
	125 to 200		102															
	201 to 300		102															
32	Up to 39	156	55	25	60	101	123	63.8	12	18.5	16.5	5.4	50.3	68.3	38.3	30	M6 x 1.0	8.5
	40 to 100		68															
	101 to 124		85															
	125 to 200		85															
	201 to 300		102															

Size	Stroke range [mm]	OA	OB	P	Q	S	T	U	V	WA	WB	WC	X	XA	XB	YD	Z
25	Up to 39	M6 x 1.0	12	80	18	30	95	6.8	40	35	26	70	54	4	5	47	8.5
	40 to 100									50	33.5						
	101 to 124									70	43.5						
	125 to 200									85	51						
	201 to 300									85	51						
32	Up to 39	M6 x 1.0	12	95	28	40	117	7.3	60	40	28.5	75	64	5	6	60	8.5
	40 to 100									50	33.5						
	101 to 124									70	43.5						
	125 to 200									85	51						
	201 to 300									85	51						

Size	Stroke range [mm]	Incremental encoder						Absolute encoder					
		Without lock			With lock			Without lock			With lock		
		A	VB	VC	A	VB	VC	A	VB	VC	A	VB	VC
25	15 to 100	249	87	14.6	285.9	123.9	16.3	244.4	82.4	14.6	285.5	123.5	16.3
	105 to 300	274			310.9			269.4			315.5		
32	15 to 100	274.7	88.2	17.1	303.3	116.8	17.1	263.1	76.6	17.1	302.6	116.1	17.1
	105 to 300	304.7			333.3			293.1			332.6		

Support Block

● Guide for support block application

When the stroke exceeds 100 mm and the mounting orientation is horizontal, the body will be bent. Mounting the support block is recommended. (Please order it separately from the models shown below.)

Support Block Model

LEYG-S 025

● Size

025	For size 25
032	For size 32

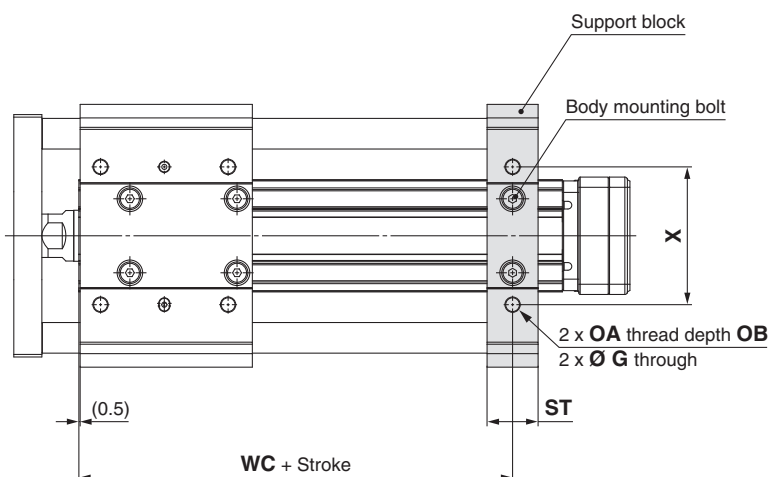
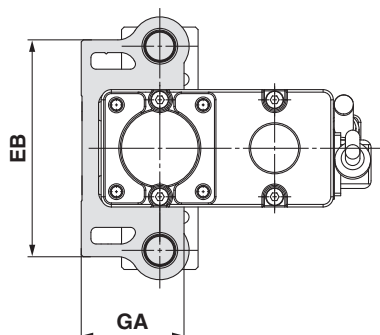
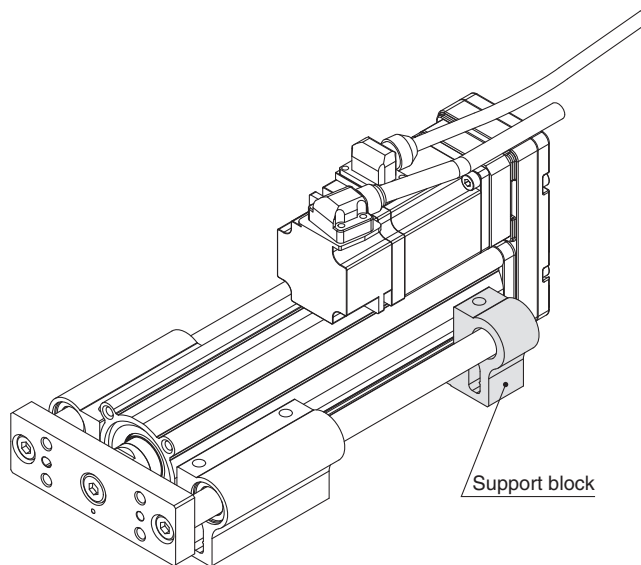

⚠ Caution

Do not install the body using only a support block. The support block should be used only for support.

Size	Model	Stroke range	EB	G	GA	OA	OB	ST	WC	X
25	LEYG-S025	100st or less	85	5.4	40.3	M6 x 1.0	12	20	70	54
		101st or more, 300st or less							95	
32	LEYG-S032	100st or less	101	5.4	50.3	M6 x 1.0	12	22	75	64
		101st or more, 300st or less							105	

* Two body mounting bolts are included with the support block.

* The through holes of the LEYG-S032 cannot be used. Use taps on the bottom.

Model Selection

LEYG

LEYG

LECA6
LECP6

LEC-G

LECP1

LECPA

JXC01

JXC70/83/92/99

LEYG

AC Servo Motor
LEYG

LECS

LECS-T

LECY

Specific Product Precautions



Series LEY/LEYG Electric Actuators/ Specific Product Precautions 1

Be sure to read this before handling. Refer to the back cover for Safety Instructions. For Electric Actuator Precautions, refer to “Handling Precautions for SMC Products” and the Operation Manual on SMC website, <http://www.smc.eu>

Design/Selection

Warning

- Do not apply a load in excess of the specification limits.**
Select a suitable actuator by work load and allowable lateral load on the rod end. If the product is used outside of the specification limits, the eccentric load applied to the piston rod will be excessive and have adverse effects such as creating play on the sliding parts of the piston rod, degrading accuracy and shortening the life of the product.
- Do not use the product in applications where excessive external force or impact force is applied to it.**
This can cause failure.
- When used as a stopper, select the LEYG series “Sliding bearing” for a stroke of 30 mm or less.**
- When used as a stopper, fix the main body with a guide attachment (“Top mounting” or “Bottom mounting”).**
If the end of the actuator is used to fix the main body (end mounting), the excessive load acts on the actuator, which adversely affects the operation and life of the product.

Handling

Caution

- Use the product within the specified pushing speed range for the pushing operation.**
It may lead to damage and malfunction.
- Do not apply a load, impact or resistance in addition to the transferred load during return to origin.**
Additional force will cause the displacement of the origin position since it is based on detected motor torque.
- Do not scratch or dent the sliding parts of the piston rod, by striking or attaching objects.**
The piston rod and guide rod are manufactured to precise tolerances, even a slight deformation may cause malfunction.
- When an external guide is used, connect it in such a way that no impact or load is applied to it.**
Use a freely moving connector (such as a floating joint).
- Do not operate by fixing the piston rod and moving the actuator body.**
Excessive load will be applied to the piston rod, leading to damage to the actuator and reduced the life of the product.

Handling

Caution

- When an actuator is operated with one end fixed and the other free (ends tapped or flange type), a bending moment may act on the actuator due to vibration generated at the stroke end, which can damage the actuator. In such a case, install a mounting bracket to suppress the vibration of the actuator body or reduce the speed so that the actuator does not vibrate at the stroke end.**
Also, use a mounting bracket when moving the actuator body or when a long stroke actuator is mounted horizontally and fixed at one end.
- Avoid using the electric actuator in such a way that rotational torque would be applied to the piston rod.**
This may cause deformation of the non-rotating guide, abnormal responses of the auto switch, play in the internal guide or an increase in the sliding resistance. Refer to the table below for the approximate values of the allowable range of rotational torque.

Allowable rotational torque [N·m] or less	LEY25□□	LEY32□□	LEY63
	1.1	1.4	2.8

When screwing in a bracket or nut to the end of the piston rod, hold the flats of the rod end with a wrench (the piston rod should be fully retracted). Do not apply tightening torque to the non-rotating mechanism.

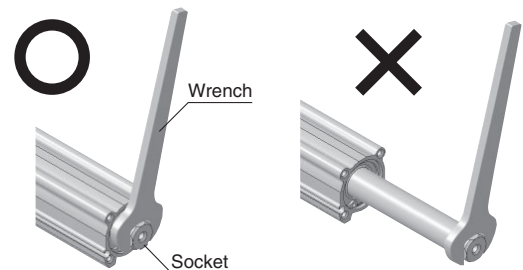

- When rotational torque is applied to the end of the plate, use it within the allowable range. [Series LEYG]**
This may cause deformation of the guide rod and bushing, play in the guide or an increase in the sliding resistance.



Series LEY/LEYG Electric Actuators/ Specific Product Precautions 2

Be sure to read this before handling. Refer to the back cover for Safety Instructions. For Electric Actuator Precautions, refer to “Handling Precautions for SMC Products” and the Operation Manual on SMC website, <http://www.smc.eu>

Handling

Caution

9. When mounting the product, keep a 40 mm or longer diameter for bends in the cable.

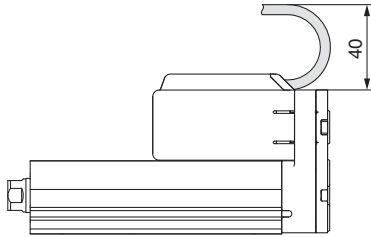

10. When mounting a bolt, workpiece or jig, hold the flats of the piston rod end with a wrench so that the piston rod does not rotate. The bolt should be tightened within the specified torque range.

This may cause abnormal responses of the auto switch, play in the internal guide or an increase in the sliding resistance.

11. When mounting the product and/or a workpiece, tighten the mounting screws within the specified torque range.

Tightening the screws with a higher torque than recommended may cause a malfunction, whilst the tightening with a lower torque can cause the displacement of the mounting position or in extreme conditions the actuator could become detached from its mounting position.

<Series LEY>

Workpiece fixed/Rod end female thread

Model	Screw size	Max. tightening torque [N·m]	Max. screw-in depth [mm]	End socket width across flats [mm]
LEY25	M8 x 1.25	12.5	13	17
LEY32	M8 x 1.25	12.5	13	22
LEY63	M16 x 2	106	21	36

End socket

Workpiece fixed/Rod end male thread

(When “Rod end male thread” is selected.)

Model	Thread size	Max. tightening torque [N·m]	Effective thread length [mm]	End socket width across flats [mm]
LEY25	M14 x 1.5	65.0	20.5	17
LEY32	M14 x 1.5	65.0	20.5	22
LEY63	M18 x 1.5	97.0	26	36

Rod end nut

End socket

Model	Rod end nut		End bracket screw-in depth [mm]
	Width across flats [mm]	Length [mm]	
LEY25	22	8	8 or more
LEY32	22	8	8 or more
LEY63	27	11	18

End bracket screw-in depth

* Rod end nut is an accessory.

Caution

Body fixed/Body bottom tapped style

(When “Body bottom tapped” is selected.)

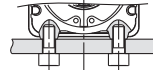

Model	Screw size	Max. tightening torque [N·m]	Max. screw-in depth [mm]
LEY25	M5 x 0.8	3.0	6.5
LEY32	M6 x 1.0	5.2	8.8
LEY63	M8 x 1.25	12.5	10

Body fixed/Rod side/Head side tapped style

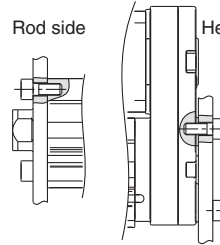

Model	Screw size	Max. tightening torque [N·m]	Max. screw-in depth [mm]
LEY25	M5 x 0.8	3.0	8
LEY32	M6 x 1.0	5.2	10
LEY63	M8 x 1.25	12.5	16

* Except the LEY□D.

<Series LEYG>

Workpiece fixed/Plate tapped style

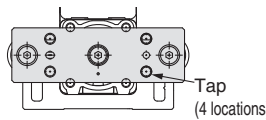

Model	Screw size	Max. tightening torque [N·m]	Max. screw-in depth [mm]
LEYG25 ^M	M6 x 1.0	5.2	11
LEYG32 ^M	M6 x 1.0	5.2	12

Tap (4 locations)

Body fixed/Top mounting

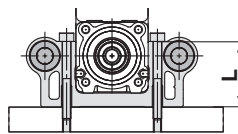

Model	Screw size	Max. tightening torque [N·m]	Length: L [mm]
LEYG25 ^M	M5 x 0.8	3.0	40.3
LEYG32 ^M	M5 x 0.8	3.0	50.3

Body fixed/Bottom mounting

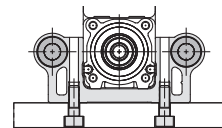

Model	Screw size	Max. tightening torque [N·m]	Max. screw-in depth [mm]
LEYG25 ^M	M6 x 1.0	5.2	12
LEYG32 ^M	M6 x 1.0	5.2	12

Body fixed/Head side tapped style

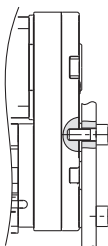

Model	Screw size	Max. tightening torque [N·m]	Max. screw-in depth [mm]
LEYG25 ^M	M5 x 0.8	3.0	8
LEYG32 ^M	M6 x 1.0	5.2	10

Model Selection

LEY

LEYG

LECA6
LECP6

LEC-G

LECP1

LECPA

JXC□1

JXC7303/92/93

LEY

LEYG

LECS□

LECS-T

LECY□

Specific Product Precautions



Series LEY/LEYG Electric Actuators/ Specific Product Precautions 3

Be sure to read this before handling. Refer to the back cover for Safety Instructions. For Electric Actuator Precautions, refer to “Handling Precautions for SMC Products” and the Operation Manual on SMC website, <http://www.smc.eu>

Handling

⚠ Caution

12. Keep the flatness of the mounting surface within the following ranges when mounting the actuator body and workpiece.

Unevenness of a workpiece or base mounted on the body of the product may cause an increase in the sliding resistance.

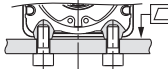
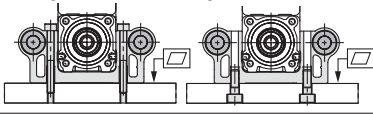
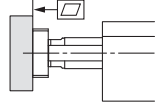
Model	Mounting position	Flatness
LEY□	Body/Body bottom 	0.02 mm or less
LEYG□	Top mounting/Bottom mounting 	0.02 mm or less
	Workpiece/Plate mounting 	0.05 mm or less

13. When using auto switch with the guide rod type LEYG series, the following limits will be in effect. Please select the product while paying attention to this.

- Insert the auto switch from the front side with rod (plate) sticking out.
- The auto switches with perpendicular electrical entry cannot be used.
- For the parts hidden behind the guide attachment (Rod stick out side), the auto switch cannot be fixed.
- Please consult with SMC when using auto switch on the rod stick out side.

Enclosure

IP - □ □

First characteristic numeral • Second characteristic numeral

• First Characteristics: Degrees of protection against solid foreign objects

0	Non-protected
1	Protected against solid foreign objects of 50 mmØ and greater
2	Protected against solid foreign objects of 12 mmØ and greater
3	Protected against solid foreign objects of 2.5 mmØ and greater
4	Protected against solid foreign objects of 1.0 mmØ and greater
5	Dust-protected
6	Dust-tight

• Second Characteristics: Degrees of protection against water

0	Non-protected	—
1	Protected against vertically falling water drops	Drip-proof type 1
2	Protected against vertically falling water drops when enclosure tilted up to 15°	Drip-proof type 2
3	Protected against rainfall when enclosure tilted up to 60°	Rain-proof type
4	Protected against splashing water	Splash-proof type
5	Protected against water jets	Water-jet-proof type
6	Protected against powerful water jets	Powerful water-jet-proof type
7	Protected against the effects of temporary immersion in water	Immersion type
8	Protected against the effects of continuous immersion in water	Submersible type

Example) IP65: Dust-tight, Water-jet-proof type

“Water-jet-proof type” means that no water intrudes inside an equipment that could hinder from operating normally by means of applying water for 3 minutes in the prescribed manner. Take appropriate protection measures, since a device is not usable in an environment where a droplet of water is splashed constantly.



Series LEY/LEYG

Electric Actuators/ Specific Product Precautions 4

Be sure to read this before handling. Refer to the back cover for Safety Instructions. For Electric Actuator Precautions, refer to “Handling Precautions for SMC Products” and the Operation Manual on SMC website, <http://www.smc.eu>

Maintenance

Warning

1. Ensure that the power supply is stopped and the workpiece is removed before starting maintenance work or replacement of the product.

- **Maintenance frequency**

Perform maintenance according to the table below.

Frequency	Appearance check	Belt check
Inspection before daily operation	○	—
Inspection every 6 months/ 250 km/5 million cycles*	○	○

* Select whichever comes first.

- **Items for visual appearance check**

1. Loose set screws, Abnormal dirt
2. Check of flaw and cable joint
3. Vibration, Noise

- **Items for belt check**

Stop operation immediately and replace the belt when belt appear to be below. Further, ensure your operating environment and conditions satisfy the requirements specified for the product.

- a. **Tooth shape canvas is worn out**

Canvas fiber becomes fuzzy. Rubber is removed and the fiber becomes whitish. Lines of fibers become unclear.

- b. **Peeling off or wearing of the side of the belt**

Belt corner becomes round and frayed thread sticks out.

- c. **Belt partially cut**

Belt is partially cut. Foreign matter caught in teeth other than cut part causes flaw.

- d. **Vertical line of belt teeth**

Flaw which is made when the belt runs on the flange.

- e. **Rubber back of the belt is softened and sticky**

- f. **Crack on the back of the belt**

Model Selection

Servo Motor (24 VDC)/Step Motor (Servo/24 VDC)
LEY
LEYG

LECA6
LECP6

LEC-G

LECP1

LECPA

JXC□1

JXC7/□□3/□□□□

AC Servo Motor
LEY

LEYG

LECS□

LECS-T

LECY□

Specific Product Precautions

AC Servo Motor Driver

Series **LECS**□

Pulse Input Type/
Positioning Type



Incremental Type
Series LECSA

Pulse Input Type



Absolute Type
Series LECSB

CC-Link Direct Input Type



Absolute Type
Series LECSC

SSCNET III Type



Absolute Type
Series LECSS

 Type



Absolute Type
Series LECSS-T

AC Servo Motor Driver

Series LECS□

Power supply voltage 100 to 120 VAC
200 to 230 VAC

Motor capacity 100/200/400 W

Model Selection

Incremental Type

Series LECSA (Pulse input type/Positioning type)



- Up to 7 positioning points by point table
- Input type: Pulse input
- Control encoder: Incremental 17-bit encoder (Resolution: 131072 pulse/rev)
- Parallel input: 6 inputs
output: 4 outputs

Servo Motor (24 VDC)/Step Motor (Servo/24 VDC)

LEY

LEYG

LECA6
LECP6

LEC-G

LECP1

LECPA

JXC□1

JXC73/83/92/93

LEY

AC Servo Motor

LEYG

LECS□

LECS-T

LECY□

Specific Product Precautions

Absolute Type

Series LECSB (Pulse input type)



- Input type: Pulse input
- Control encoder: Absolute 18-bit encoder (Resolution: 262144 pulse/rev)
- Parallel input: 10 inputs
output: 6 outputs

Series LECS (CC-Link direct input type)



- Position data/speed data setting and operation start/stop
- Positioning by up to 255 point tables (when 2 stations occupied)
- Up to 32 drivers connectable (when 2 stations occupied) with CC-Link communication
- Applicable Fieldbus protocol: CC-Link (Ver. 1.10, max. communication speed: 10 Mbps)
- Control encoder: Absolute 18-bit encoder (Resolution: 262144 pulse/rev)

CC-Link

Series LECS (SSCNET III type)



- Compatible with Mitsubishi Electric's servo system controller network
- Reduced wiring and SSCNET III optical cable for one-touch connection
- SSCNET III optical cable provides enhanced noise resistance
- Up to 16 drivers connectable with SSCNET III communication
- Applicable Fieldbus protocol: SSCNET III (High-speed optical communication, max. one-way communication speed: 100 Mbps)
- Control encoder: Absolute 18-bit encoder (Resolution: 262144 pulse/rev)

AC Servo Motor Driver

Incremental Type



Series LECSA

(Pulse Input Type/Positioning Type)



Absolute Type

Series LECSB/LECSC/LECSS

(Pulse Input Type) (CC-Link Direct Input Type) (SSCNET III Type)

How to Order

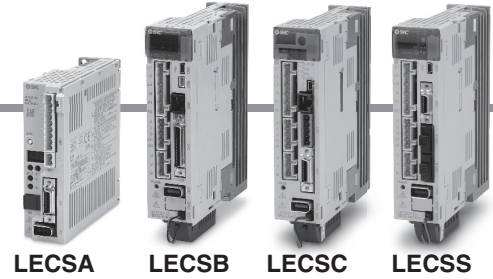

Driver

LECSA 1 - S1

Driver type

A	Pulse input type/Positioning type (For incremental encoder)
B	Pulse input type (For absolute encoder)
C	CC-Link direct input type (For absolute encoder)
S	SSCNET III type (For absolute encoder)

Power supply voltage

1	100 to 120 VAC, 50 / 60 Hz
2	200 to 230 VAC, 50 / 60 Hz

Compatible motor type

Symbol	Type	Capacity	Encoder
S1	AC servo motor (S2)	100 W	Incremental
S3	AC servo motor (S3)	200 W	
S4	AC servo motor (S4)*	400 W	
S5	AC servo motor (S6)	100 W	Absolute
S7	AC servo motor (S7)	200 W	
S8	AC servo motor (S8)*	400 W	

* Only available for power supply voltage "200 to 230 VAC".

Dimensions

LECSA □

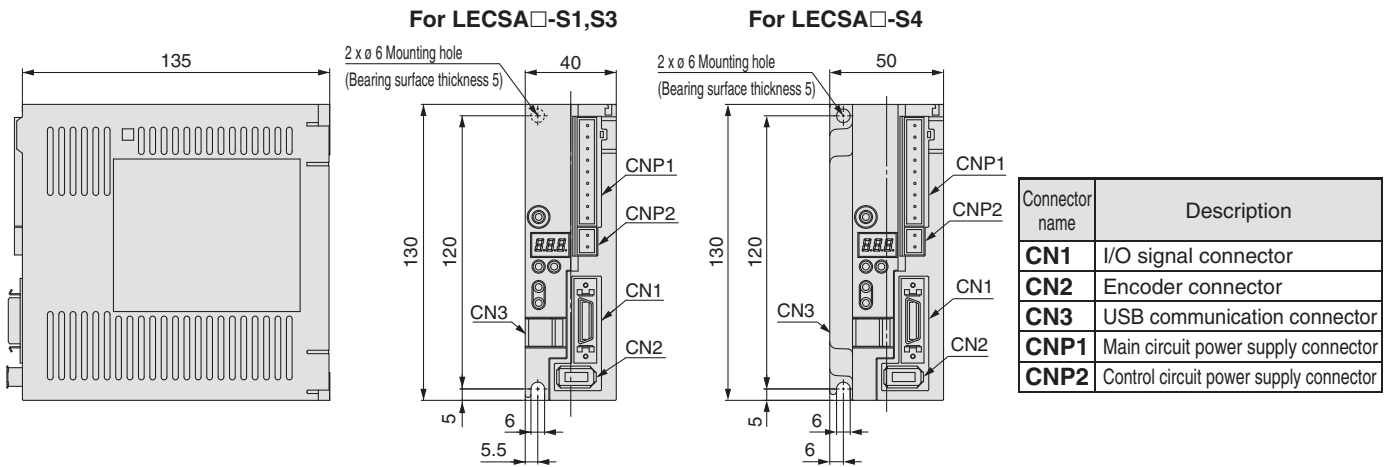

LECSB □

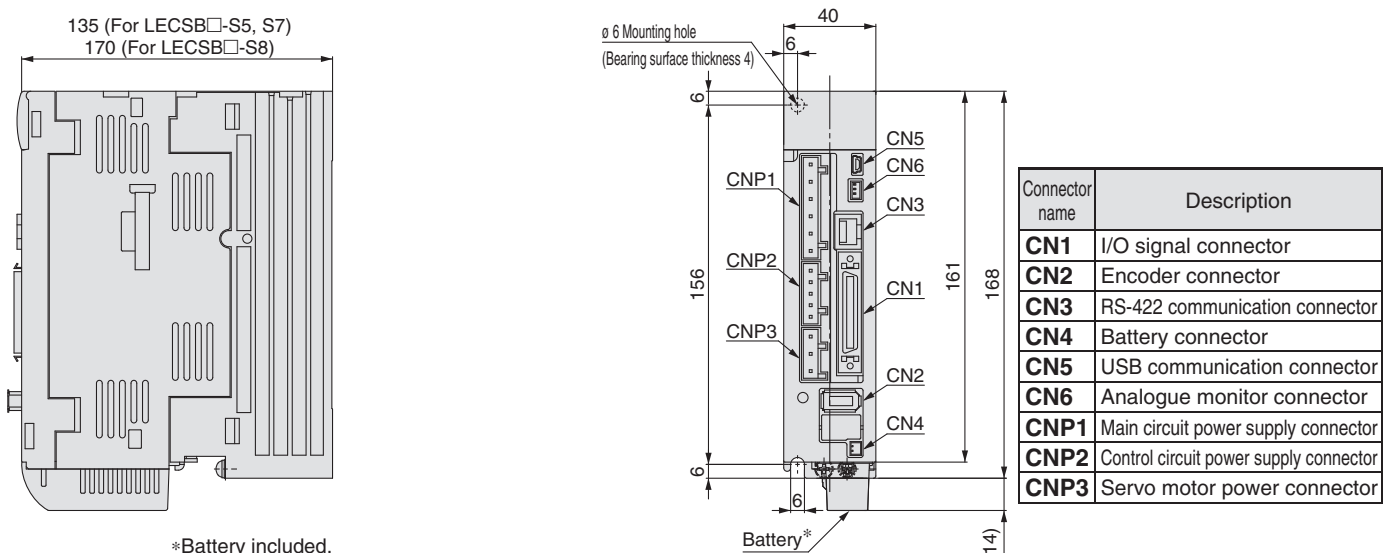

*Battery included.

Dimensions

LECS□

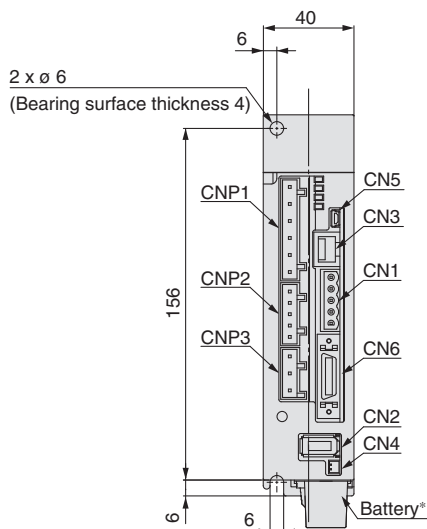
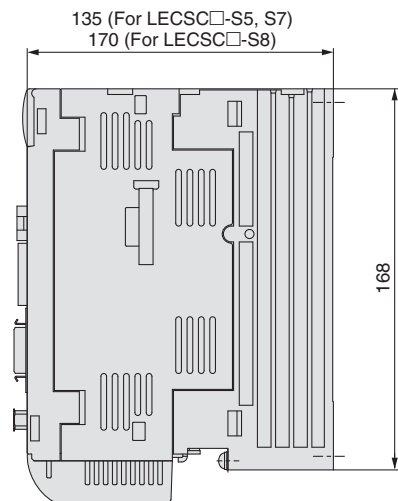

Connector name	Description
CN1	CC-Link connector
CN2	Encoder connector
CN3	RS-422 communication connector
CN4	Battery connector
CN5	USB communication connector
CN6	I/O signal connector
CNP1	Main circuit power supply connector
CNP2	Control circuit power supply connector
CNP3	Servo motor power connector

* Battery included.

LECS□

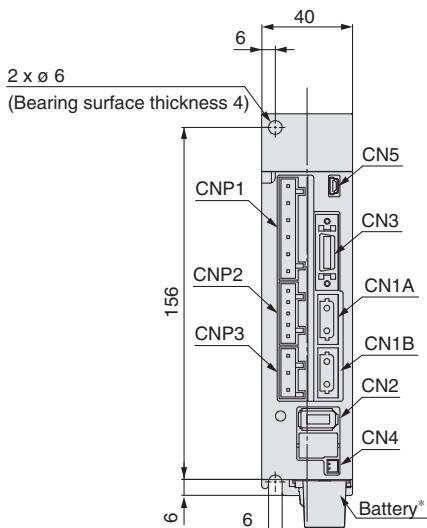
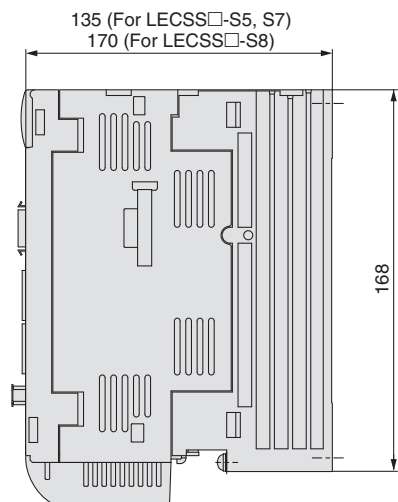

Connector name	Description
CN1A	Front axis connector for SSCNET III optical cable
CN1B	Rear axis connector for SSCNET III optical cable
CN2	Encoder connector
CN3	I/O signal connector
CN4	Battery connector
CN5	USB communication connector
CNP1	Main circuit power supply connector
CNP2	Control circuit power supply connector
CNP3	Servo motor power connector

* Battery included.

Model Selection

AC Servo Motor (24 VDC) (Step Motor (Servo/24 VDC))

LECS□

LECS-T

LECY□

LECS□

LEYG

LEY

JXC□1

JXC7303/02/03

LECP6

LECP-G

LECP1

LECPA

LEYG

LEY

Specific Product Precautions

Series LECS□

Specifications

Series LECSA

Model		LECSA1-S1	LECSA1-S3	LECSA2-S1	LECSA2-S3	LECSA2-S4
Compatible motor capacity [W]		100	200	100	200	400
Compatible encoder		Incremental 17-bit encoder (Resolution: 131072 p/rev)				
Main power supply	Power voltage [V]	Single phase 100 to 120 VAC (50 / 60 Hz)		Single phase 200 to 230 VAC (50 / 60 Hz)		
	Allowable voltage fluctuation [V]	Single phase 85 to 132 VAC		Single phase 170 to 253 VAC		
	Rated current [A]	3.0	5.0	1.5	2.4	4.5
Control power supply	Control power supply voltage [V]	24 VDC				
	Allowable voltage fluctuation [V]	21.6 to 26.4 VDC				
	Rated current [A]	0.5				
Parallel input		6 inputs				
Parallel output		4 outputs				
Max. input pulse frequency [pps]		1 M (for differential receiver), 200 k (for open collector)*2				
Function	In-position range setting [pulse]	0 to ±65535 (Command pulse unit)				
	Error excessive	±3 rotations				
	Torque limit	Parameter setting				
	Communication	USB communication				
Operating temperature range [°C]		0 to 55 (No freezing)				
Operating humidity range [%RH]		90 or less (No condensation)				
Storage temperature range [°C]		-20 to 65 (No freezing)				
Storage humidity range [%RH]		90 or less (No condensation)				
Insulation resistance [MΩ]		Between the housing and SG: 10 (500 VDC)				
Weight [g]		600				700

Series LECSB

Model		LECSB1-S5	LECSB1-S7	LECSB2-S5	LECSB2-S7	LECSB2-S8
Compatible motor capacity [W]		100	200	100	200	400
Compatible encoder		Absolute 18-bit encoder (Resolution: 262144 p/rev)				
Main power supply	Power voltage [V]	Single phase 100 to 120 VAC (50 / 60 Hz)		Three phase 200 to 230 VAC (50 / 60 Hz) Single phase 200 to 230 VAC (50 / 60 Hz)		
	Allowable voltage fluctuation [V]	Single phase 85 to 132 VAC		Three phase 170 to 253 VAC Single phase 170 to 253 VAC		
	Rated current [A]	3.0	5.0	0.9	1.5	2.6
Control power supply	Control power supply voltage [V]	Single phase 100 to 120 VAC (50 / 60 Hz)		Single phase 200 to 230 VAC (50 / 60 Hz)		
	Allowable voltage fluctuation [V]	Single phase 85 to 132 VAC		Single phase 170 to 253 VAC		
	Rated current [A]	0.4		0.2		
Parallel input		10 inputs				
Parallel output		6 outputs				
Max. input pulse frequency [pps]		1 M (for differential receiver), 200 k (for open collector)				
Function	In-position range setting [pulse]	0 to ±10000 (Command pulse unit)				
	Error excessive	±3 rotations				
	Torque limit	Parameter setting or external analogue input setting (0 to 10 VDC)				
	Communication	USB communication, RS422 communication*1				
Operating temperature range [°C]		0 to 55 (No freezing)				
Operating humidity range [%RH]		90 or less (No condensation)				
Storage temperature range [°C]		-20 to 65 (No freezing)				
Storage humidity range [%RH]		90 or less (No condensation)				
Insulation resistance [MΩ]		Between the housing and SG: 10 (500 VDC)				
Weight [g]		800				1000

*1 USB communication and RS422 communication cannot be performed at the same time.

*2 If the command pulse train input is open collector method, it supports only to the sink (NPN) type interface. It does not correspond to the source (PNP) type interface.

Power Supply Wiring Example: LECSA

LECSA□-□

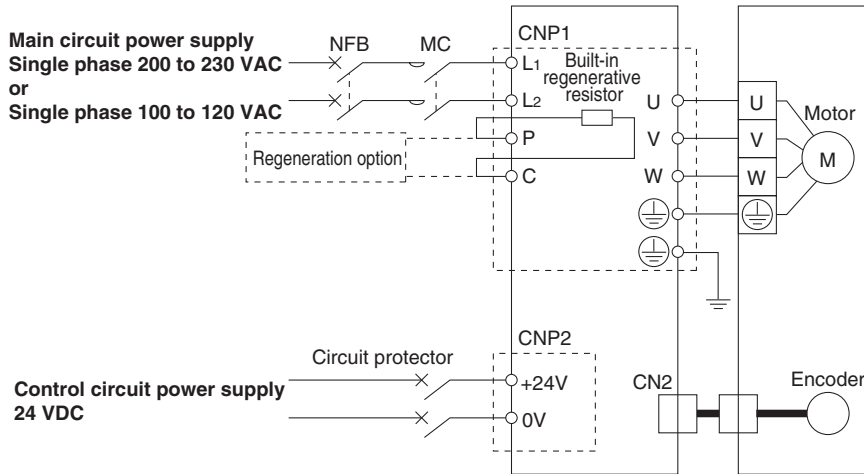

Main Circuit Power Supply Connector: CNP1 * Accessory

Terminal name	Function	Details
	Protective earth (PE)	Should be grounded by connecting the servo motor's earth terminal and the control panel's protective earth (PE).
L1	Main circuit power supply	Connect the main circuit power supply. LECSA1: Single phase 100 to 120 VAC, 50 / 60 Hz LECSA2: Single phase 200 to 230 VAC, 50 / 60 Hz
L2		
P	Regeneration option	Terminal to connect regeneration option LECSA□-S1: Not connected at time of shipping. LECSA□-S3, S4: Connected at time of shipping. * If regeneration option is required for "Model Selection", connect to this terminal.
C		
U	Servo motor power (U)	Connect to motor cable (U, V, W).
V	Servo motor power (V)	
W	Servo motor power (W)	

Control Circuit Power Supply Connector: CNP2 * Accessory

Terminal name	Function	Details
24V	Control circuit power supply (24 V)	24 V side of the control circuit power supply (24 VDC) supplied to the driver
0V	Control circuit power supply (0 V)	0 V side of the control circuit power supply (24 VDC) supplied to the driver

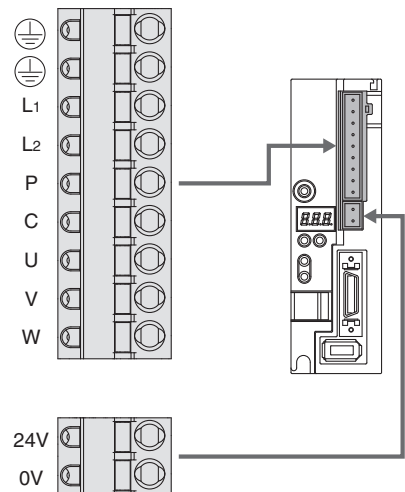

Control Signal Wiring Example: LECSB

This wiring example shows connection with a positioning unit (QD75D) manufactured by Mitsubishi Electric as when used in position control mode. Refer to the LECSB operation manual and any technical literature or operation manuals for your PLC and positioning unit before connecting to another PLC or positioning unit.

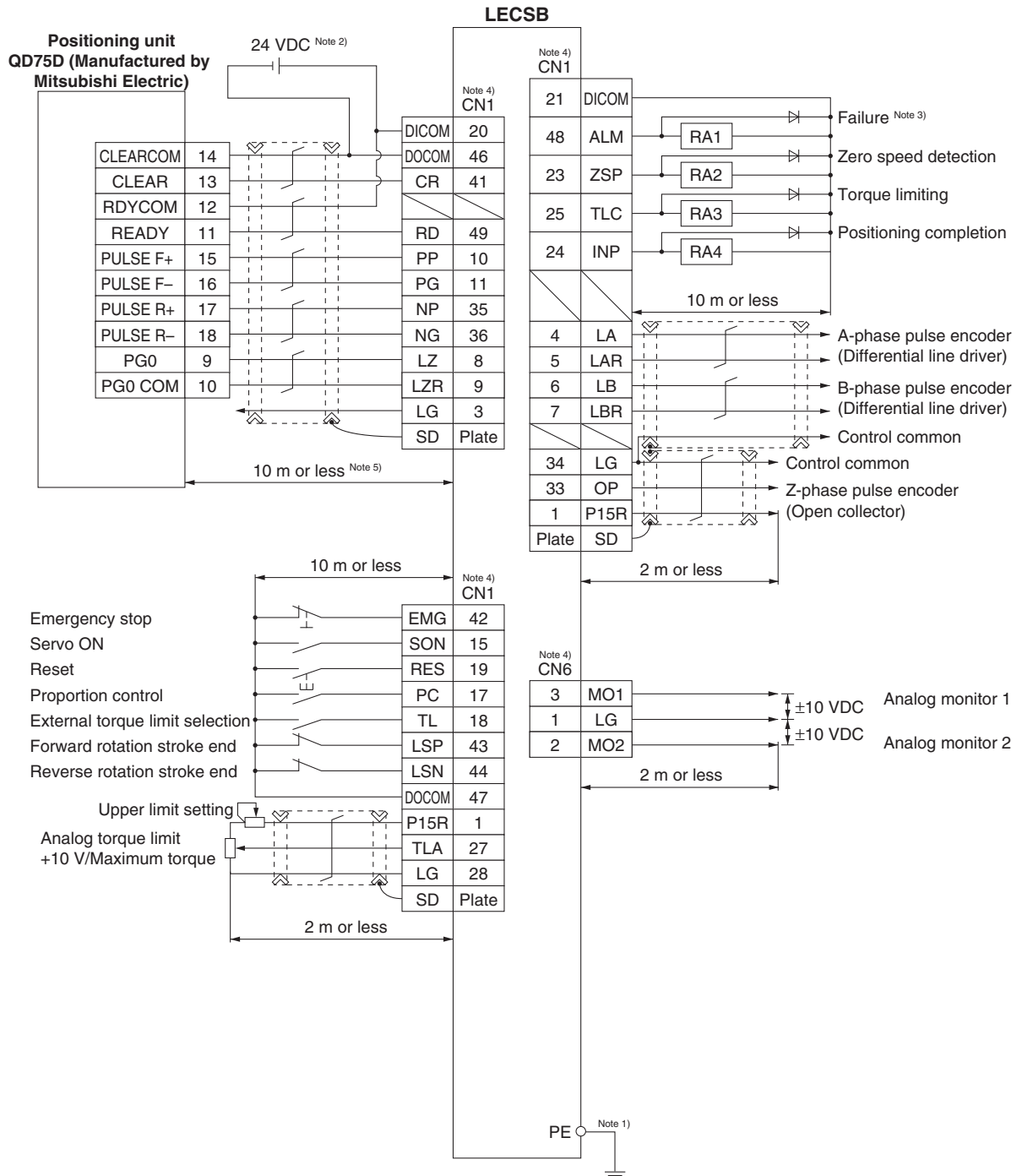

Note 1) For preventing electric shock, be sure to connect the driver's protective earth (PE) terminal (marked ⊕) to the control panel's protective earth (PE).
 Note 2) For interface use, supply 24 VDC ±10 % 300 mA using an external source.
 Note 3) The failure (ALM) is ON during normal conditions. When it is OFF (alarm occurs), stop the sequencer signal using the sequence program.
 Note 4) The same name signals are connected inside the driver.
 Note 5) For command pulse input with a differential line driver method. For open collector method, it is 2 m or less.
 Note 6) If the command pulse train input is open collector method, it supports only to the sink (NPN) type interface. It does not correspond to the source (PNP) type interface.

Control Signal Wiring Example: LECS

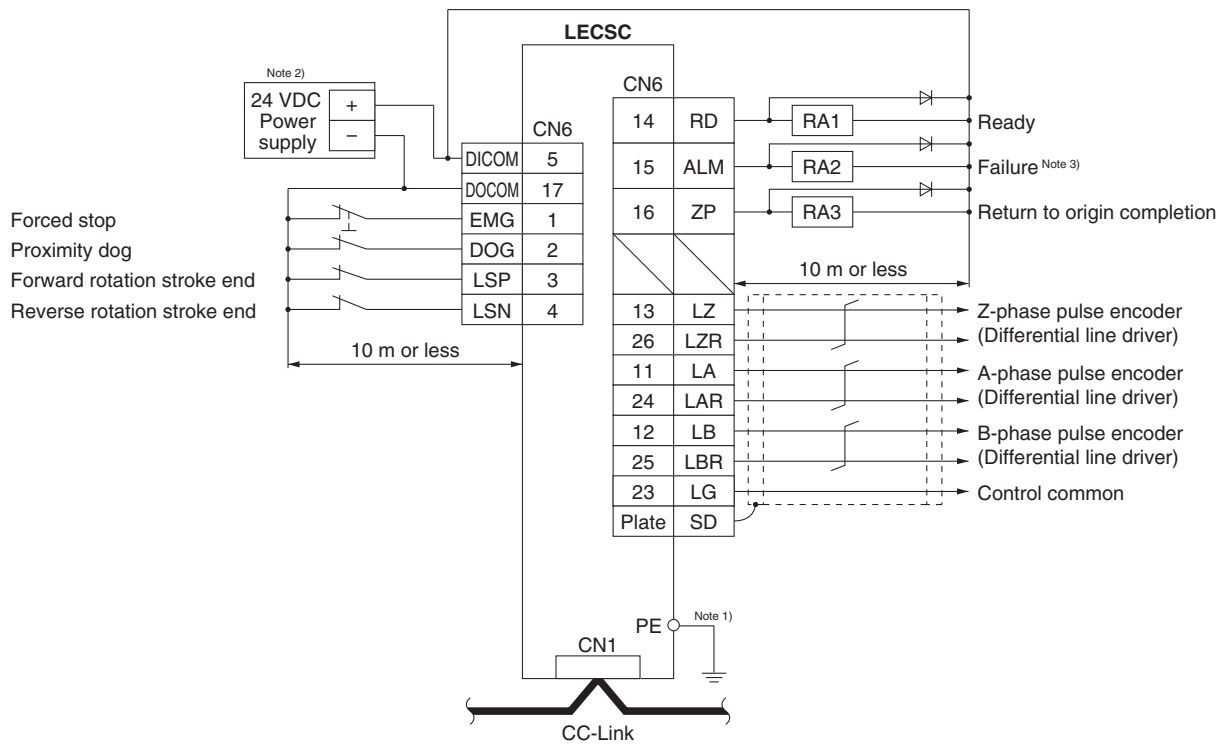

Note 1) For preventing electric shock, be sure to connect the driver's protective earth (PE) terminal (marked \oplus) to the control panel's protective earth (PE).

Note 2) For interface use, supply 24 VDC $\pm 10\%$ 150 mA using an external source.

Note 3) The failure (ALM) is ON during normal conditions. When it is OFF (alarm occurs), stop the sequencer signal using the sequence program.

Control Signal Wiring Example: LECS

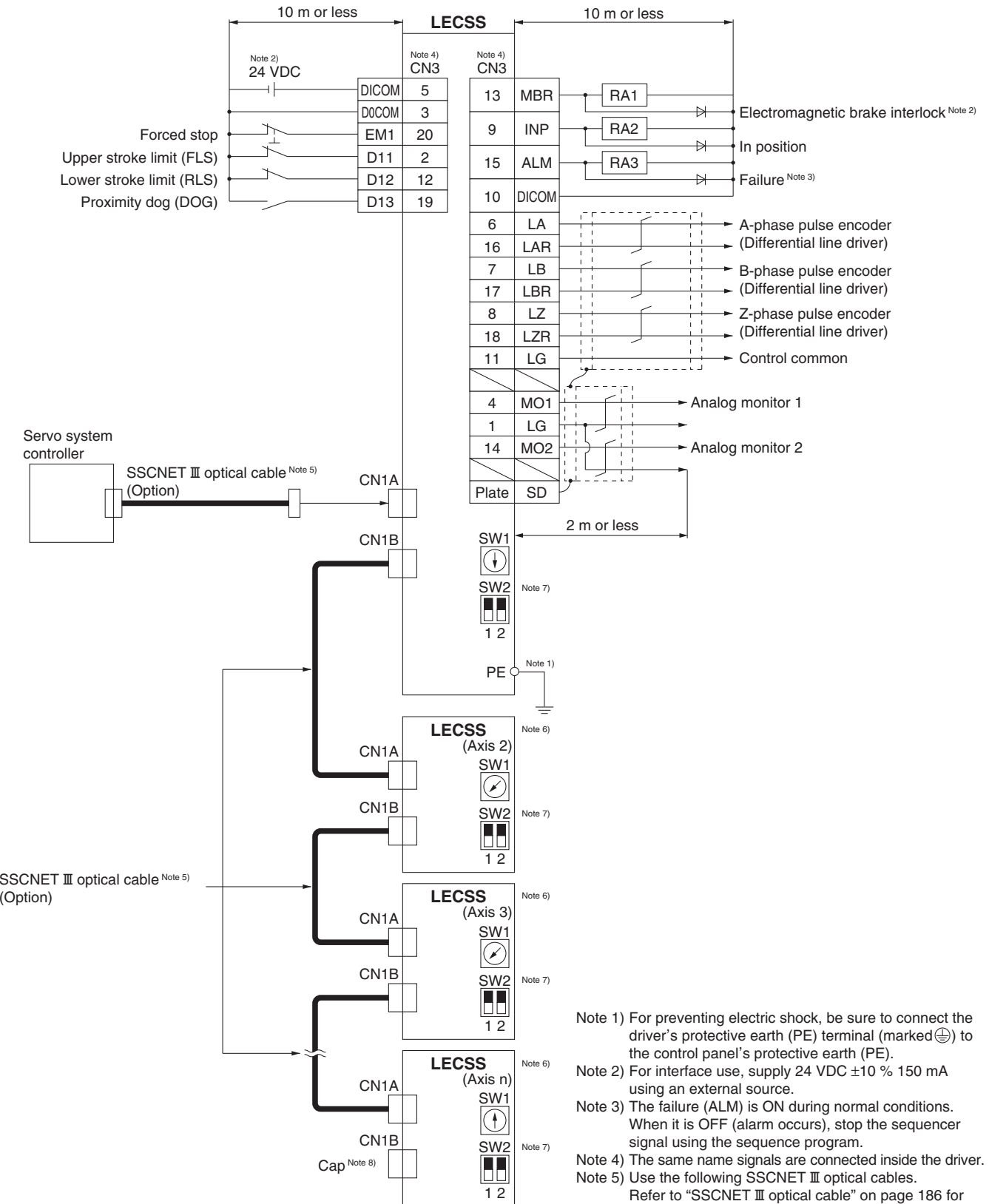

- Note 1) For preventing electric shock, be sure to connect the driver's protective earth (PE) terminal (marked ⊕) to the control panel's protective earth (PE).
- Note 2) For interface use, supply 24 VDC ±10 % 150 mA using an external source.
- Note 3) The failure (ALM) is ON during normal conditions. When it is OFF (alarm occurs), stop the sequencer signal using the sequence program.
- Note 4) The same name signals are connected inside the driver.
- Note 5) Use the following SSCNET III optical cables. Refer to "SSCNET III optical cable" on page 186 for cable models.

Cable	Cable model	Cable length
SSCNET III optical cable	LE-CSS-□	0.15 m to 3 m

- Note 6) Connections from Axis 2 onward are omitted.
- Note 7) Up to 16 axes can be set.
- Note 8) Be sure to place a cap on unused CN1A/CN1B.

Model Selection

LECS

LECS-T

LECY

AC Servo Motor

LEYG

LEY

JXC□1

JXC7□□□□□□□□

LECPA

LECP1

LEC-G

LECA6

LECP6

LEYG

LEY

Servo Motor (24 VDC) / Step Motor (Servo/24 VDC)

Series LECS□

Options

Motor cable, Lock cable, Encoder cable (LECS□ common)

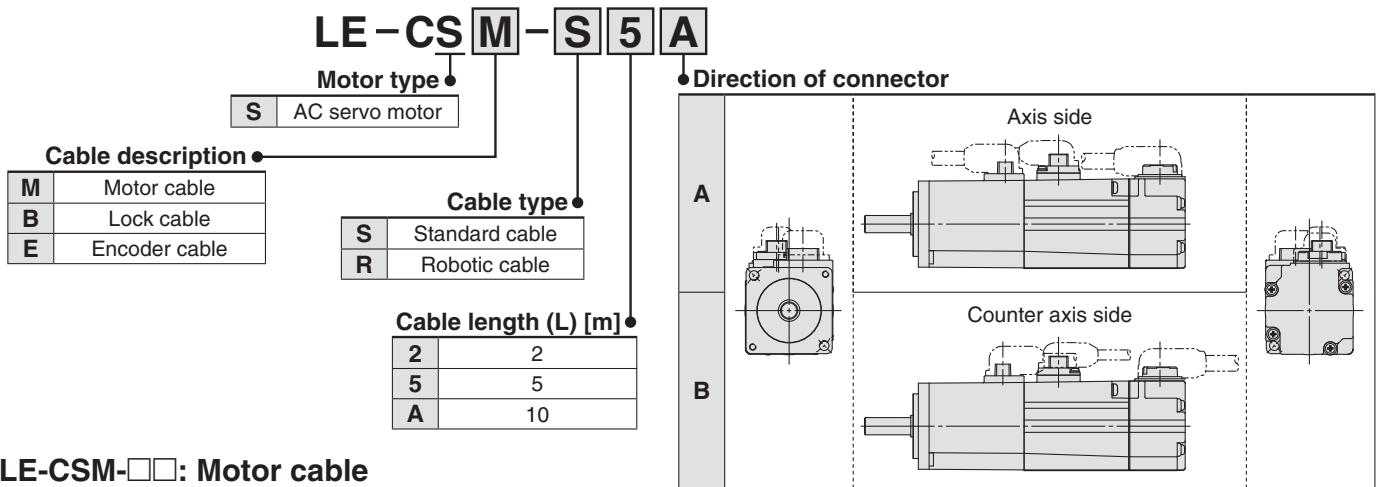

LE-CSM-□□: Motor cable

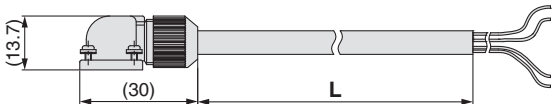

LE-CSB-□□: Lock cable

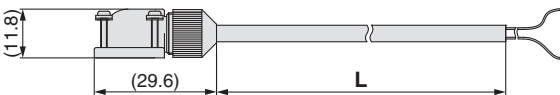

LE-CSE-□□: Encoder cable



Product no.	∅ D
LEC-CSM-S□A	6.2
LEC-CSM-S□B	6.2
LEC-CSM-R□A	5.7
LEC-CSM-R□B	5.7
LEC-CSB-S□A	4.7
LEC-CSB-S□B	4.7
LEC-CSB-R□A	4.5
LEC-CSB-R□B	4.5

I/O connector (Without cable, Connector only)

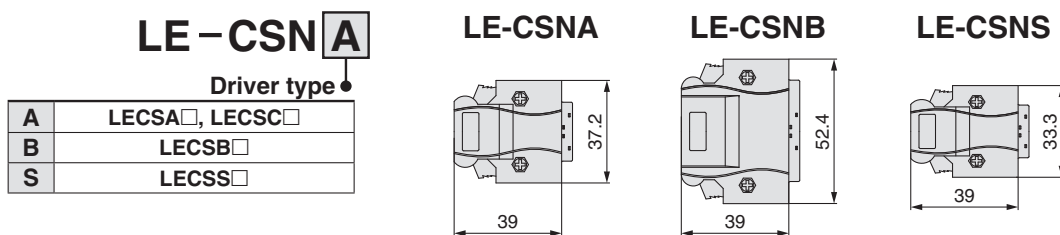

* LE-CSNA: 10126-3000PE (connector)/10326-52F0-008 (shell kit) manufactured by Sumitomo 3M Limited or equivalent item.
 LE-CSNB: 10150-3000PE (connector)/10350-52F0-008 (shell kit) manufactured by Sumitomo 3M Limited or equivalent item.
 LE-CSNS: 10120-3000PE (connector)/10320-52F0-008 (shell kit) manufactured by Sumitomo 3M Limited or equivalent item.
 * Applicable conductor size: AWG24 to 30

Options

SSCNET III optical cable

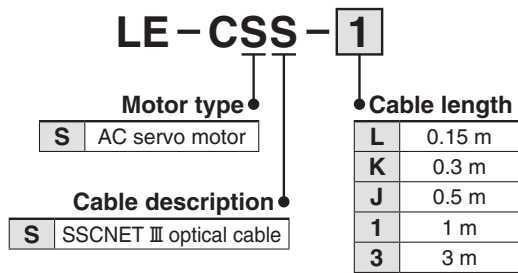

* LE-CSS-□ is MR-J3BUS□M manufactured by Mitsubishi Electric Corporation.

I/O cable

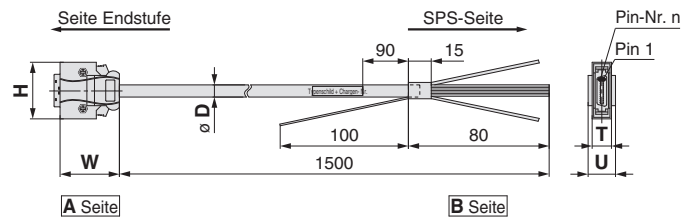
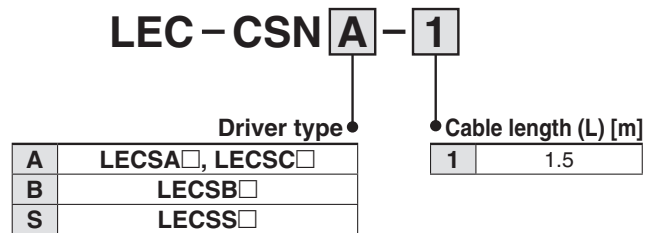

* LEC-CSNA-1: 10126-3000PE (connector)/10326-52F0-008 (shell kit) manufactured by Sumitomo 3M Limited or equivalent item.
 LEC-CSNB-1: 10150-3000PE (connector)/10350-52F0-008 (shell kit) manufactured by Sumitomo 3M Limited or equivalent item.
 LEC-CSNS-1: 10120-3000PE (connector)/10320-52F0-008 (shell kit) manufactured by Sumitomo 3M Limited or equivalent item.
 * Conductor size: AWG24

Dimensions/Pin No.

Product no.	W	H	T	U	Pin no. n
LEC-CSNA-1	39	37.2	12.7	14	14
LEC-CSNB-1		52.4		18	26
LEC-CSNS-1		33.3		14	21

Wiring

LEC-CSNA-1: Pin no. 1 to 26
 LEC-CSNB-1: Pin no. 1 to 50
 LEC-CSNS-1: Pin no. 1 to 20

A side	Pin no.		Insulation colour	Dot mark	Dot colour	Connector pin no.	Pair no. of wire		Insulation colour	Dot mark	Dot colour	
	1	2					1	2				
A side	1	1	Orange	■	Red	A side	19	10	Pink	■ ■	Red	
	2	1	Orange	■	Black		20	10	Pink	■ ■	Black	
	3	2	Light grey	■	Red		21	11	Orange	■ ■ ■ ■	Red	
	4	2	Light grey	■	Black		22	11	Orange	■ ■ ■ ■	Black	
	5	3	White	■	Red		23	12	Light Grey	■ ■ ■ ■	Red	
	6	3	White	■	Black		24	12	Light Grey	■ ■ ■ ■	Black	
	7	4	Yellow	■	Red		25	13	White	■ ■ ■ ■	Red	
	8	4	Yellow	■	Black		26	13	White	■ ■ ■ ■	Black	
	9	5	Pink	■	Red		27	14	Yellow	■ ■ ■ ■	Red	
	10	5	Pink	■	Black		28	14	Yellow	■ ■ ■ ■	Black	
	11	6	Orange	■ ■	Red		29	15	Pink	■ ■ ■ ■	Red	
	12	6	Orange	■ ■	Black		30	15	Pink	■ ■ ■ ■	Black	
	13	7	Light grey	■ ■ ■	Red		31	16	Orange	■ ■ ■ ■ ■	Red	
	14	7	Light grey	■ ■ ■	Black		32	16	Orange	■ ■ ■ ■ ■	Black	
	15	8	White	■ ■ ■	Red		33	17	Light Grey	■ ■ ■ ■ ■	Red	
	16	8	White	■ ■ ■	Black		34	17	Light Grey	■ ■ ■ ■ ■	Black	
	17	9	Yellow	■ ■ ■	Red							
	18	9	Yellow	■ ■ ■	Black							

Model Selection

LEY

LEYG

LEYG

LEYG

LECA6
LECP6

LEC-G

LECP1

LECPA

JXC□1

JXC7□□□□□□

JXC7□□□□□□

JXC7□□□□□□

LEY

LEYG

LECS□

LECS-T

LECY□

Specific Product Precautions

Options

Regeneration option (LECS□ common)

LEC-MR-RB-12

Regeneration option type

032	Allowable regenerative power 30 W
12	Allowable regenerative power 100 W

* Confirm regeneration option to be used in "Model Selection".

LEC-MR-RB-032

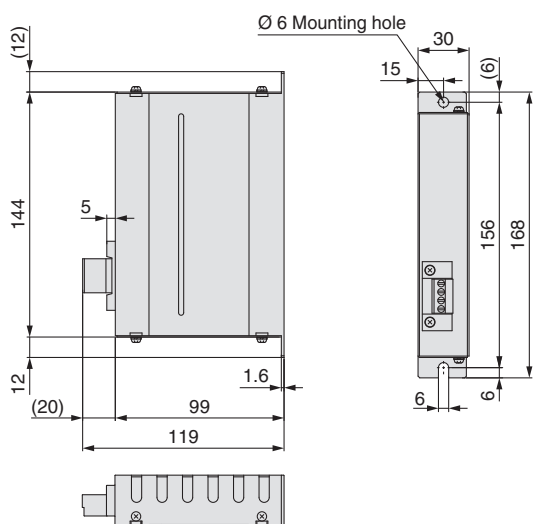

LEC-MR-RB-12

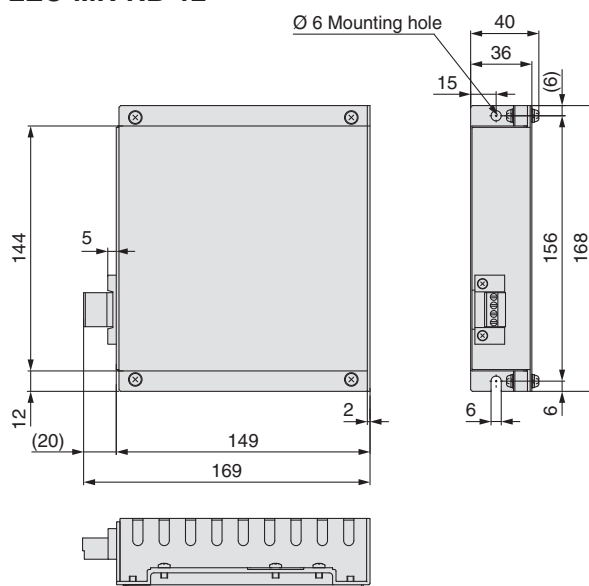

Weight

Model	Weight [kg]
LEC-MR-RB-032	0.5

* MR-RB032 manufactured by Mitsubishi Electric Corporation.

Weight

Model	Weight [kg]
LEC-MR-RB-12	1.1

* MR-RB12 manufactured by Mitsubishi Electric Corporation.

Options

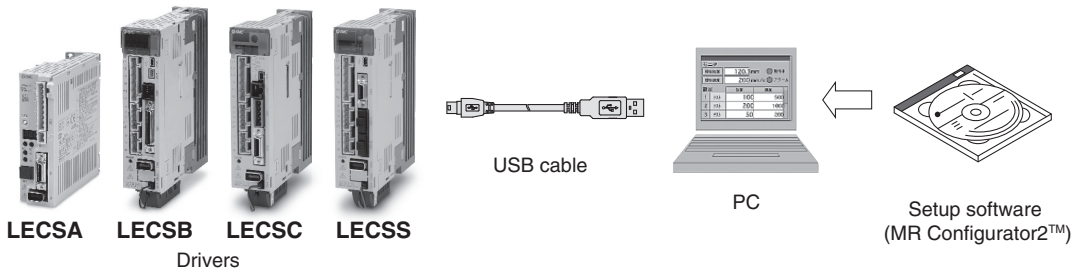

Setup software (MR Configurator2™) (LECSA, LECSB, LECS, LECS common)

LEC-MRC2 **E**

● Display language

—	Japanese version
E	English version
C	Chinese version

* SW1DNC-MRC2-□ manufactured by Mitsubishi Electric Corporation. Refer to Mitsubishi Electric Corporation's website for operating environment and version upgrade information. MR Configurator2™ is a registered trademark or trademark of Mitsubishi Electric Corporation.

Adjustment, waveform display, diagnostics, parameter read/write, and test operation can be performed upon a PC.

Compatible PC

When using setup software (MR Configurator2™), use an IBM PC/AT compatible PC that meets the following operating conditions.

Hardware Requirements

Equipment		Setup software (MR Configurator2™) LEC-MRC2 □
Note 1) 2) 3) 4) 5) 6) 7) 9) PC	OS	Microsoft® Windows®8 Enterprise Operating System Microsoft® Windows®8 Pro Operating System Microsoft® Windows®8 Operating System Microsoft® Windows®7 Enterprise Operating System Microsoft® Windows®7 Ultimate Operating System Microsoft® Windows®7 Professional Operating System Microsoft® Windows®7 Home Premium Operating System Microsoft® Windows®7 Starter Operating System Microsoft® Windows Vista® Enterprise Operating System Microsoft® Windows Vista® Ultimate Operating System Microsoft® Windows Vista® Business Operating System Microsoft® Windows Vista® Home Premium Operating System Microsoft® Windows Vista® Home Basic Operating System Microsoft® Windows®XP Professional Operating System, Service Pack 2 or later Microsoft® Windows®XP Home Edition Operating System, Service Pack 2 or later Microsoft® Windows®2000 Professional Operating System, Service Pack 4 or later
	Available HD space	1 GB or more
	Communication interface	Use USB port.
Display	Resolution 1024 x 768 or more Must be capable of high color (16-bit) display. The connectable with the above PC	
Keyboard	The connectable with the above PC	
Mouse	The connectable with the above PC	
Printer	The connectable with the above PC	
USB cable Note 8)	LEC-MR-J3USB	

- Note 1) Before using a PC for setting LECSA point table method/program operation method, upgrade to version 1.18U (Japanese version)/version 1.19V (English version) or later. Refer to Mitsubishi Electric Corporation's website for version upgrade information.
- Note 2) Windows® and Windows Vista® are registered trademarks of Microsoft Corporation in the United States and other countries.
- Note 3) On some PCs, setup software (MR Configurator2™) may not run properly.
- Note 4) When Windows®XP or later is used, the following functions cannot be used.
- Windows Program Compatibility mode
 - Fast User Switching
 - Remote Desktop
 - Large Fonts Mode (Display property)
 - DPI settings other than 96 DPI (Display property)
 - 64-bit OSs are not supported, except for Microsoft® Windows®7 or later.
- Note 5) When Windows®7 is used, the following functions cannot be used.
- Windows XP Mode
 - Windows Touch
- Note 6) When using this software with Windows Vista® or later, log in as a user having USER authority or higher.
- Note 7) When Windows®8 is used, the following functions cannot be used.
- Hyper-V
 - Modern UI style
- Note 8) Order USB cable separately.
- Note 9) Using a PC for setting Windows®8.1, upgrade to version 1.25B or later. Refer to Mitsubishi Electric Corporation's website for version upgrade information.

Setup Software Compatible Driver

Compatible driver	Setup software
	MR Configurator2™ LEC-MRC2 □
LECSA	○
LECSB	○
LECS	○
LECSS □-S □	○
LECSS2-T □	○

USB cable (3 m)

LEC-MR-J3USB

* MR-J3USBCBL3M manufactured by Mitsubishi Electric Corporation.

Cable for connecting PC and driver when using the setup software (MR Configurator2™).

Do not use any cable other than this cable.

Battery (only for LECSB, LECS or LECS)

LEC-MR-J3BAT

* MR-J3BAT manufactured by Mitsubishi Electric Corporation.

Battery for replacement.

Absolute position data is maintained by installing the battery to the driver.



AC Servo Motor Driver

Absolute Type



Series LECSS-T

(SSCNET III/H Type)



How to Order

Driver

LECSS2-T5

Driver type

S	SSCNET III/H type (For absolute encoder)
---	---

Power supply voltage

2	200 to 240 VAC, 50/60 Hz
---	--------------------------

Compatible motor type

Symbol	Type	Capacity	Encoder
T5	AC servo motor (T6)	100 W	Absolute
T7	AC servo motor (T7)	200 W	
T8	AC servo motor (T8)	400 W	

Dimensions

LECSS2-T□

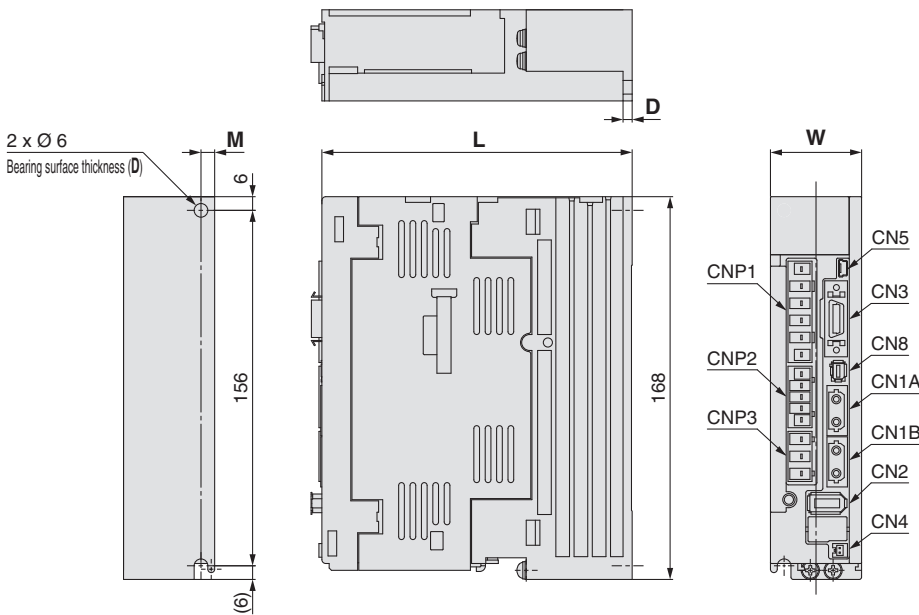

Connector name	Description
CN1A	Front axis connector for SSCNET III/H
CN1B	Rear axis connector for SSCNET III/H
CN2	Encoder connector
CN3	I/O signal connector
CN4	Battery connector
CN5	USB communication connector
CN8	STO input signal connector
CNP1	Main circuit power supply connector
CNP2	Control circuit power supply connector
CNP3	Servo motor power connector

Dimensions

Model	[mm]			
	W	L	D	M
LECSS2-T5	40	135	4	6
LECSS2-T7		170	5	
LECSS2-T8				

Specifications

Model		LECSS2-T5	LECSS2-T7	LECSS2-T8
Compatible motor capacity [W]		100	200	400
Compatible encoder		Absolute 22-bit encoder (Resolution: 4194304 p/rev)		
Main power supply	Power voltage [V]	Three phase 200 to 240 VAC (50/60 Hz), Single phase 200 to 240 VAC (50/60 Hz)		
	Allowable voltage fluctuation [V]	Three phase 170 to 264 VAC (50/60 Hz), Single phase 170 to 264 VAC (50/60 Hz)		
	Rated current [A]	0.9	1.5	2.6
Control power supply	Control power supply voltage [V]	Single phase 200 to 240 VAC (50/60 Hz)		
	Allowable voltage fluctuation [V]	Single phase 170 to 264 VAC		
	Rated current [A]	0.2		
Applicable Fieldbus protocol		SSCNET III/H (High-speed optical communication)		
Communication function		USB communication		
Operating temperature range [°C]		0 to 55 (No freezing)		
Operating humidity range [%RH]		90 or less (No condensation)		
Storage temperature range [°C]		-20 to 65 (No freezing)		
Storage humidity range [%RH]		90 or less (No condensation)		
Insulation resistance [MΩ]		Between the housing and SG: 10 (500 VDC)		
Weight [g]		800		1000

Power Supply Wiring Example: LECSS2-T□

For single phase 200 VAC

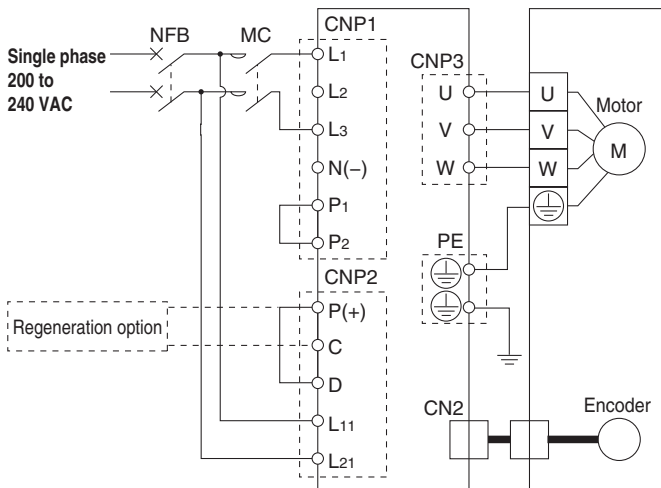

For three phase 200 VAC

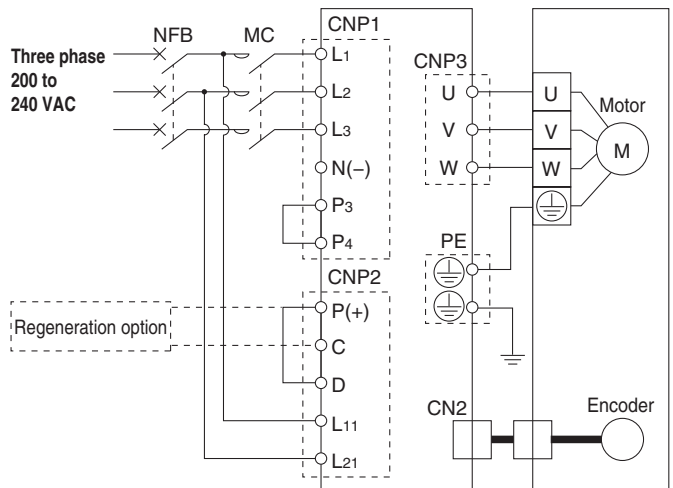

Note) For single phase 200 to 240 VAC, power supply should be connected to L1 and L3 terminals, with nothing connected to L2.

Main Circuit Power Supply Connector: CNP1 * Accessory

Terminal name	Function	Details
L1	Main circuit power supply	Connect the main circuit power supply. LECSS2: Single phase 200 to 240 VAC, 50/60 Hz Connection terminal: L1,L3 Three phase 200 to 240 VAC, 50/60 Hz Connection terminal: L1,L2,L3
L2		
L3		
N(-)	Do not connect.	
P3	Connect between P3 and P4. (Connected at time of shipping.)	
P4		

Control Circuit Power Supply Connector: CNP2 * Accessory

Terminal name	Function	Details
P(+)	Regeneration option	Connect between P(+) and D. (Connected at time of shipping.) * If regeneration option is required for "Model Selection", connect to this terminal.
C		
D		
L11	Control circuit power supply	Connect the control circuit power supply. LECSS2: Single phase 200 to 240 VAC, 50/60 Hz Connection terminal: L11,L21 Three phase 200 to 240 VAC, 50/60 Hz Connection terminal: L11,L21
L21		

Motor Connector: CNP3 * Accessory

Terminal name	Function	Details
U	Servo motor power (U)	Connect to motor cable (U, V, W).
V	Servo motor power [V]	
W	Servo motor power [W]	

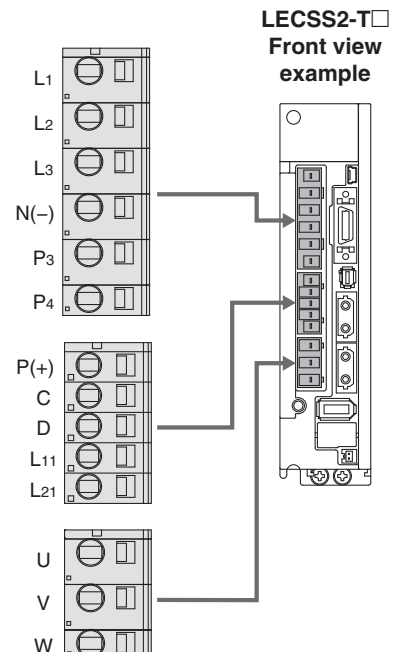

Series LECSS-T

Control Signal Wiring Example: LECSS2-T□

For sink I/O interface

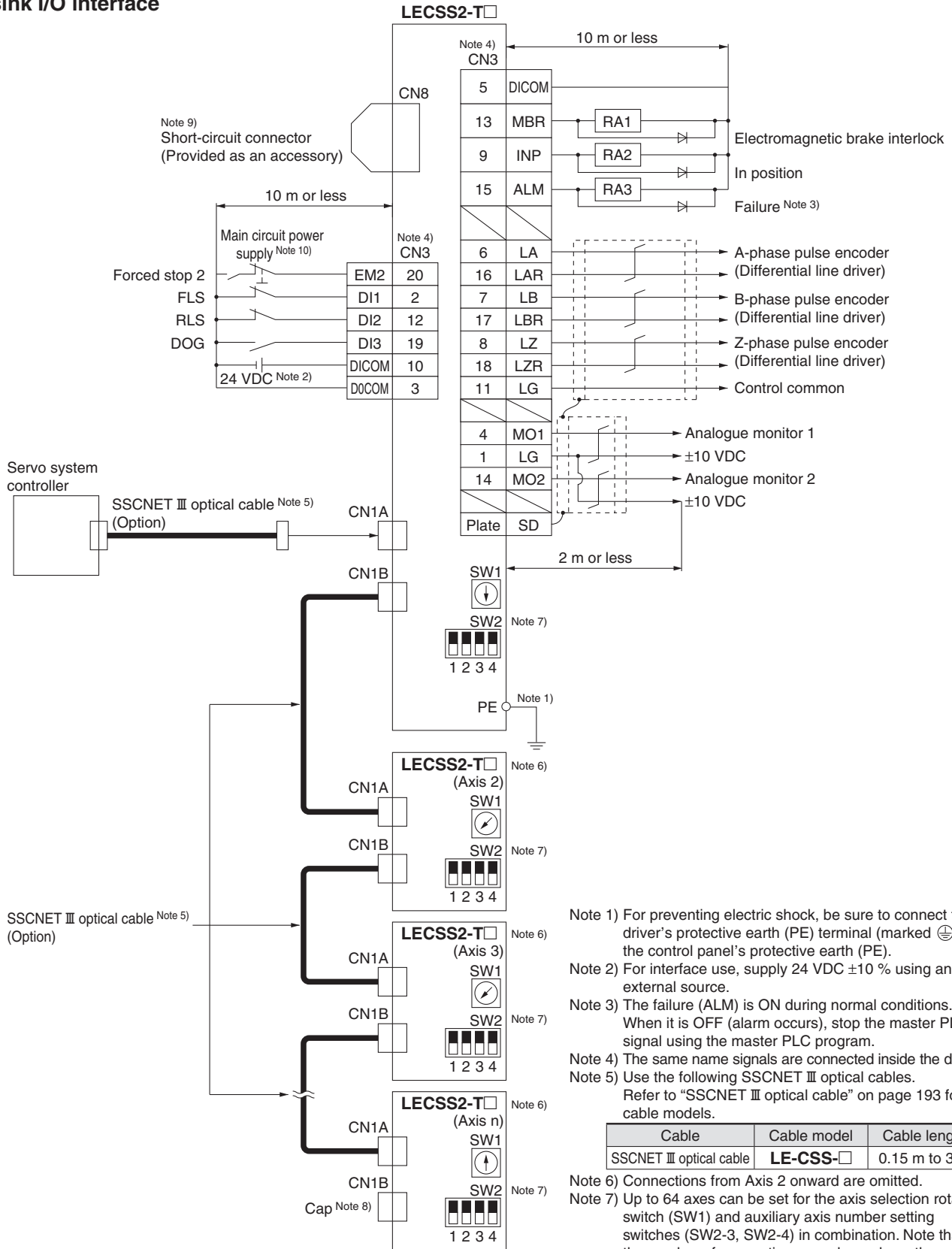

- Note 1) For preventing electric shock, be sure to connect the driver's protective earth (PE) terminal (marked ⊕) to the control panel's protective earth (PE).
- Note 2) For interface use, supply 24 VDC $\pm 10\%$ using an external source.
- Note 3) The failure (ALM) is ON during normal conditions. When it is OFF (alarm occurs), stop the master PLC signal using the master PLC program.
- Note 4) The same name signals are connected inside the driver.
- Note 5) Use the following SSCNET III optical cables. Refer to "SSCNET III optical cable" on page 193 for cable models.

Cable	Cable model	Cable length
SSCNET III optical cable	LE-CSS-□	0.15 m to 3 m

- Note 6) Connections from Axis 2 onward are omitted.
- Note 7) Up to 64 axes can be set for the axis selection rotary switch (SW1) and auxiliary axis number setting switches (SW2-3, SW2-4) in combination. Note that the number of connection axes depends on the specifications of the master PLC.
- Note 8) Be sure to place a cap on unused CN1A/CN1B.
- Note 9) When not using the STO function, use the driver with the short-circuit connector (provided as an accessory) inserted.
- Note 10) Configure a circuit to turn off EM2 when the main circuit power is turned off to prevent an unexpected restart of the driver.

Options

Motor cable, Lock cable, Encoder cable (LECS□ common)

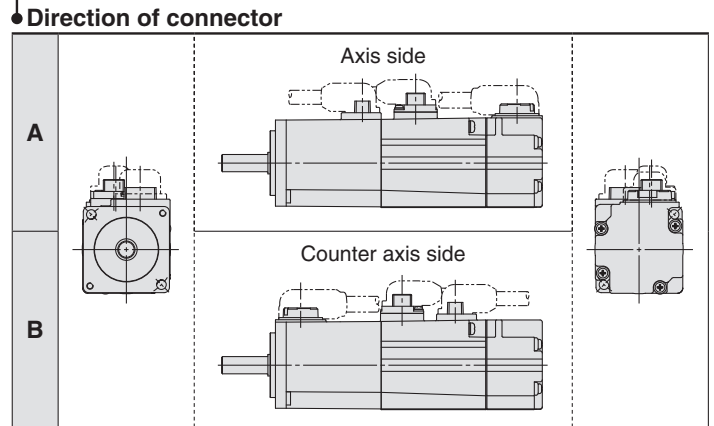
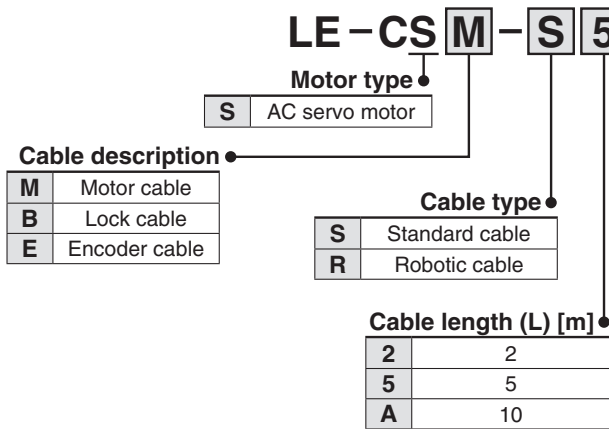

LE-CSM-□□: Motor cable

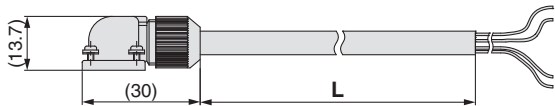

LE-CSB-□□: Lock cable

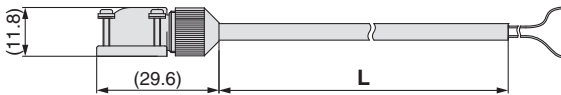

LE-CSE-□□: Encoder cable

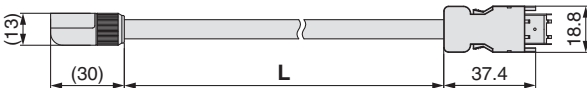

Product no.	∅ D
LEC-CSM-S□A	6.2
LEC-CSM-S□B	
LEC-CSM-R□A	5.7
LEC-CSM-R□B	
LEC-CSB-S□A	4.7
LEC-CSB-S□B	
LEC-CSB-R□A	4.5
LEC-CSB-R□B	

I/O connector (Without cable, Connector only)

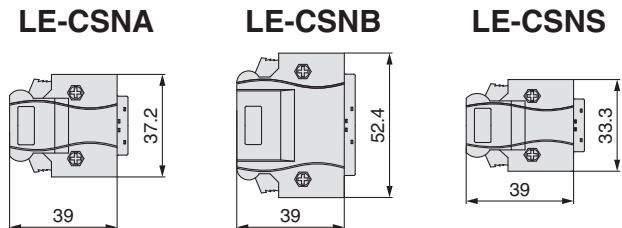
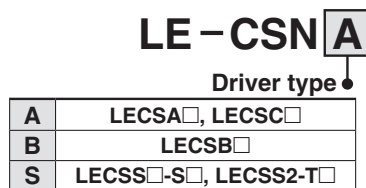

* LE-CSNA: 10126-3000PE (connector)/10326-52F0-008 (shell kit) manufactured by 3M or equivalent item.
 LE-CSNB: 10150-3000PE (connector)/10350-52F0-008 (shell kit) manufactured by 3M or equivalent item.
 LE-CSNS: 10120-3000PE (connector)/10320-52F0-008 (shell kit) manufactured by 3M or equivalent item.
 * Conductor size: AWG24 to 30

Model Selection

LEY

LEYG

LECA6
LECP6

LEC-G

LECP1

LECPA

JXC□1

JXC7303/92/93

AC Servo Motor

LEY

LEYG

LECS□

LECS-T

LECY□

Specific Product Precautions

Series LECSS-T

Options

SSCNET III optical cable (LECSS□-S□, LECSS2-T□)

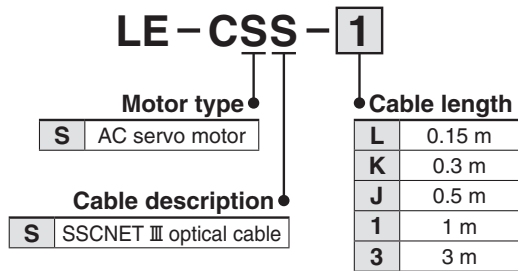

* LE-CSS-□ is MR-J3BUS□M manufactured by Mitsubishi Electric Corporation.

I/O cable

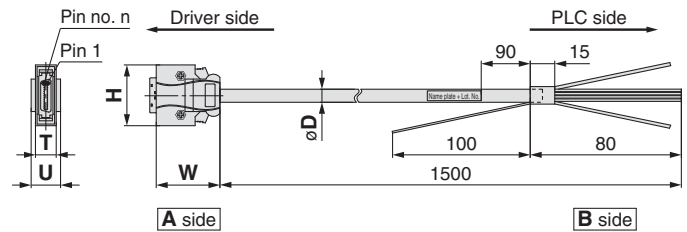
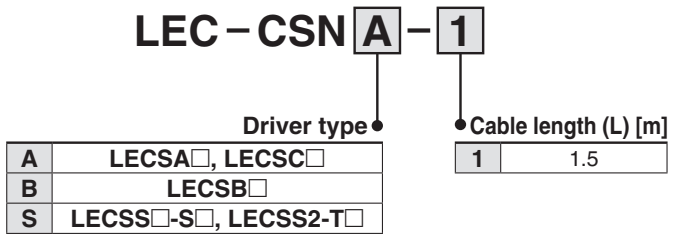

* LEC-CSNA-1: 10126-3000PE (connector)/10326-52F0-008 (shell kit) manufactured by Sumitomo 3M Limited or equivalent item.
 LEC-CSNB-1: 10150-3000PE (connector)/10350-52F0-008 (shell kit) manufactured by Sumitomo 3M Limited or equivalent item.
 LEC-CSNS-1: 10120-3000PE (connector)/10320-52F0-008 (shell kit) manufactured by Sumitomo 3M Limited or equivalent item.
 * Conductor size: AWG24

Cable O.D.

Product no.	Ø D
LEC-CSNA-1	11.1
LEC-CSNB-1	13.8
LEC-CSNS-1	9.1

Dimensions/Pin No.

Product no.	W	H	T	U	Pin no. n
LEC-CSNA-1	39	37.2	12.7	14	14
LEC-CSNB-1		52.4		18	26
LEC-CSNS-1		33.3		14	21

Wiring

LEC-CSNA-1: Pin no. 1 to 26

LEC-CSNB-1: Pin no. 1 to 50

LEC-CSNS-1: Pin no. 1 to 20

Connector pin no.	Pair no. of wire	Insulation colour	Dot mark	Dot colour
1	1	Orange	■	Red
2			■	Black
3	2	Light Grey	■	Red
4			■	Black
5	3	White	■	Red
6			■	Black
7	4	Yellow	■	Red
8			■	Black
9	5	Pink	■	Red
10			■	Black
11	6	Orange	■ ■	Red
12			■ ■	Black
13	7	Light Grey	■ ■	Red
14			■ ■	Black
15	8	White	■ ■	Red
16			■ ■	Black
17	9	Yellow	■ ■	Red
18			■ ■	Black

Connector pin no.	Pair no. of wire	Insulation colour	Dot mark	Dot colour
19	10	Pink	■ ■	Red
20			■ ■	Black
21	11	Orange	■ ■ ■	Red
22			■ ■ ■	Black
23	12	Light Grey	■ ■ ■	Red
24			■ ■ ■	Black
25	13	White	■ ■ ■	Red
26			■ ■ ■	Black
27	14	Yellow	■ ■ ■	Red
28			■ ■ ■	Black
29	15	Pink	■ ■ ■	Red
30			■ ■ ■	Black
31	16	Orange	■ ■ ■ ■	Red
32			■ ■ ■ ■	Black
33	17	Light Grey	■ ■ ■ ■	Red
34			■ ■ ■ ■	Black

Connector pin no.	Pair no. of wire	Insulation colour	Dot mark	Dot colour
35	18	White	■ ■ ■ ■	Red
36			■ ■ ■ ■	Black
37	19	Yellow	■ ■ ■ ■	Red
38			■ ■ ■ ■	Black
39	20	Pink	■ ■ ■ ■	Red
40			■ ■ ■ ■	Black
41	21	Orange	■ ■ ■ ■ ■	Red
42			■ ■ ■ ■ ■	Black
43	22	Light Grey	■ ■ ■ ■ ■	Red
44			■ ■ ■ ■ ■	Black
45	23	White	■ ■ ■ ■ ■	Red
46			■ ■ ■ ■ ■	Black
47	24	Yellow	■ ■ ■ ■ ■	Red
48			■ ■ ■ ■ ■	Black
49	25	Pink	■ ■ ■ ■ ■	Red
50			■ ■ ■ ■ ■	Black

Options

Regeneration option (LECS□ common)

LEC-MR-RB-12

Regeneration option type

032	Allowable regenerative power 30 W
12	Allowable regenerative power 100 W

* Confirm regeneration option to be used in "Model Selection".

LEC-MR-RB-032

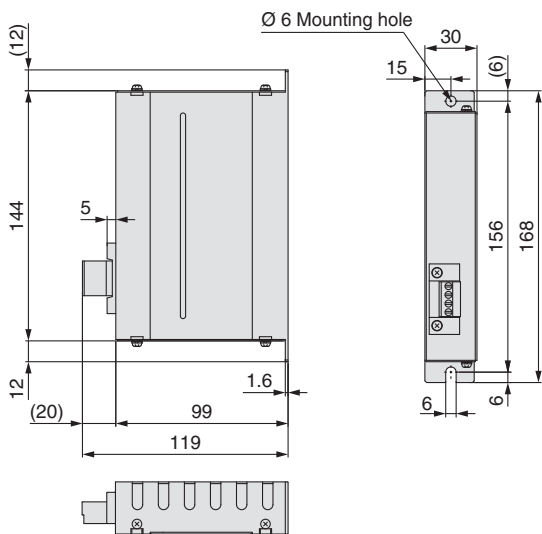

Weight

Model	Weight [kg]
LEC-MR-RB-032	0.5

* MR-RB032 manufactured by Mitsubishi Electric Corporation.

LEC-MR-RB-12

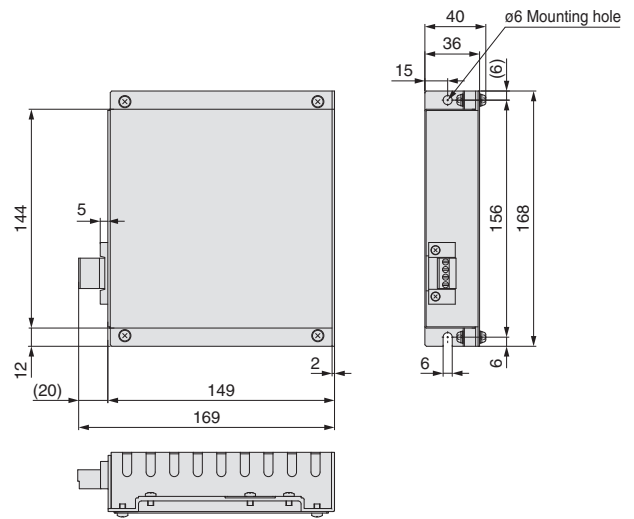

Weight

Model	Weight [kg]
LEC-MR-RB-12	1.1

* MR-RB12 manufactured by Mitsubishi Electric Corporation.

Model Selection

Servo Motor (24 VDC)/Step Motor (Servo/24 VDC)
LEYG
LEY

LECA6
LECP6

LEC-G

LECP1

LECPA

JXC□1

JXC73/83/92/93

AC Servo Motor
LEY

LEYG

LECS□

LECSS-T

LECY□

Specific Product Precautions

Series LECSS-T

Options

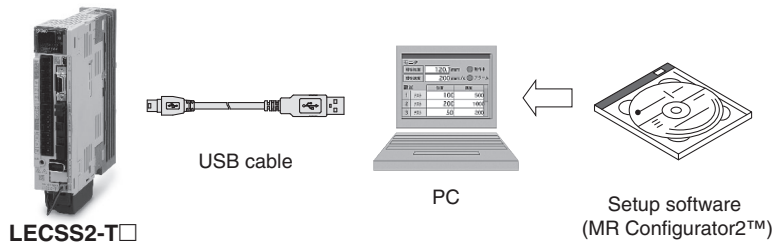

Setup software (MR Configurator2™) (LECSA, LECSB, LECSA, LECSS common)

LEC-MRC2 E

Display language

—	Japanese version
E	English version
C	Chinese version

* SW1DNC-MRC2□ manufactured by Mitsubishi Electric Corporation. Refer to Mitsubishi Electric Corporation's website for operating environment and version upgrade information. MR Configurator2™ is a registered trademark or trademark of Mitsubishi Electric Corporation.

Adjustment, waveform display, diagnostics, parameter read/write, and test operation can be performed upon a PC.

Compatible PC

When using setup software (MR Configurator2™), use an IBM PC/AT compatible PC that meets the following operating conditions.

Hardware Requirements

Equipment		Setup software (MR Configurator2™) LEC-MRC2□	
Note 1) 2) 3) 4) 5) 6) 7) 9) PC	OS	Microsoft® Windows®8.1 Enterprise Operating System Microsoft® Windows®8.1 Pro Operating System Microsoft® Windows®8.1 Operating System Microsoft® Windows®8 Enterprise Operating System Microsoft® Windows®8 Pro Operating System Microsoft® Windows®8 Operating System Microsoft® Windows®7 Ultimate Operating System Microsoft® Windows®7 Enterprise Operating System Microsoft® Windows®7 Professional Operating System Microsoft® Windows®7 Home Premium Operating System Microsoft® Windows®7 Starter Operating System Microsoft® Windows Vista® Ultimate Operating System Microsoft® Windows Vista® Enterprise Operating System Microsoft® Windows Vista® Business Operating System Microsoft® Windows Vista® Home Premium Operating System Microsoft® Windows Vista® Home Basic Operating System Microsoft® Windows®XP Professional Operating System, Service Pack 2 or later Microsoft® Windows®XP Home Edition Operating System, Service Pack 2 or later	Note 1) Before using a PC for setting LECSA point table method/program method, upgrade to version 1.18U (Japanese version)/version 1.19V (English version). Refer to Mitsubishi Electric Corporation's website for version upgrade information. Note 2) Windows and Windows Vista are registered trademarks of Microsoft Corporation in the United States and other countries. Note 3) On some PCs, MR Configurator2 may not run properly. Note 4) When Windows®XP or later is used, the following functions cannot be used. · Windows Program Compatibility mode · Fast User Switching · Remote Desktop · Large Fonts Mode (Display property) · DPI settings other than 96 DPI (Display property) For 64-bit operating system, this software is compatible with Windows®7 and Windows®8. Note 5) When Windows®7 is used, the following functions cannot be used. · Windows XP Mode · Windows Touch Note 6) When using this software with Windows Vista® or later, log in as a user having USER authority or higher. Note 7) When Windows®8 is used, the following functions cannot be used. · Hyper-V · Modern UI style Note 8) Order USB cable separately. Note 9) Using a PC for setting Windows®8.1, upgrade to version 1.25B or later. Refer to Mitsubishi Electric Corporation's website for version upgrade information.
	Available HD space	1 GB or more	
	Communication interface	Use USB port.	
Display	Resolution 1024 x 768 or more Must be capable of high color (16-bit) display. The connectable with the above PC		
Keyboard	The connectable with the above PC		
Mouse	The connectable with the above PC		
Printer	The connectable with the above PC		
USB cable <small>Note 8)</small>	LEC-MR-J3USB		

Setup Software Compatible Driver

Compatible driver	Setup software
	MR Configurator2™
	LEC-MRC2□
LECSA	○
LECSB	○
LECSA	○
LECSS□-S□	○
LECSS2-T□	○

Options

Battery (only for LECSS2-T□)

LEC – MR – BAT6V1SET

* MR-BAT6V1SET manufactured by Mitsubishi Electric Corporation.

Battery for replacement.

Absolute position data is maintained by installing the battery to the driver.

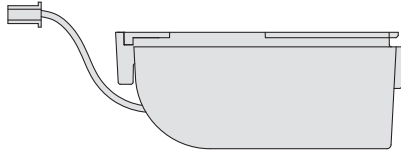

Note) The LEC-MR-BAT6V1SET is an assembled battery that uses lithium metal battery 2CR17335A. When transporting lithium metal batteries and devices with built-in lithium metal batteries by a method subject to UN regulations, it is necessary to apply measures according to the regulations stipulated in the United Nations Recommendations on the Transport of Dangerous Goods, the Technical Instructions (ICAO-TI) of the International Civil Aviation Organization (ICAO), and the International Maritime Dangerous Goods Code (IMDG CODE) of the International Maritime Organization (IMO). If a customer is transporting products such as shown above, it is necessary to confirm the latest regulations, or the laws and regulations of the country of transport on your own, in order to apply the proper measures. Please contact SMC sales representative for details.

USB cable (3 m)

LEC – MR – J3USB

* MR-J3USB manufactured by Mitsubishi Electric Corporation.

Cable for connecting PC and driver when using the setup software (MR Configurator2™).

Do not use any cable other than this cable.

STO cable (3 m)

LEC – MR – D05UDL3M

* MR-D05UDL3M manufactured by Mitsubishi Electric Corporation.

Cable for connecting the driver and device, when using the safety function.

Do not use any cable other than this cable.

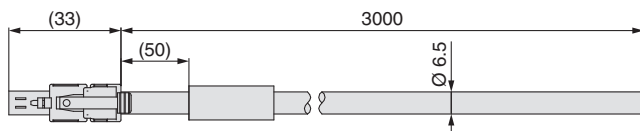

Model Selection

LECY

LEYG

LECA6
LECP6

LEC-G

LECP1

LECPA

JXC□1

JXC7303/02/03

LECY

LEYG

LECS□

LECSS-T

LECY□

Specific Product Precautions



Specific Product Precautions 1

Be sure to read before handling. Refer to back cover for Safety Instructions.

For Electric Actuator Precautions, refer to “Handling Precautions for SMC Products” and the Operation Manual on SMC website, <http://www.smc.eu>

Design/Selection

Warning

1. Use the specified voltage.

If the applied voltage is higher than the specified voltage, malfunction and damage to the driver may result. If the applied voltage is lower than the specified voltage, there is a possibility that the load cannot be moved due to internal voltage drop. Check the operating voltage prior to start. Also, confirm that the operating voltage does not drop below the specified voltage during operation.

2. Do not use the products outside the specifications.

Otherwise, fire, malfunction or damage to the driver/actuator can result. Check the specifications prior to use.

3. Install an emergency stop circuit.

Install an emergency stop outside the enclosure in easy reach to the operator so that the operator can stop the system operation immediately and intercept the power supply.

4. To prevent danger and damage due to a breakdown or malfunction of these products, which may occur at a certain probability, a backup system should be arranged in advance by using a multiple-layered structure or by making a fail-safe equipment design, etc.

5. If there is a risk of fire or personal injury due to abnormal heat generation, sparking, smoke generated by the product, etc., cut off the power supply from this product and the system immediately.

6. The parameters of the driver are set to initial values. Please change parameters according to the specifications of the customer's equipment before use. Refer to the operation manual for details of parameters.

Handling

Warning

1. Never touch the inside of the driver and its peripheral devices.

Otherwise, electric shock or failure can result.

2. Do not operate or set up this equipment with wet hands.

Otherwise, electric shock can result.

3. Do not use a product that is damaged or missing any components.

Electric shock, fire or injury can result.

4. Use only the specified combination between the electric actuator and driver.

Otherwise, it may cause damage to the driver or to the other equipment.

5. Be careful not to touch, get caught or hit by the workpiece while the actuator is moving.

An injury can result.

6. Do not connect the power supply or power up the product until it is confirmed that the workpiece can be moved safely within the area that can be reached by the workpiece.

Otherwise, the movement of the workpiece may cause an accident.

7. Do not touch the product when it is energized and for some time after the power has been disconnected, as it is very hot.

Otherwise, it may cause burns due to the high temperature.

8. Check the voltage using a tester at least 5 minutes after power-off when performing installation, wiring and maintenance.

Otherwise, electric shock, fire or injury can result.

Handling

Warning

9. Static electricity may cause a malfunction or damage the driver. Do not touch the driver while power is supplied to it.

Take sufficient safety measures to eliminate static electricity when it is necessary to touch the driver for maintenance.

10. Do not use the products in an area where they could be exposed to dust, metallic powder, machining chips or splashes of water, oil or chemicals.

Otherwise, a failure or malfunction can result.

11. Do not use the products in a magnetic field.

Otherwise, a malfunction or failure can result.

12. Do not use the products in an environment where flammable, explosive or corrosive gases, liquids or other substances are present.

Otherwise, fire, explosion or corrosion can result.

13. Avoid heat radiation from strong heat sources, such as direct sunlight or a hot furnace.

Otherwise, it will cause a failure to the driver or its peripheral devices.

14. Do not use the products in an environment with cyclic temperature changes.

Otherwise, it will cause a failure to the driver or its peripheral devices.

15. Do not use the products in an environment where surges are generated.

Devices (solenoid type lifters, high frequency induction furnaces, motors, etc.) that generate a large amount of surge around the product may lead to deterioration or damage to the internal circuits of the products. Avoid supplies of surge generation and crossed lines.

16. Do not install these products in a place subject to vibration and impact.

Otherwise, a malfunction or failure can result.

17. When a surge generating load such as a relay or solenoid valve is directly driven, use a product that incorporates a surge absorption element.

Mounting

Warning

1. Install the driver and its peripheral devices on fireproof material.

Direct installation on or near flammable material may cause fire.

2. Do not install these products in a place subject to vibration and impact.

Otherwise, a malfunction or failure can result.

3. The driver should be mounted on a vertical wall in a vertical direction. Also, do not cover the driver's suction/exhaust ports.

4. Install the driver and its peripheral devices on a flat surface.

If the mounting surface is not flat or uneven, excessive force may be applied to the housing and other parts resulting in a malfunction.



Series LECS

Specific Product Precautions 2

Be sure to read before handling. Refer to back cover for Safety Instructions.

For Electric Actuator Precautions, refer to “Handling Precautions for SMC Products” and the Operation Manual on SMC website, <http://www.smc.eu>

Power Supply

Caution

1. Use a power supply with low noise between lines and between power and ground.
In cases where noise is high, use an isolation transformer.
2. Take appropriate measures to prevent surges from lightning. Ground the surge absorber for lightning separately from the grounding of the driver and its peripheral devices.

Wiring

Warning

1. The driver will be damaged if a commercial power supply (100V/200V) is added to the driver's servo motor power (U, V, W). Be sure to check wiring such as wiring mistakes when the power supply is turned on.
2. Connect the ends of the U, V, W wires from the motor cable correctly to the phases (U, V, W) of the servo motor power. If these wires do not match up, it is unable to control the servo motor.

Grounding

Warning

1. For grounding actuator, connect the copper wire of the actuator to the driver's protective earth (PE) terminal and connect the copper wire of the driver to the earth via the control panel's protective earth (PE) terminal. Do not connect them directly to the control panel's protective earth (PE) terminal.

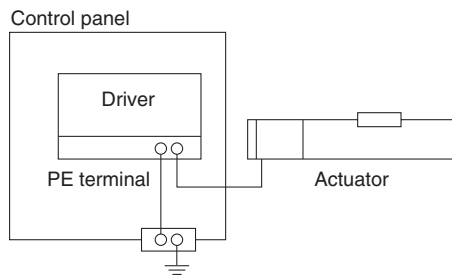

2. In the unlikely event that malfunction is caused by the ground, it may be disconnected.

Maintenance

Warning

1. Perform maintenance checks periodically.
Confirm wiring and screws are not loose.
Loose screws or wires may cause unexpected malfunction.
2. Conduct an appropriate functional inspection and test after completed maintenance.
In case of any abnormalities (if the actuator does not move or the equipment does not operate properly, etc.), stop the operation of the system.
Otherwise, unexpected malfunction may occur and safety cannot be assured.
Conduct a test of the emergency stop to confirm the safety of the equipment.
3. Do not disassemble, modify or repair the driver or its peripheral devices.
4. Do not put anything conductive or flammable inside the driver.
Otherwise, fire can result.
5. Do not conduct an insulation resistance test or insulation withstand voltage test.
6. Reserve sufficient space for maintenance.
Design the system so that it allows required space for maintenance.

Model Selection

Servo Motor (24 VDC) (Step Motor (Servo/24 VDC))
LEY
LEYG

LECA6
LECP6

LEC-G

LECP1

LECPA

JXC

JXC7/3/3/3/2/3/3

LEY

LEYG

LECS

LECS-T

LECY

Specific Product Precautions

AC Servo Motor Driver



Power supply voltage (V)
200 to 230 VAC

Motor capacity (W)
100/200/400

- Position control, speed control and torque control can be used.
- Control encoder: Absolute 20-bit encoder (Resolution: 1048576 p/rev)

MECHATROLINK-II Type

Series LECYM

- Applicable Fieldbus protocol: MECHATROLINK-II
- Number of connectable drivers: 30 units (Transmission distance: Max. 50 m in total)

Max. communication speed
10 Mbps

Min. communication cycle
250 μs



MECHATROLINK-III Type

Series LECYU

- Applicable Fieldbus protocol: MECHATROLINK-III
- Number of connectable drivers: 62 units (Transmission distance: Max. 75 m between stations)

Max. communication speed
100 Mbps

Min. communication cycle
125 μs



Compatible Actuators

Rod Type

Basic type
Series LEY

Secondary battery compatible
Dust/Drip proof compatible



Size	Pushing force [N]	Stroke [mm]
25	485	Up to 400
32	588	Up to 500
63	3343	Up to 800

In-line motor type
Series LEY□D

Secondary battery compatible
Dust/Drip proof compatible



Size	Pushing force [N]	Stroke [mm]
25	485	Up to 400
32	736	Up to 500
63	1910	Up to 800

Guide Rod Type

Guide rod type
Series LEYG

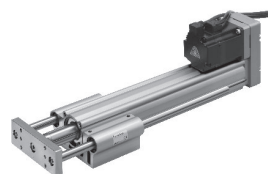

Size	Pushing force [N]	Stroke [mm]
25	485	Up to 300
32	588	

Guide rod type/
In-line motor type
Series LEYG□D



Size	Pushing force [N]	Stroke [mm]
25	485	Up to 300
32	736	

Series LECYM/LECYU



- Model Selection
- LEY
- LEYG
- LECA6
- LECP6
- LEC-G
- LECP1
- LECPA
- JXC□1
- JXC7303/92/93
- LEY
- LEYG
- LECS□
- LECS-T
- LECY□
- Specific Product Precautions

Series LECYM/LECYU

System Construction

Absolute encoder compatible Series LECYM

(MECHATROLINK-II type)

Provided by customer

Power supply

Single phase 200 to 230 VAC (50/60 Hz)
Three phase 200 to 230 VAC (50/60 Hz)

Provided by customer

External regenerative resistor

* If the external regenerative resistor is required, it should be provided by the customer. For selection of the external regenerative resistor, refer to the compatible actuator catalogue.

Motor cable

Standard cable	Robotic cable
LE-CYM-S□□-□	LE-CYM-R□□-□

Motor cable for lock option

Standard cable	Robotic cable
LE-CYB-S□□-□	LE-CYB-R□□-□

Electric actuator

Slider type
Series LEF

High rigidity slider type
Series LEJ

Rod type
Series LEY/LEYG

Encoder cable

Standard cable	Robotic cable
LE-CYE-S□□	LE-CYE-R□□

● Main circuit power supply connector (Accessory) Page 242

● Motor connector (Accessory) Page 242

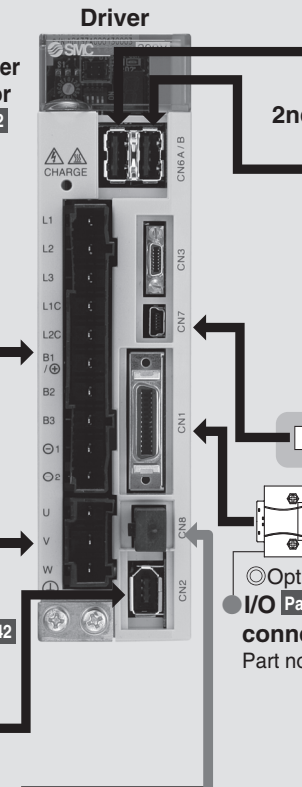

2nd driver

Provided by customer

PLC (Positioning unit/Motion controller)

Power supply for I/O signal 24 VDC



◎Option

● USB cable Page 248
Part no.: LEC-JZ-CVUSB

Setup software

(SigmaWin+™)
Please download it via our website.



PC

* Order USB cable (Part no.: LEC-JZ-CVUSB) separately to use this software.

◎Option
● I/O Page 246
connector
Part no.: LE-CYNA

● Cable for safety function device (3 m) Page 248
Part no.: LEC-JZ-CVSAF

Absolute encoder compatible Series LECYU

(MECHATROLINK-III type)

Provided by customer

Power supply

Single phase 200 to 230 VAC (50/60 Hz)
Three phase 200 to 230 VAC (50/60 Hz)

Provided by customer

External regenerative resistor

* If the external regenerative resistor is required, it should be provided by the customer. For selection of the external regenerative resistor, refer to the compatible actuator catalogue.

Motor cable

Standard cable	Robotic cable
LE-CYM-S□□-□	LE-CYM-R□□-□

Motor cable for lock option

Standard cable	Robotic cable
LE-CYB-S□□-□	LE-CYB-R□□-□

Electric actuator

Slider type
Series LEF

High rigidity slider type
Series LEJ

Rod type
Series LEY/LEYG

Encoder cable

Standard cable	Robotic cable
LE-CYE-S□□	LE-CYE-R□□

● Main circuit power supply connector (Accessory) Page 242

● Motor connector (Accessory) Page 242

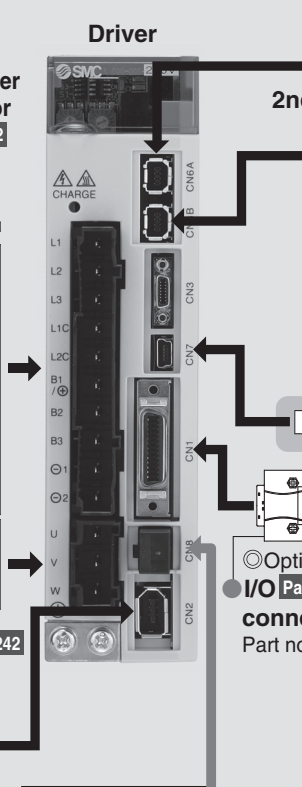

2nd driver

Provided by customer

PLC (Positioning unit/Motion controller)

Power supply for I/O signal 24 VDC



◎Option

● USB cable Page 248
Part no.: LEC-JZ-CVUSB

Setup software

(SigmaWin+™)
Please download it via our website.



PC

* Order USB cable (Part no.: LEC-JZ-CVUSB) separately to use this software.

◎Option
● I/O Page 246
connector
Part no.: LE-CYNA

● Cable for safety function device (3 m) Page 248
Part no.: LEC-JZ-CVSAF

AC Servo Motor

Rod Type Series LEY

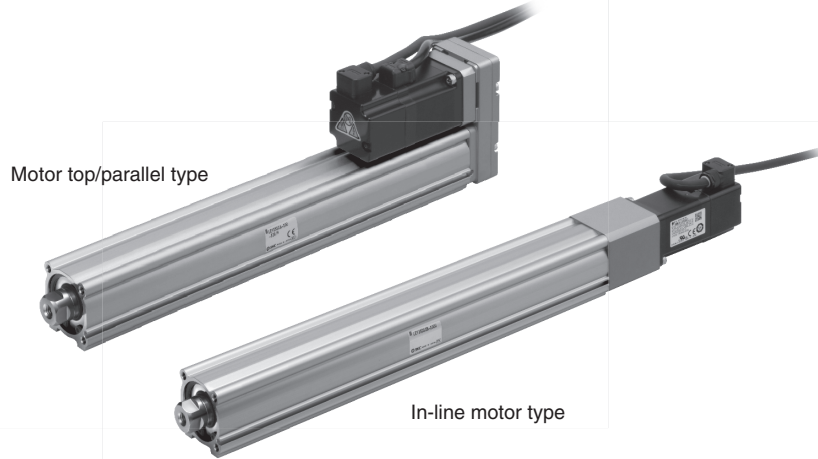

Guide Rod Type Series LEYG

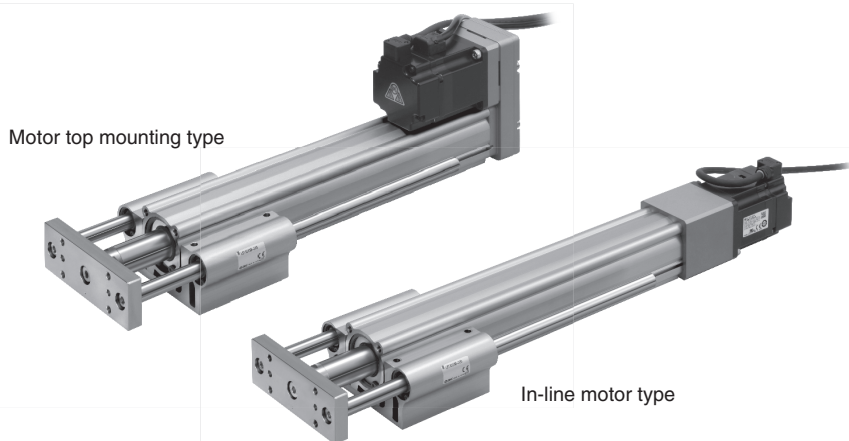

AC Servo Motor Driver Series LECYM/LECYU



Model Selection

Servo Motor (24 VDC)/Step Motor (Servo/24 VDC)

LEY

LEYG

LECA6
LECP6

LEC-G

LECP1

LECPA

JXC□1

JXC73/83/92/93

LEY

AC Servo Motor

LEYG

LECS□

LECS-T

LECY□

Specific Product Precautions

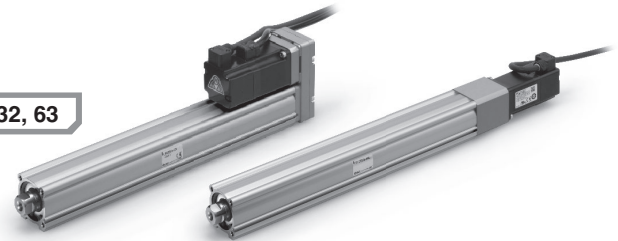

Selection Procedure

Positioning Control Selection Procedure



Selection Example

Operating conditions

- Workpiece weight: 16 [kg]
- Speed: 300 [mm/s]
- Acceleration/Deceleration: 5000 [mm/s²]
- Stroke: 300 [mm]
- Workpiece mounting condition: Vertical upward downward transfer

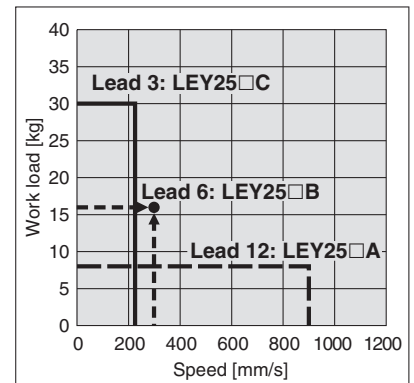

<Speed-Vertical work load graph> (LEY25□)

Step 1 Check the work load-speed. <Speed-Vertical work load graph>

Select the target model based on the workpiece weight and speed with reference to the <Speed-Vertical work load graph>.

Selection example) The **LEY25□B** is temporarily selected based on the graph shown on the right side.

* It is necessary to mount a guide outside the actuator when used for horizontal transfer. When selecting the target model, refer to pages 211 and 212 for the horizontal work load in the specifications, and page 234 for the precautions.

The regenerative resistor may be necessary. Refer to pages 205 and 206 for "Conditions for Regenerative Resistor (Guide)".

Step 2 Check the cycle time.

Calculate the cycle time using the following calculation method.

- Cycle time T can be found from the following equation.

$$T = T1 + T2 + T3 + T4 \text{ [s]}$$

- T1: Acceleration time and T3: Deceleration time can be obtained by the following equation.

$$T1 = V/a1 \text{ [s]} \quad T3 = V/a2 \text{ [s]}$$

- T2: Constant speed time can be found from the following equation.

$$T2 = \frac{L - 0.5 \cdot V \cdot (T1 + T3)}{V} \text{ [s]}$$

- T4: Settling time varies depending on the conditions such as motor types, load and in positioning of the step data. Therefore, please calculate the settling time with reference to the following value.

$$T4 = 0.05 \text{ [s]}$$

Calculation example)

T1 to T4 can be calculated as follows.

$$T1 = V/a1 = 300/5000 = 0.06 \text{ [s]}, \quad T3 = V/a2 = 300/5000 = 0.06 \text{ [s]}$$

$$T2 = \frac{L - 0.5 \cdot V \cdot (T1 + T3)}{V} = \frac{300 - 0.5 \cdot 300 \cdot (0.06 + 0.06)}{300} = 0.94 \text{ [s]}$$

$$T4 = 0.05 \text{ [s]}$$

Therefore, the cycle time can be obtained as follows.

$$T = T1 + T2 + T3 + T4 = 0.06 + 0.94 + 0.06 + 0.05 = 1.11 \text{ [s]}$$

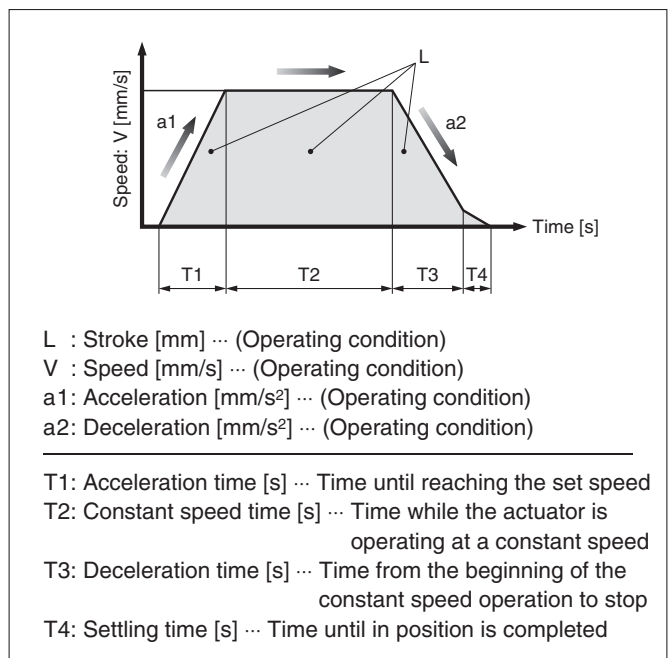

Based on the above calculation result, the LEY25□B-300 is selected.

Selection Procedure

Pushing Control Selection Procedure



* The duty ratio is a ratio at the time that can keep being pushed.

Selection Example

Operating conditions

- Mounting condition: Horizontal (pushing)
- Jig weight: 0.5 [kg]
- Pushing force: 255 [N]
- Duty ratio: 60 [%]
- Pushing speed: 35 [mm/s]
- Stroke: 300 [mm]

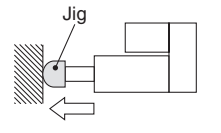

Step 1 Check the duty ratio.

<Conversion table of pushing force–duty ratio>

Select the [Pushing force] from the duty ratio with reference to the <Conversion table of pushing force–duty ratio>.

Selection example)

Based on the table below,

- Duty ratio: 60 [%]

Therefore, the set value of pushing force will be 90 [%].

<Conversion table of pushing force–duty ratio>

(LEY25/AC Servo motor)

Set value of pushing force [%]	Duty ratio [%]	Continuous pushing time [minute]
75 or less	100	—
90	60	1.5

* [Set value of pushing force] is one of the data input to the driver.

* [Continuous pushing time] is the time that the actuator can continuously keep pushing.

Step 2 Check the pushing force. <Force conversion graph>

Select the target model based on the torque limit/command value and pushing force with reference to the <Force conversion graph>.

Selection example)

Based on the graph shown on the right side,

- Torque limit/Command value: 90 [%]
- Pushing force: 255 [N]

Therefore, the **LEY25B** is temporarily selected.

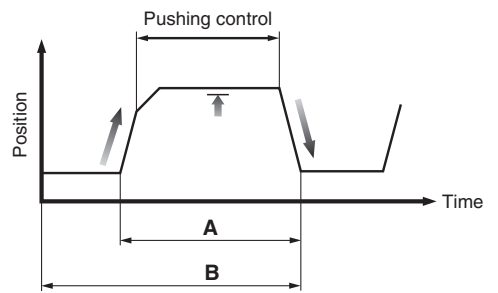

Duty ratio = A/B x 100 [%]

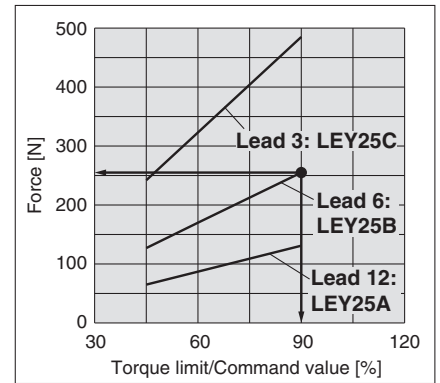

<Force conversion graph> (LEY25)

Step 3 Check the lateral load on the rod end.

<Graph of allowable lateral load on the rod end>

Confirm the allowable lateral load on the rod end of the actuator: LEY25B, which has been selected temporarily with reference to the <Graph of allowable lateral load on the rod end>.

Selection example)

Based on the graph shown on the right side,

- Jig weight: 0.5 [kg] ≈ 5 [N]
- Product stroke: 300 [mm]

Therefore, the lateral load on the rod end is in the allowable range.

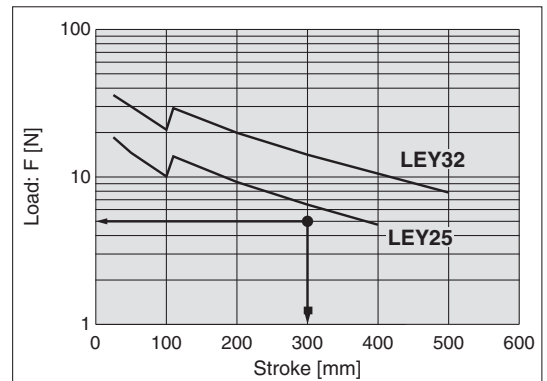

<Graph of allowable lateral load on the rod end>

Based on the above calculation result, the LEY25B-300 is selected.

- Model Selection
- LEY
- LEYG
- LECA6
- LECP6
- LEC-G
- LECP1
- LECPA
- JXC□1
- JXC7□□□□□□□□
- LEY
- LEYG
- LECS□
- LECS-T
- LECY□
- Specific Product Precautions

Series LEY/LEY-X5

Size 25, 32, 63

AC Servo Motor

Speed-Work Load Graph/Conditions for “Regenerative Resistor” (Guide)

LEY25□V6 (Motor mounting position: Top/Parallel, In-line)

Vertical

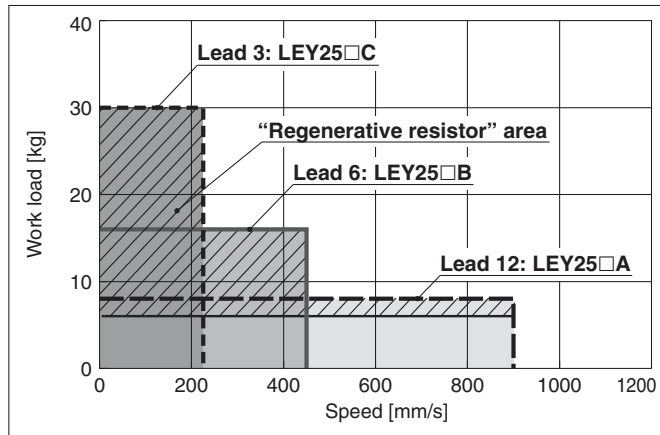

Horizontal

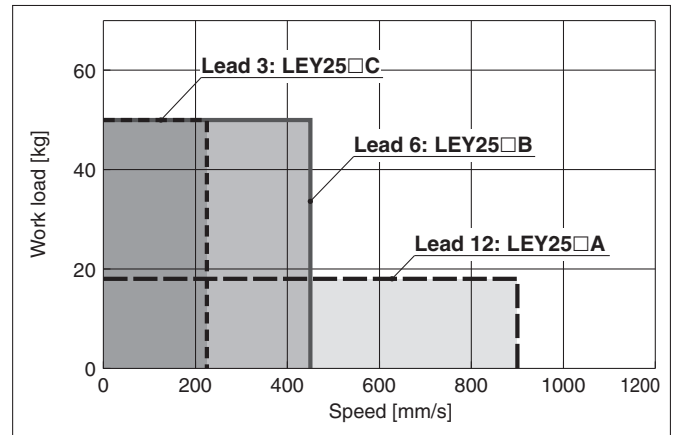

LEY32□V7 (Motor mounting position: Top/Parallel)

Vertical

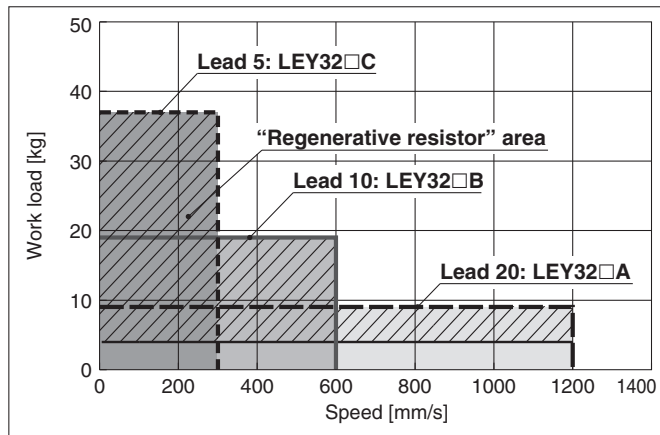

Horizontal

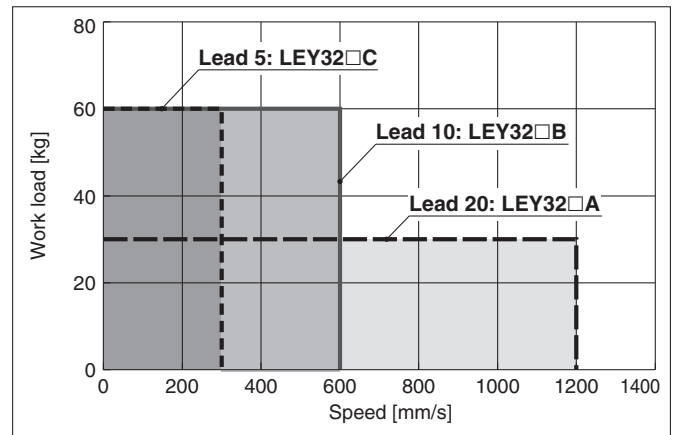

LEY32DV7 (Motor mounting position: In-line)

Vertical

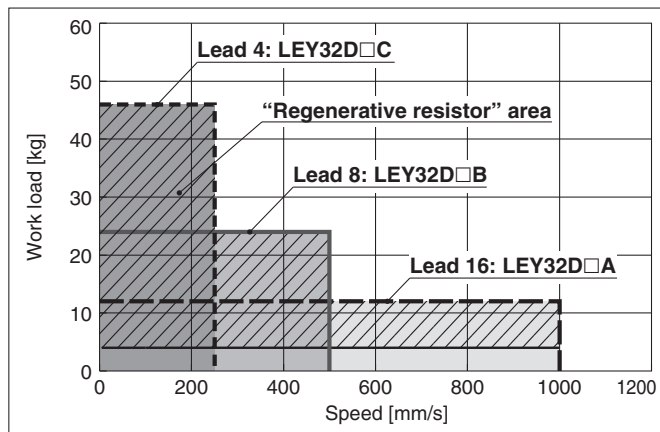

Horizontal

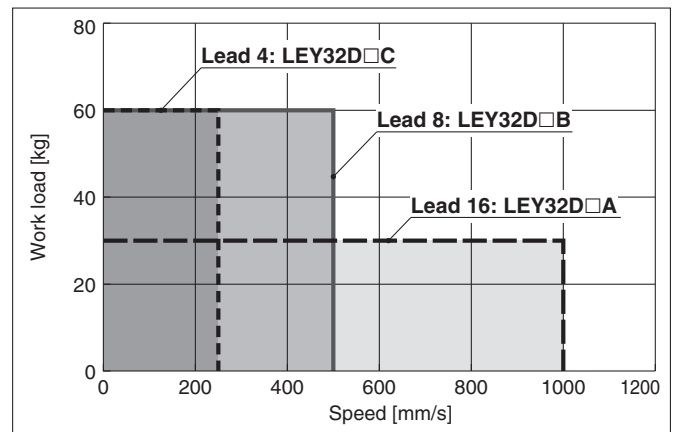

“Regenerative resistor” area

* When using the actuator in the “Regenerative resistor” area, download the “AC servo capacity selection program/SigmaJunmaSize+” from the SMC website. Then, calculate the necessary regenerative resistor capacity to prepare an appropriate external regenerative resistor.

* Regenerative resistor should be provided by the customer.

Applicable Motor/Driver

Model	Applicable model	
	Motor	Servopack (SMC driver)
LEY25□	SGMJV-01A3A	SGDV-R90A11□ (LECYM2-V5) SGDV-R90A21□ (LECYU2-V5)
LEY32□	SGMJV-02A3A	SGDV-1R6A11□ (LECYM2-V7) SGDV-1R6A21□ (LECYU2-V7)

Speed-Work Load Graph/Conditions for "Regenerative Resistor" (Guide)

LEY63□V8 (Motor mounting position: Top/Parallel, In-line)

Vertical

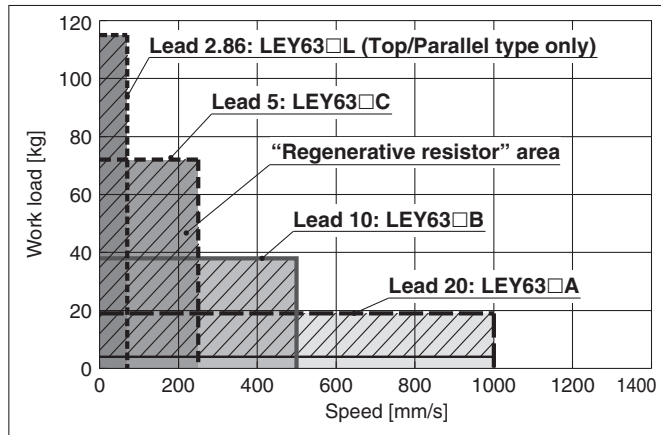

Horizontal

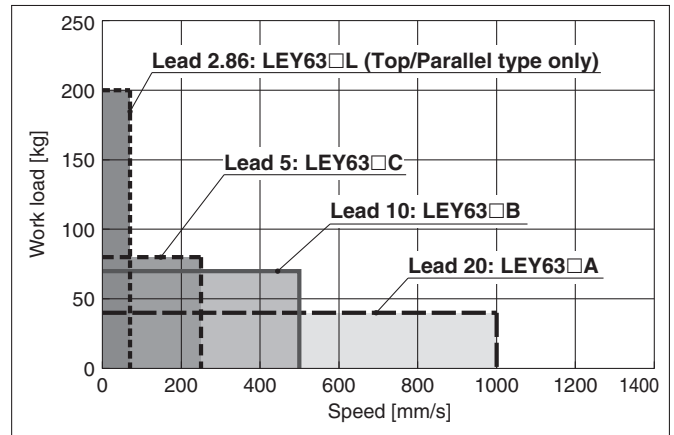

"Regenerative resistor" area

* When using the actuator in the "Regenerative resistor" area, download the "AC servo capacity selection program/SigmaJunmaSize+" from the SMC website. Then, calculate the necessary regenerative resistor capacity to prepare an appropriate external regenerative resistor.

* Regenerative resistor should be provided by the customer.

Applicable Motor/Driver

Product no.	Applicable model	
	Motor	Servopack (SMC driver)
LEY63□	SGMJV-04A3A	SGDV-2R8A11□ (LECYM2-V8) SGDV-2R8A21□ (LECYU2-V8)

Allowable Stroke Speed

[mm/s]

Model	AC servo motor	Lead		Stroke [mm]												
		Symbol	[mm]	Up to 30	Up to 50	Up to 100	Up to 150	Up to 200	Up to 250	Up to 300	Up to 350	Up to 400	Up to 450	Up to 500	Up to 600	Up to 700
LEY25□ (Motor mounting position: Top/Parallel, In-line)	100 W /□40	A	12				900				600	—	—	—	—	—
		B	6				450				300	—	—	—	—	—
		C	3				225				150	—	—	—	—	—
		(Motor rotation speed)					(4500 rpm)				(3000 rpm)	—	—	—	—	—
LEY32□ (Motor mounting position: Top/Parallel)	200 W /□60	A	20				1200					800	—	—	—	—
		B	10				600				400	—	—	—	—	—
		C	5				300				200	—	—	—	—	—
		(Motor rotation speed)					(3600 rpm)				(2400 rpm)	—	—	—	—	—
LEY32D (Motor mounting position: In-line)	200 W /□60	A	16				1000				640	—	—	—	—	—
		B	8				500				320	—	—	—	—	—
		C	4				250				160	—	—	—	—	—
		(Motor rotation speed)					(3750 rpm)				(2400 rpm)	—	—	—	—	—
LEY63□ (Motor mounting position: Top/Parallel, In-line)	400 W /□60	A	20	—					1000				800	600	500	
		B	10	—					500				400	300	250	
		C	5	—					250				200	150	125	
		(Motor rotation speed)		—					(3000 rpm)				(2400 rpm)	(1800 rpm)	(1500 rpm)	
		L	2.86	—							70					
(Motor rotation speed)		—							(1470 rpm)							

Model Selection

LEY

LEYG

LECA6
LECP6

LEC-G

LECP1

LECPA

JXC□1

JXC7□□□□□□□□

LEY

LEYG

LECS□

LECS-T

LECY□

Specific Product Precautions

Series LEY/LEY-X5

Size 25, 32, 63

AC Servo Motor

Force Conversion Graph (Guide)

LEY25□ (Motor mounting position: Top/Parallel, In-line)

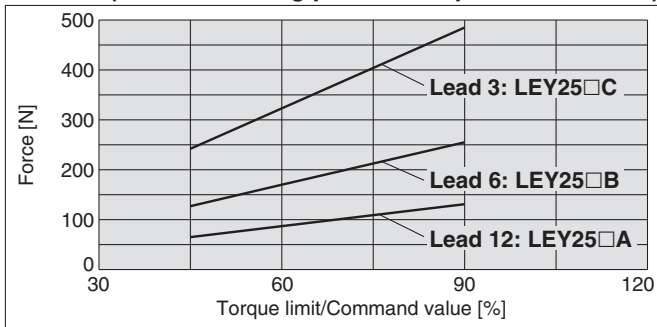

Torque limit/Command value [%]	Duty ratio [%]	Continuous pushing time [minute]
75 or less	100	—
90	60	1.5

LEY32□ (Motor mounting position: Top/Parallel)

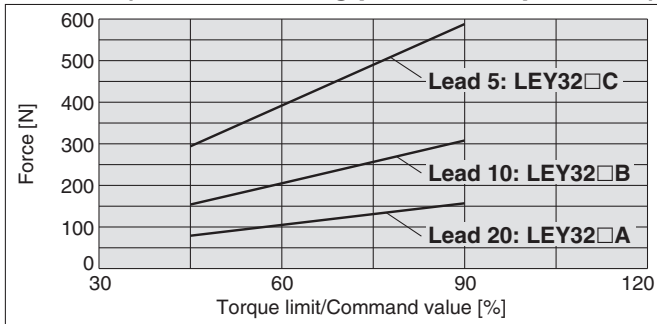

Torque limit/Command value [%]	Duty ratio [%]	Continuous pushing time [minute]
75 or less	100	—
90	60	1.5

LEY32D□ (Motor mounting position: In-line)

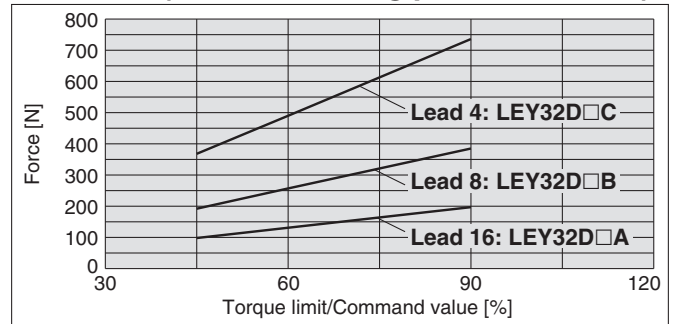

Torque limit/Command value [%]	Duty ratio [%]	Continuous pushing time [minute]
75 or less	100	—
90	60	1.5

LEY63□ (Motor mounting position: Top/Parallel, In-line)

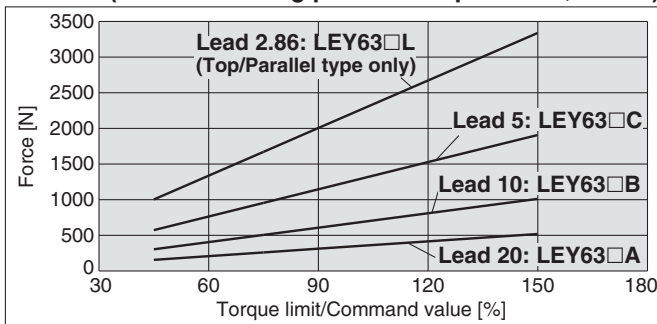

Torque limit/Command value [%]	Duty ratio [%]	Continuous pushing time [minute]
75 or less	100	—
90	60	1.5
120	30	0.5
150	20	0.16

Graph of Allowable Lateral Load on the Rod End (Guide)

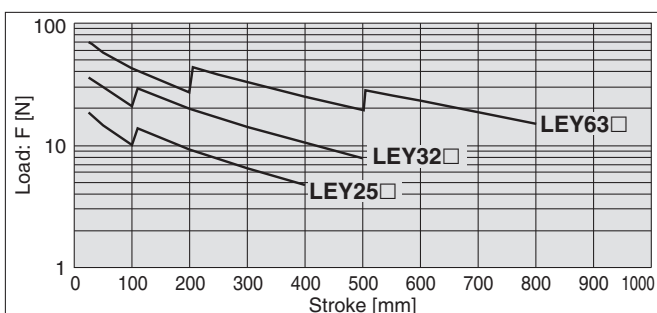

[Stroke] = [Product stroke] + [Distance from the rod end to the centre of gravity of the workpiece]

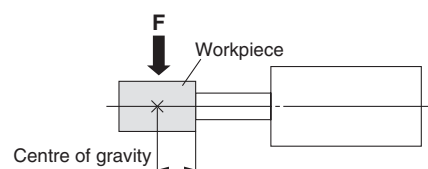

Non-rotating Accuracy: θ

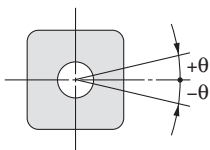

Size	Non-rotating accuracy θ
25	$\pm 0.8^\circ$
32	$\pm 0.7^\circ$
63	$\pm 0.6^\circ$

Rod Displacement: δ

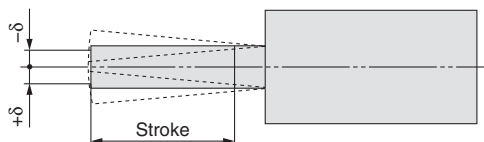

Size	Stroke [mm]													
	30	50	100	150	200	250	300	350	400	450	500	600	700	800
25	± 0.3	± 0.4	± 0.7	± 0.7	± 0.9	± 1.1	± 1.3	± 1.5	± 1.7	—	—	—	—	—
32	± 0.3	± 0.4	± 0.7	± 0.6	± 0.8	± 1.0	± 1.1	± 1.3	± 1.5	± 1.7	± 1.8	—	—	—
63	—	± 0.5	± 0.7	± 0.9	± 1.2	± 1.1	± 1.3	± 1.5	± 1.7	± 1.9	± 2.1	± 1.7	± 2.0	± 2.2

Model Selection

Servo Motor (24 VDC)/Step Motor (Servo/24 VDC)
LEY
LEYG

LECA6
LECP6

LEC-G

LECP1

LECPA

JXC□1

JXC73/83/92/99

AC Servo Motor
LEY
LEYG

LECS□

LECS-T

LECY□

Specific Product Precautions

Electric Actuator/Rod Type

AC Servo Motor

Series LEY-X5

LEY25, 32, 63



RoHS

Please contact SMC for dust-tight/water-jet-proof (IP65 equivalent) and the models compatible with secondary batteries.

How to Order

LEY **H** **25** **V6** **B** - **200** - **S** **3** **M2** - **X5**

1 2 3 4 5 6 7 8 9 10 11 12 13 14

Made to order:
Dust-tight/
Water-jet-proof

1 Accuracy

—	Basic type
H	High precision type

2 Size

25
32
63

3 Motor mounting position

—	Top mounting
R	Right side parallel
L	Left side parallel
D	In-line

4 Motor type

Symbol	Type	Output [W]	Size	Compatible driver
V6	AC servo motor (Absolute encoder)	100	25	LECYM2-V5 LECYU2-V5
V7		200	32	LECYM2-V7 LECYU2-V7
V8		400	63	LECYM2-V8 LECYU2-V8

5 Lead [mm]

Symbol	LEY25	LEY32 *1	LEY63
A	12	16 (20)	20
B	6	8 (10)	10
C	3	4 (5)	5
L	—	—	2.86 *2

- *1 The values shown in () are the lead for top mounting, right/left side parallel types. (Equivalent lead which includes the pulley ratio [1.25:1])
- *2 Only available for top mounting and right/left side parallel types. (Equivalent lead which includes the pulley ratio [4:7])

6 Stroke [mm]

30	30
to	to
800	800

* Refer to the applicable stroke table.

7 Dust-tight/Water-jet-proof (Only available for LEY63)

Symbol	LEY25/32	LEY63
—	IP4x equivalent	IP5x equivalent (Dust-protected)
P	—	IP65 equivalent (Dust-tight/ Water-jet-proof)/With vent hole tap

- * When using the dust-tight/water-jet-proof (IP65 equivalent), correctly mount the fitting and tubing to the vent hole tap, and then place the end of the tubing in an area not exposed to dust or water.
- * The fitting and tubing should be provided separately by the customer. Select [Applicable tubing O.D.: Ø 4 or more, Connection thread: Rc1/8].
- * Cannot be used in environments exposed to cutting oil etc. Take suitable protective measures.

8 Motor option

—	Without option
B	With lock

- * When "With lock" is selected for the top mounting and right/left side parallel types, the motor body will stick out of the end of the body for size 25 with strokes 30 mm or less. Check for interference with workpieces before selecting a model.

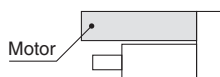

9 Rod end thread

—	Rod end female thread
M	Rod end male thread (1 rod end nut is included.)

Applicable Stroke Table

●: Standard

Model	Stroke [mm]	30	50	100	150	200	250	300	350	400	450	500	600	700	800	Manufacturable stroke range
LEY25		●	●	●	●	●	●	●	●	●	—	—	—	—	—	15 to 400
LEY32		●	●	●	●	●	●	●	●	●	●	●	—	—	—	20 to 500
LEY63		—	—	●	—	●	—	●	—	●	—	●	●	●	●	50 to 800

* Please consult with SMC for the manufacture of intermediate strokes.

For auto switches, refer to pages 232 and 233.

Electric Actuator/Rod Type **Series LEY-X5**

AC Servo Motor

Size **25, 32, 63**

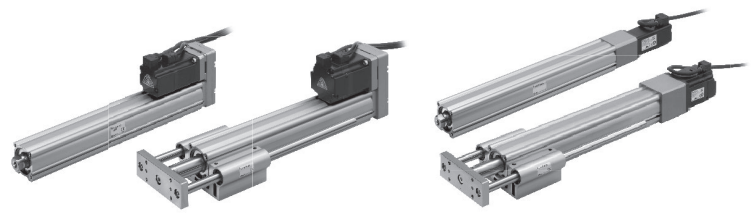

Motor mounting position: Top/Parallel

Motor mounting position: In-line

10 Mounting *1

Symbol	Type	Motor mounting position	
		Top/Parallel	In-line
—	Ends tapped/ Body bottom tapped *2	●	●
L	Foot	●	—
F	Rod flange *2	● *4	●
G	Head flange *2	● *5	—
D	Double clevis *3	●	—

*1 Mounting bracket is shipped together, (but not assembled).

*2 For horizontal cantilever mounting with the ends tapped and rod/head flange, use the actuator within the following stroke range.

· LEY25: 200 mm or less · LEY32: 100 mm or less · LEY63: 400 mm or less

*3 For mounting with the double clevis, use the actuator within the following stroke range.

· LEY25: 200 mm or less · LEY32: 200 mm or less · LEY63: 300 mm or less

*4 Rod flange is not available for the LEY25 with strokes 30 mm and motor option "With lock".

*5 Head flange is not available for the LEY32/LEY63.

11 Cable type

—	Without cable
S	Standard cable
R	Robotic cable (Flexible cable)

12 Cable length [m]

—	Without cable
3	3
5	5
A	10
C	20

13 Driver type

	Compatible driver	Power supply voltage [V]
—	Without driver	—
M2	LECYM2-V□	200 to 230
U2	LECYU2-V□	200 to 230



* When the driver type is selected, the cable is included. Select cable type and cable length.

14 I/O cable length [m] *

—	Without cable
H	Without cable (Connector only)
1	1.5

* When "Without driver" is selected for driver type, only "—: Without cable" can be selected. Refer to Page 246 if I/O cable is required. (Options are shown on Page 246.)

Compatible Drivers

Driver type	MECHATROLINK-II type	MECHATROLINK-III type
		
Series	LECYM	LECYU
Applicable network	MECHATROLINK-II	MECHATROLINK-III
Control encoder	Absolute 20-bit encoder	
Communication device	USB communication, RS-422 communication	
Power supply voltage [V]	200 to 230 VAC (50/60 Hz)	
Reference page	Page 239	

Series LEY-X5

Size 25, 32, 63

AC Servo Motor

Specifications

Model		LEY25 (Top/Parallel)/LEY25D (In-line)			LEY32 (Top/Parallel)			LEY32D (In-line)			
Stroke [mm] ^{Note 1)}		30, 50, 100, 150, 200, 250, 300, 350, 400			30, 50, 100, 150, 200, 250, 300, 350, 400, 450, 500			30, 50, 100, 150, 200, 250, 300, 350, 400, 450, 500			
Work load [kg]	Horizontal ^{Note 2)}	18	50	50	30	60	60	30	60	60	
	Vertical	8	16	30	9	19	37	12	24	46	
Force [N] ^{Note 3)} (Set value: 45 to 90 %)		65 to 131	127 to 255	242 to 485	79 to 157	154 to 308	294 to 588	98 to 197	192 to 385	368 to 736	
Max. ^{Note 4)} speed [mm/s]	Stroke range	Up to 300	900	450	225	1200	600	300	1000	500	250
		305 to 400	600	300	150						
		405 to 500	—	—	—						
Pushing speed [mm/s] ^{Note 5)}		35 or less			30 or less			30 or less			
Max. acceleration/deceleration [mm/s ²]		5000			5000			5000			
Positioning repeatability [mm]	Basic type	±0.02			±0.02			±0.02			
	High precision type	±0.01			±0.01			±0.01			
Lost motion [mm] ^{Note 6)}	Basic type	0.1 or less			0.1 or less			0.1 or less			
	High precision type	0.05 or less			0.05 or less			0.05 or less			
Lead [mm] (including pulley ratio)		12	6	3	20	10	5	16	8	4	
Impact/Vibration resistance [m/s ²] ^{Note 7)}		50/20			50/20			50/20			
Actuation type		Ball screw + Belt (LEY□)/Ball screw (LEY□□)			Ball screw + Belt [1.25:1]			Ball screw			
Guide type		Sliding bushing (Piston rod)			Sliding bushing (Piston rod)			Sliding bushing (Piston rod)			
Operating temperature range [°C]		5 to 40			5 to 40			5 to 40			
Operating humidity range [%RH]		90 or less (No condensation)			90 or less (No condensation)			90 or less (No condensation)			
Conditions for ^{Note 8)} "Regenerative resistor" [kg]	Horizontal	Not required			Not required			Not required			
	Vertical	6 or more			4 or more			4 or more			
Motor output/Size		100 W/□40			200 W/□60			200 W/□60			
Motor type		AC servo motor (200 VAC)			AC servo motor (200 VAC)			AC servo motor (200 VAC)			
Encoder		Absolute 20-bit encoder (Resolution: 1048576 p/rev)									
Power consumption [W] ^{Note 9)}	Horizontal	45			65			65			
	Vertical	145			175			175			
Standby power consumption when operating [W] ^{Note 10)}	Horizontal	2			2			2			
	Vertical	8			8			8			
Max. instantaneous power consumption [W] ^{Note 11)}		445			724			724			
Type ^{Note 12)}		Non-magnetizing lock									
Holding force [N]		131	255	485	157	308	588	197	385	736	
Power consumption [W] at 20 °C ^{Note 13)}		5.5			6			6			
Rated voltage [V]		24 VDC ⁰ / ₁₀ %									

Note 1) Please consult with SMC for non-standard strokes as they are produced as special orders.

Note 2) The maximum value of the horizontal work load. An external guide is necessary to support the load. The actual work load changes according to the condition of the external guide. Please confirm using actual device.

Note 3) The force setting range (set values for the driver) for the pushing operation with the torque control mode, etc. Set it with reference to "Force Conversion Graph (Guide)" on page 207.

Note 4) The allowable speed changes according to the stroke.

Note 5) The allowable collision speed for the pushing operation with the torque control mode, etc.

Note 6) A reference value for correcting an error in reciprocal operation.

Note 7) Impact resistance: No malfunction occurred when the actuator was tested with a drop tester in both an axial direction and a perpendicular direction to the lead screw. (Test was performed with the actuator in the initial state.)

Vibration resistance: No malfunction occurred in a test ranging between 45 to 2000 Hz. Test was performed in both an axial direction and a perpendicular direction to the lead screw. (Test was performed with the actuator in

the initial state.)

Note 8) The work load conditions which require "Regenerative resistor" when operating at the maximum speed (Duty ratio: 100 %). Order the regenerative resistor separately. For details, refer to "Conditions for Regenerative Resistor (Guide)" on pages 205 and 206.

Note 9) The power consumption (including the driver) is for when the actuator is operating.

Note 10) The standby power consumption when operating (including the driver) is for when the actuator is stopped in the set position during the operation.

Note 11) The maximum instantaneous power consumption (including the driver) is for when the actuator is operating.

Note 12) Only when motor option "With lock" is selected.

Note 13) For an actuator with lock, add the power consumption for the lock.

Weight

Product Weight

[kg]

Series	LEY25□ (Motor mounting position: Top/Parallel)										LEY32□ (Motor mounting position: Top/Parallel)									
	Stroke [mm]	30	50	100	150	200	250	300	350	400	30	50	100	150	200	250	300	350	400	450
Weight [kg]	1.2	1.3	1.6	1.7	1.9	2.1	2.2	2.4	2.6	2.3	2.4	2.7	3.2	3.5	3.8	4.0	4.3	4.6	4.9	5.2

Series	LEY25D□ (Motor mounting position: In-line)										LEY32D□ (Motor mounting position: In-line)									
	Stroke [mm]	30	50	100	150	200	250	300	350	400	30	50	100	150	200	250	300	350	400	450
Weight [kg]	1.2	1.3	1.5	1.7	1.9	2.1	2.3	2.4	2.6	2.3	2.4	2.7	3.2	3.5	3.8	4.1	4.3	4.6	4.9	5.2

Additional Weight

[kg]

Size		25	32
Lock		0.30	0.60
Rod end male thread	Male thread	0.03	0.03
	Nut	0.02	0.02
Foot (2 sets including mounting bolt)		0.08	0.14
Rod flange (including mounting bolt)		0.17	0.20
Head flange (including mounting bolt)			
Double clevis (including pin, retaining ring and mounting bolt)		0.16	0.22

Specifications

Model		LEY63□ (Top/Parallel)				LEY63D□ (In-line)			
Stroke [mm] ^{Note 1)}		50, 100, 150, 200, 250, 300, 350, 400, 450, 500, 600, 700, 800							
Work load [kg]	Horizontal ^{Note 2)}	40	70	80	200	40	70	80	
	Vertical	19	38	72	115	19	38	72	
Force [N]/Set value ^{Note 3)} : 45 to 150 % ^{Note 4)}		156 to 521	304 to 1012	573 to 1910	1003 to 3343	156 to 521	304 to 1012	573 to 1910	
Max. speed [mm/s] ^{Note 5)}	Stroke range	Up to 500	1000	500	250	70	1000	500	250
		505 to 600	800	400	200		800	400	200
		605 to 700	600	300	150		600	300	150
		705 to 800	500	250	125		500	250	125
Pushing speed [mm/s] ^{Note 6)}		30 or less							
Max. acceleration/deceleration [mm/s ²]		5000				3000			
Positioning repeatability [mm]	Basic type	±0.02							
	High precision type	±0.01							
Lost motion [mm] ^{Note 7)}	Basic type	0.1 or less							
	High precision type	0.05 or less							
Screw lead [mm] (including pulley ratio)		20	10	5	5 (2.86)	20	10	5	
Impact/Vibration resistance [m/s ²] ^{Note 8)}		50/20							
Actuation type		Ball screw				Ball screw			
Guide type		Sliding bushing (Piston rod)							
Operating temperature range [°C]		5 to 40							
Operating humidity range [%RH]		90 or less (No condensation)							
Conditions for "Regenerative resistor" [kg] ^{Note 9)}	Horizontal	Not required							
	Vertical	2.5 or more							
Motor output/Size		400 W/□60							
Motor type		AC servo motor (200 VAC)							
Encoder		Absolute 20-bit encoder (Resolution: 1048576 p/rev)							
Power consumption [W] ^{Note 10)}	Horizontal	210							
	Vertical	230							
Standby power consumption when operating [W] ^{Note 11)}	Horizontal	2							
	Vertical	18							
Max. instantaneous power consumption [W] ^{Note 12)}		1275							
Type ^{Note 13)}		Non-magnetizing lock							
Holding force [N]		313	607	1146	2006	313	607	1146	
Power consumption [W] at 20 °C ^{Note 14)}		6							
Rated voltage [V]		24 VDC _{-10%}							

- Note 1) Please consult with SMC for non-standard strokes as they are produced as special orders.
- Note 2) The maximum value of the horizontal work load. An external guide is necessary to support the load. The actual work load changes according to the condition of the external guide. Please confirm using actual device.
- Note 3) Set values for the driver.
- Note 4) The force setting range (set values for the driver) for the pushing operation with the torque control mode etc. The pushing force and duty ratio change according to the set value. Set it with reference to "Force Conversion Graph (Guide)" on page 207.
- Note 5) The allowable speed changes according to the stroke.
- Note 6) The allowable collision speed for the pushing operation with the torque control mode etc.
- Note 7) A reference value for correcting an error in reciprocal operation.
- Note 8) Impact resistance: No malfunction occurred when the actuator was tested with a drop tester in both an axial direction and a perpendicular direction to the lead screw. (Test was performed with the actuator in the initial state.)
Vibration resistance: No malfunction occurred in a test ranging between 45 to 2000 Hz. Test was performed in both an axial direction and a perpendicular direction to the lead screw. (Test was performed with the actuator in the initial state.)
- Note 9) The work load conditions which require "Regenerative resistor" when operating at the maximum speed (Duty ratio: 100 %).
- Note 10) The power consumption (including the driver) is for when the actuator is operating.
- Note 11) The standby power consumption when operating (including the driver) is for when the actuator is stopped in the set position during the operation.
- Note 12) The maximum instantaneous power consumption (including the driver) is for when the actuator is operating.
- Note 13) Only when motor option "With lock" is selected.
- Note 14) For an actuator with lock, add the power consumption for the lock.

Weight

Product Weight

Series	LEY63V8 (Motor mounting position: Top/Parallel)												
Stroke [mm]	50	100	150	200	250	300	350	400	450	500	600	700	800
Weight [kg]	4.8	5.3	6.0	6.5	7.7	8.2	8.8	9.3	9.9	10.4	12.1	13.3	14.4

Series	LEY63DV8 (Motor mounting position: In-line)												
Stroke [mm]	50	100	150	200	250	300	350	400	450	500	600	700	800
Weight [kg]	5.0	5.5	6.1	6.6	7.8	8.3	9.0	9.5	10.1	10.6	12.3	13.4	14.6

Additional Weight

Size	63	
Lock	0.6	
Rod end male thread	Male thread	0.12
	Nut	0.04
Foot (2 sets including mounting bolt)	0.26	
Rod flange (including mounting bolt)	0.51	
Double clevis (including pin, retaining ring and mounting bolt)	0.58	

Model Selection

LEY

LEYG

LECA6
LECP6

LEC-G

LECP1

LECPA

JXC□1

JXC7□/□3/□2/□8

AC Servo Motor

LEY

LEYG

LECS□

LECS-T

LECY□

Specific Product Precautions

Series LEY-X5

Size 25, 32, 63

AC Servo Motor

Construction

Motor top mounting type: LEY
25
32
63

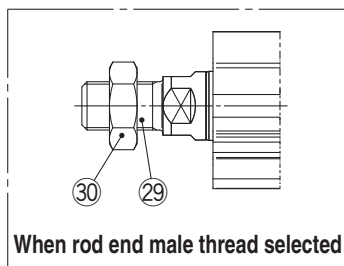
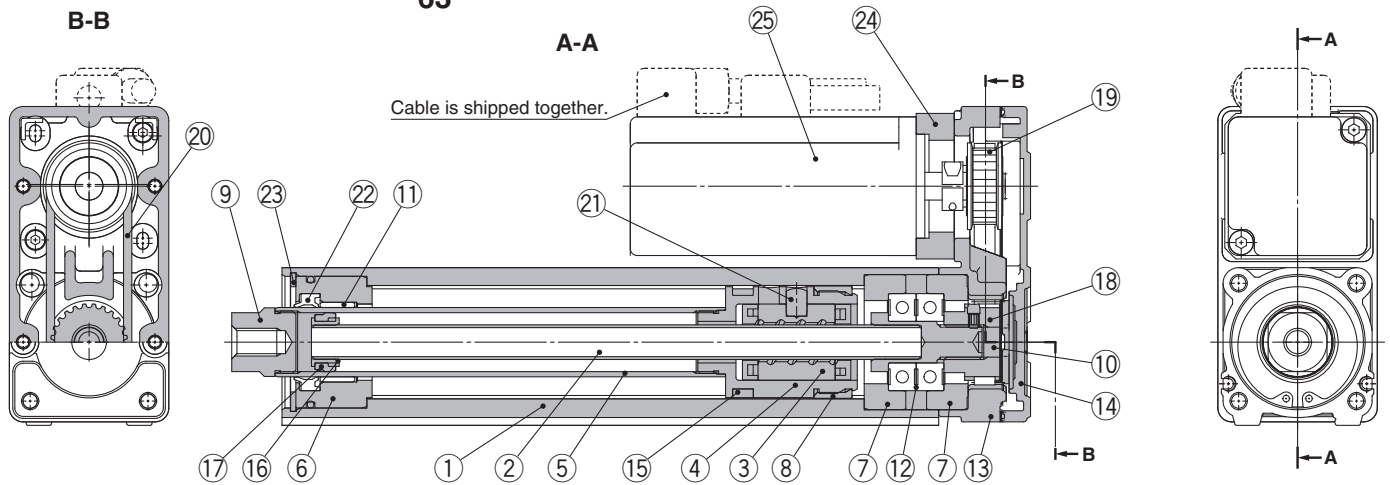

In-line motor type: LEY32D
25
63

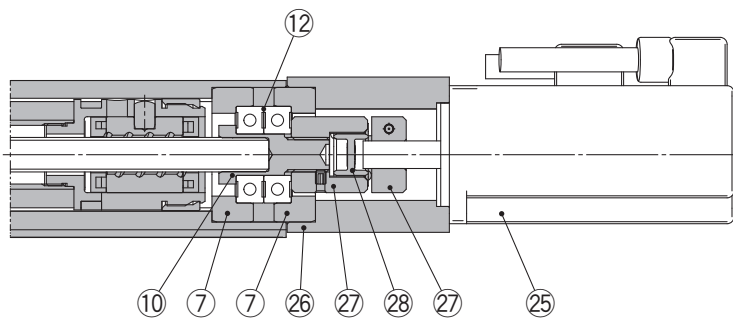

Component Parts

No.	Description	Material	Note
1	Body	Aluminium alloy	Anodised
2	Ball screw shaft	Alloy steel	
3	Ball screw nut	Resin/Alloy steel	
4	Piston	Aluminium alloy	
5	Piston rod	Stainless steel	Hard chrome plated
6	Rod cover	Aluminium alloy	
7	Bearing holder	Aluminium alloy	
8	Rotation stopper	POM	
9	Socket	Free cutting carbon steel	Nickel plated
10	Connected shaft	Free cutting carbon steel	Nickel plated
11	Bushing	Lead bronze cast	
12	Bearing	—	
13	Return box	Aluminium die-cast	Coating
14	Return plate	Aluminium die-cast	Coating
15	Magnet	—	
16	Wear ring holder	Stainless steel	Stroke 101 mm or more
17	Wear ring	POM	Stroke 101 mm or more
18	Screw shaft pulley	Aluminium alloy	

No.	Description	Material	Note
19	Motor pulley	Aluminium alloy	
20	Belt	—	
21	Parallel pin	Stainless steel	
22	Seal	NBR	
23	Retaining ring	Steel for spring	Phosphate coated
24	Motor adapter	Aluminium alloy	Coating
25	Motor	—	
26	Motor block	Aluminium alloy	Coating
27	Hub	Aluminium alloy	
28	Spider	Urethane	
29	Socket (Male thread)	Free cutting carbon steel	Nickel plated
30	Nut	Alloy steel	Zinc chromated

Replacement Parts (Top/Parallel only)/Belt

No.	Size	Order no.	No.	Size	Lead	Order no.
20	25	LE-D-2-2	20	63	A/B/C	LE-D-2-5
	32	LE-D-2-4			L	LE-D-2-6

Dimensions: Motor Top/Parallel

Note 1) Range within which the rod can move. Make sure a workpiece mounted on the rod does not interfere with the workpieces and facilities around the rod.
 Note 2) The direction of rod end width across flats (□K) differs depending on the products.

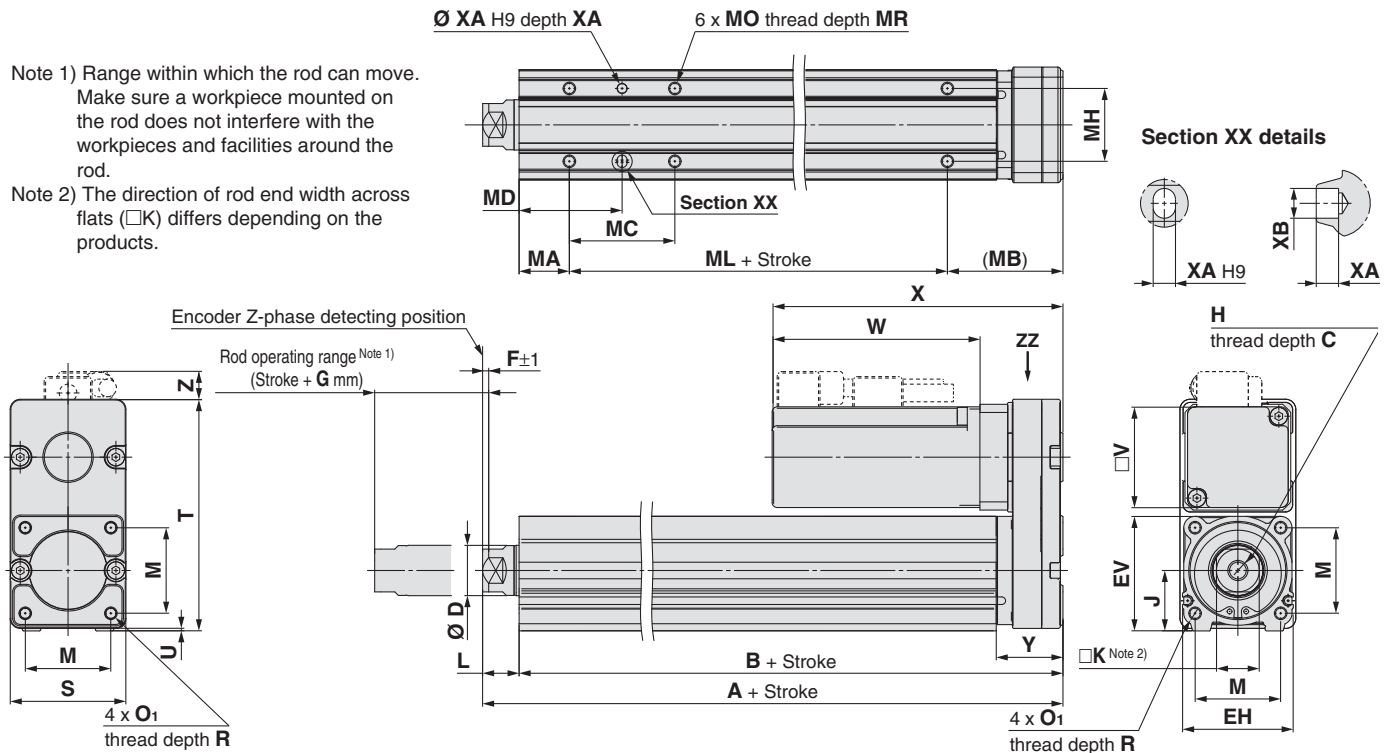

IP65 equivalent (Dust-tight/Water-jet-proof): LEY63□□□□-□P

(View ZZ)

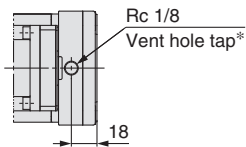

* When using the dust-tight/water-jet-proof (IP65 equivalent), correctly mount the fitting and tubing to the vent hole tap, and then place the end of the tubing in an area not exposed to dust or water. The fitting and tubing should be provided separately by the customer.
 Select [Applicable tubing O.D.: Ø 4 or more, Connection thread: Rc1/8].

Size	Stroke range [mm]	A	B	C	D	EH	EV	H	J	K	L	M	O ₁	R	S	T	U	Y	V
25	15 to 100	130.5	116	13	20	44	45.5	M8 x 1.25	24	17	14.5	34	M5 x 0.8	8	46	92	1	26.5	40
	105 to 400	155.5	141																
32	20 to 100	148.5	130	13	25	51	56.5	M8 x 1.25	31	22	18.5	40	M6 x 1.0	10	60	118	1	34	60
	105 to 500	178.5	160																
63	Up to 200	192.6	155.2	21	40	76	82	M16 x 2	44	36	37.4	60	M8 x 1.25	16	80	146	4	32.2	60
	205 to 500	227.6	190.2																
	505 to 800	262.6	225.2																

Size	Stroke range [mm]	Without lock			With lock			F	G
		W	X	Z	W	X	Z		
25	15 to 100	82.5	115.5	11	127.5	160.5	11	2	4
	105 to 400	82.5	115.5	11	127.5	160.5	11	2	4
32	20 to 100	80	120	14	120	160	14	2	4
	105 to 500	80	120	14	120	160	14	2	4
63	50 to 200	98.5	138.5	12.5 (13.5)*	138.5	178.5	12.5 (13.5)*	4	8
	205 to 500	98.5	138.5	12.5 (13.5)*	138.5	178.5	12.5 (13.5)*	4	8
	505 to 800	98.5	138.5	12.5 (13.5)*	138.5	178.5	12.5 (13.5)*	4	8

* L lead

Size		Body Bottom Tapped [mm]									
Stroke range [mm]	MA	MB	MC	MD	MH	ML	MO	MR	XA	XB	
25	15 to 35	20	46	24	32	29	M5 x 0.8	6.5	4	5	
	40 to 100			42	41						50
	105 to 120			42	41						50
	125 to 200			59	49.5						75
	205 to 400			76	58						75
32	20 to 35	25	55	22	36	30	M6 x 1	8.5	5	6	
	40 to 100			36	43						50
	105 to 120			36	43						50
	125 to 200			53	51.5						80
205 to 500	70	60	80								
63	50 to 70	38	52.2	24	50	44	M8 x 1.25	10	6	7	
	75 to 120			45	60.5						65
	125 to 200			58	67						65
	205 to 500			86	81						100
	505 to 800			86	81						135

Model Selection

LEY

LEYG

LECA6
LECP6

LEC-G

LECP1

LECPA

JXC□1

JXC7303/02/03

LEY

LEYG

LECS□

LECS-T

LECY□

Specific Product Precautions

Series LEY-X5

Size 25, 32, 63

AC Servo Motor

Dimensions: Motor Top/Parallel

Motor left side parallel type: LEY 32 L
25
63

Motor right side parallel type: LEY 32 R
25
63

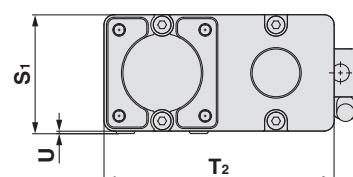
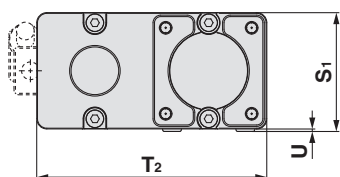
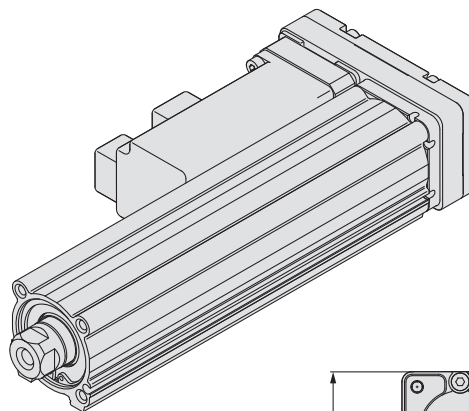
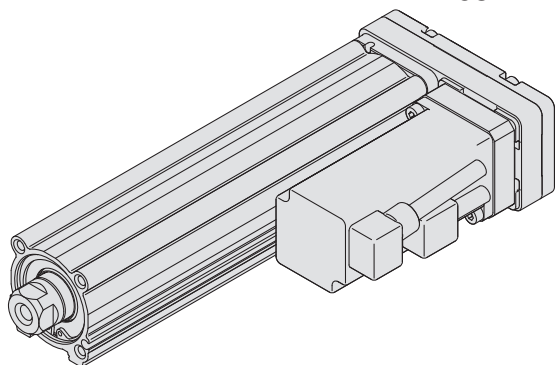

Size	S ₁	T ₂	U
25	47	91	1
32	61	117	1
63	84	142	4

[mm]

Note) When the motor is mounted on the left or right side in parallel, the groove for auto switch on the side to which the motor is mounted is hidden.

Dimensions: In-line Motor

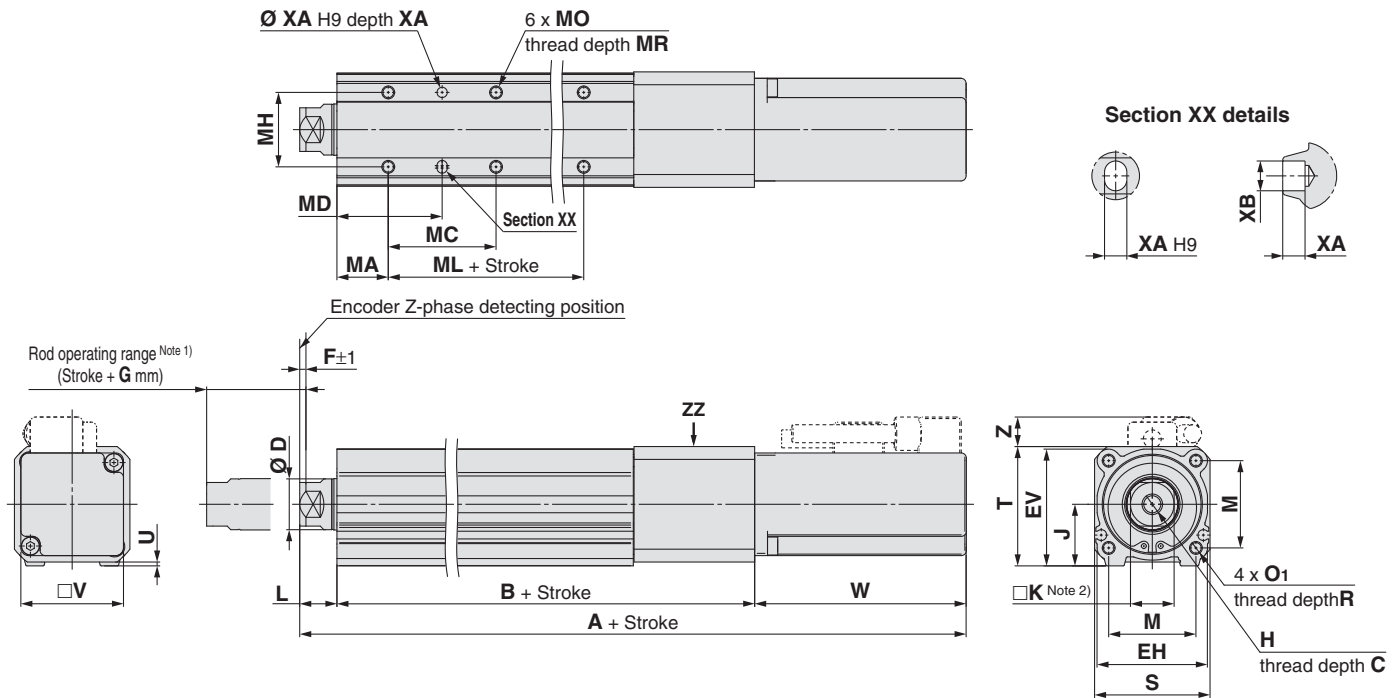

Note 1) Range within which the rod can move.

Make sure a workpiece mounted on the rod does not interfere with the workpieces and facilities around the rod.

Note 2) The direction of rod end width across flats (\square K) differs depending on the products.

Size	Stroke range [mm]	C	D	EH	EV	H	J	K	L	M	O ₁	R	S	T	U	B	V
25	15 to 100	13	20	44	45.5	M8 x 1.25	24	17	14.5	34	M5 x 0.8	8	45	46.5	1.5	136.5	40
	105 to 400															161.5	
32	20 to 100	13	25	51	56.5	M8 x 1.25	31	22	18.5	40	M6 x 1.0	10	60	61	1	156	60
	105 to 500															186	
63	50 to 200	21	40	76	82	M16 x 2	44	36	37.4	60	M8 x 1.25	16	78	83	5	190.7	60
	205 to 500															225.7	
	505 to 800															260.7	

Size	Stroke range [mm]	Without lock			With lock			F	G
		A	W	Z	A	W	Z		
25	15 to 100	233.5	82.5	11.5	278.5	127.5	11.5	2	4
	105 to 400	258.5			303.5				
32	20 to 100	254.5	80	14	294.5	120	14	2	4
	105 to 500	284.5			324.5				
63	50 to 200	326.6	98.5	5	366.6	138.5	5	4	8
	205 to 500	361.6			401.6				
	505 to 800	396.6			436.6				

Body Bottom Tapped

Size	Stroke range [mm]	MA	MC	MD	MH	ML	MO	MR	XA	XB
25	15 to 35	20	24	32	29	50	M5 x 0.8	6.5	4	5
	40 to 100		42	41		75				
	105 to 120		59	49.5						
	125 to 200		76	58						
	205 to 400		76	58						
32	20 to 35	25	22	36	30	50	M6 x 1	8.5	5	6
	40 to 100		36	43		80				
	105 to 120		53	51.5						
	125 to 200		70	60						
	205 to 500		70	60						
63	50 to 70	38	24	50	44	65	M8 x 1.25	10	6	7
	75 to 120		45	60.5		100				
	125 to 200		58	67						
	205 to 500		86	81						
	505 to 800		86	81						

IP65 equivalent (Dust-tight/Water-jet-proof): LEY63D□□-□P

(View ZZ)

*LEY63 only

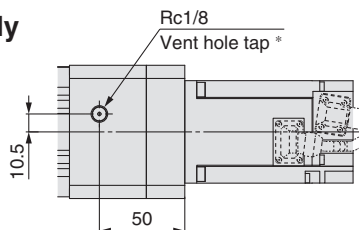

* When using the dust-tight/water-jet-proof (IP65 equivalent), correctly mount the fitting and tubing to the vent hole tap, and then place the end of the tubing in an area not exposed to dust or water. The fitting and tubing should be provided separately by the customer. Select [Applicable tubing O.D.: $\text{Ø} 4$ or more, Connection thread: Rc1/8].

Series LEY-X5

Size 25, 32, 63

AC Servo Motor

Dimensions

End male thread: LEY ²⁵ ³² ⁶³ □□ □□ □□ M

A
B
C
L

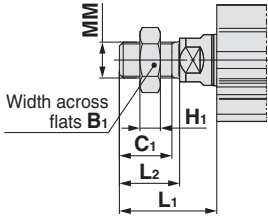

* Refer to page 25 for details about the rod end nut and mounting bracket.
Note) Refer to the "Mounting" precautions on pages 235 and 236 when mounting end brackets such as knuckle joint or workpieces.

Size	B ₁	C ₁	H ₁	L ₁ *	L ₂	MM
25	22	20.5	8	38	23.5	M14 x 1.5
32	22	20.5	8	42.0	23.5	M14 x 1.5
63	27	26	11	76.4	39	M18 x 1.5

* The L₁ measurement is when the unit is in the Z-phase first detecting position. At this position, 2 mm at the end (size 25, 32) and 4 mm at the end (size 63).

Foot: LEY ²⁵ ³² ⁶³ □□ □□ □□ L

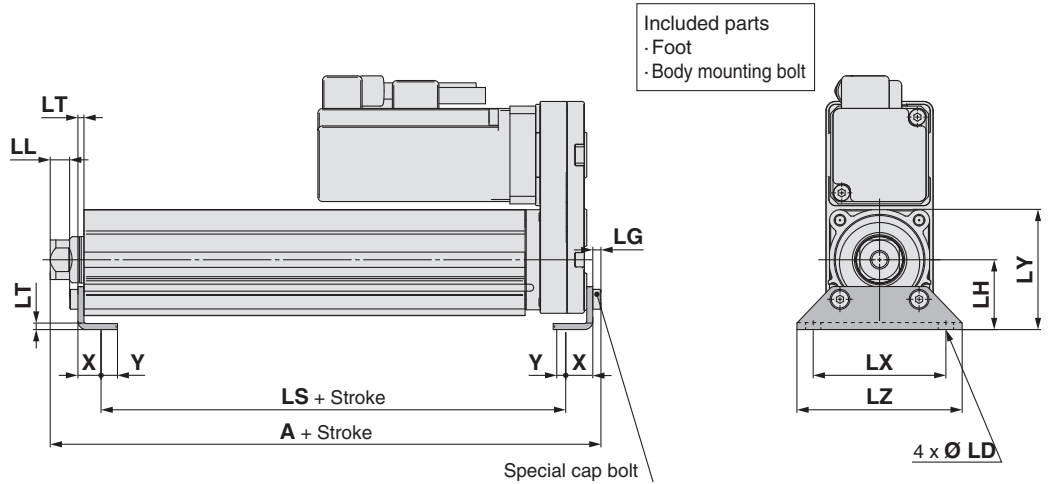
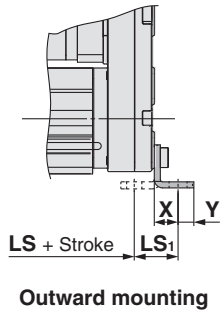

Foot		[mm]												
Size	Stroke range [mm]	A	LS	LS ₁	LL	LD	LG	LH	LT	LX	LY	LZ	X	Y
25	15 to 100	136.6	98.8	19.8	8.4	6.6	3.5	30	2.6	57	51.5	71	11.2	5.8
	105 to 400	161.6	123.8											
32	20 to 100	155.7	114	19.2	11.3	6.6	4	36	3.2	76	61.5	90	11.2	7
	105 to 500	185.7	144											
63	50 to 200	200.8	133.2											
	205 to 500	235.8	168.2	25.2	29.2	8.6	5	50	3.2	95	88	110	14.2	8
	505 to 800	270.8	203.2											

Material: Carbon steel (Chromate treated)

* The A measurement is when the unit is in the Z-phase first detecting position. At this position, 2 mm at the end (size 25, 32) and 4 mm at the end (size 63).

Note) When the motor mounting is the right or left side parallel type, the head side foot should be mounted outwards.

Dimensions

Rod flange: LEY 32 F
 63 F
 A B C L

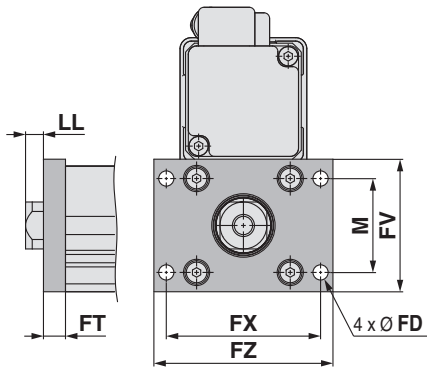

Head flange: LEY 32 G
 63 G
 A B C L

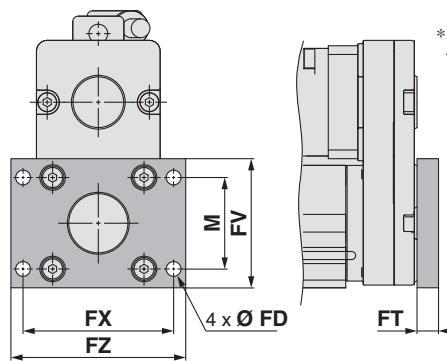

* Head flange is not available for the LEY32/LEY63.

Included parts
 · Flange
 · Body mounting bolt

Rod/Head Flange [mm]

Size	FD	FT	FV	FX	FZ	LL	M
25	5.5	8	48	56	65	6.5	34
32	5.5	8	54	62	72	10.5	40
63	9	9	80	92	108	28.4	60

Material: Carbon steel (Nickel plated)

* The LL measurement is when the unit is in the Z-phase first detecting position. At this position, 2 mm at the end (size 25, 32) and 4 mm at the end (size 63).

Double clevis: LEY 32 D
 63 D
 A B C L

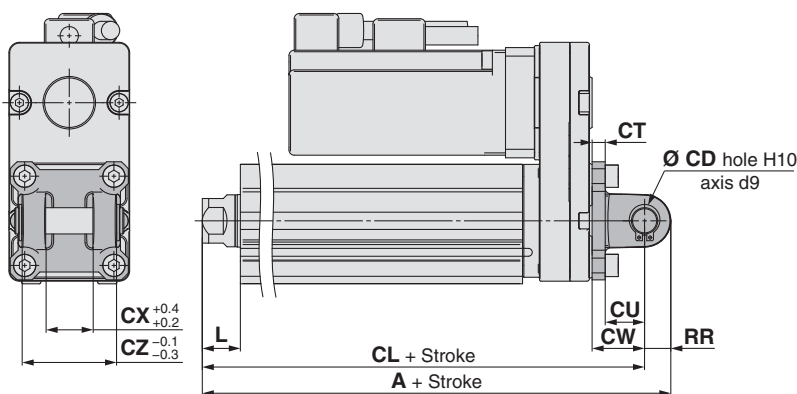

Included parts
 · Double clevis
 · Body mounting bolt
 · Clevis pin
 · Retaining ring

* Refer to Electric Actuators catalogue (CAT.E102) for details about the rod end nut and mounting bracket.

Double Clevis [mm]

Size	Stroke range [mm]	A	CL	CD	CT
25	15 to 100	160.5	150.5	10	5
	105 to 200	185.5	175.5		
32	20 to 100	180.5	170.5	10	6
	105 to 200	210.5	200.5		
63	50 to 200	236.6	222.6	14	8
	205 to 500	271.6	257.6		
	505 to 800	306.6	292.6		

Size	Stroke range [mm]	CU	CW	CX	CZ	L	RR
25	15 to 100	14	20	18	36	14.5	10
	105 to 200						
32	20 to 100	14	22	18	36	18.5	10
	105 to 200						
63	50 to 200	22	30	22	44	37.4	14
	205 to 500						
	505 to 800						

Material: Cast iron (Coating)

* The A and CL measurements are when the unit is in the Z-phase first detecting position. At this position, 2 mm at the end (size 25, 32) and 4 mm at the end (size 63).

Model Selection

LEY

LEYG

LEYG

LECA6
LECP6

LEC-G

LECP1

LECPA

JXC11

JXC303/32/33

LEY

LEYG

LECS

LECS-T

LECY

Specific Product Precautions

Model Selection

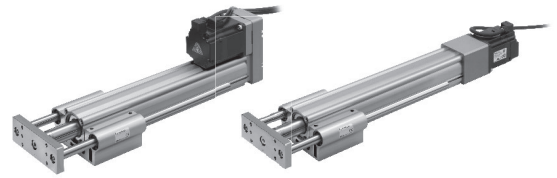

Moment Load Graph

Selection conditions

Mounting position	Vertical		Horizontal	
Max. speed [mm/s]	"Speed-Work Load Graph"		200 or less	Over 200
Graph (Sliding bearing type)	①, ②		⑤, ⑥*	⑦, ⑧
Graph (Ball bushing bearing type)	③, ④		⑨, ⑩	⑪, ⑫

* For the sliding bearing type, the speed is restricted with a horizontal/moment load.

Vertical Mounting, Sliding Bearing

① 70 stroke or less

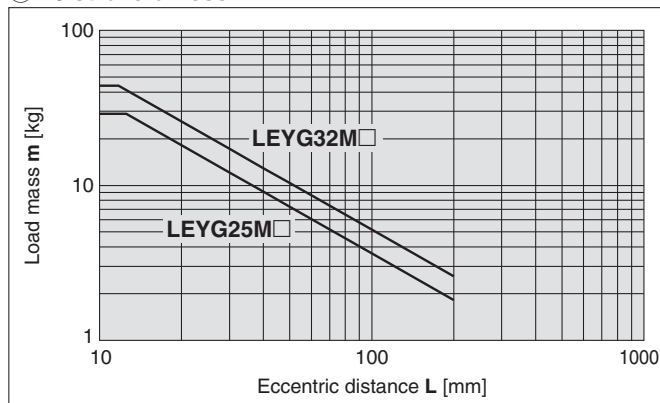

* The limit of vertical load mass varies depending on "lead" and "speed".
Check "Speed-Work Load Graph" on page 221.

② Over 75 stroke

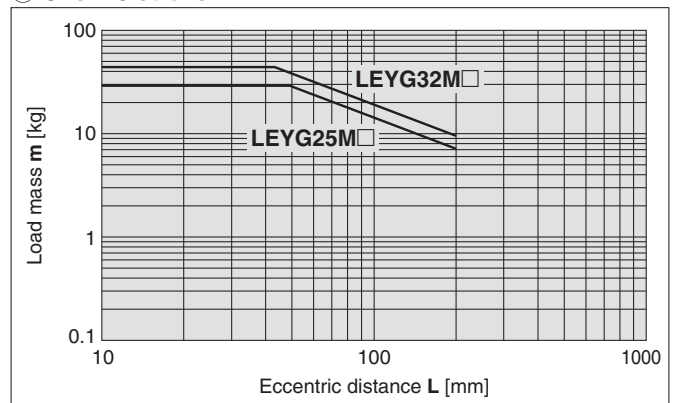

Vertical Mounting, Ball Bushing Bearing

③ 35 stroke or less

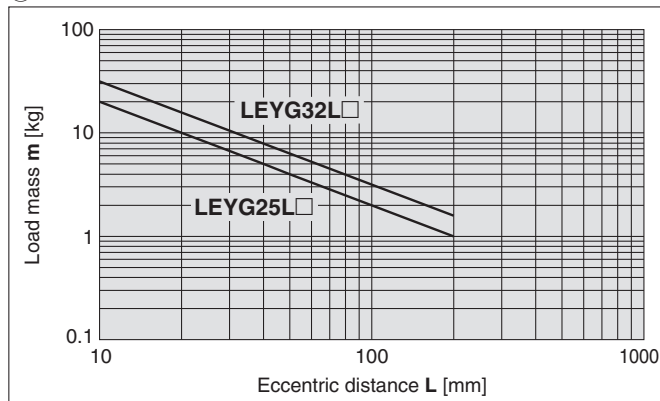

* The limit of vertical load mass varies depending on "lead" and "speed".
Check "Speed-Work Load Graph" on page 221.

④ Over 40 stroke

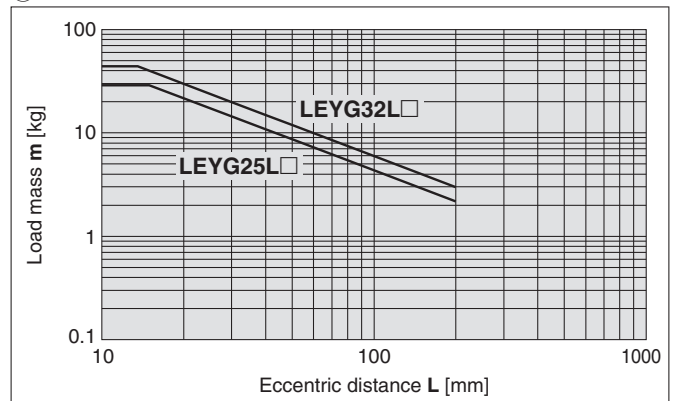

Moment Load Graph

Horizontal Mounting, Sliding Bearing

⑤ L = 50 mm Max. speed = 200 mm/s or less

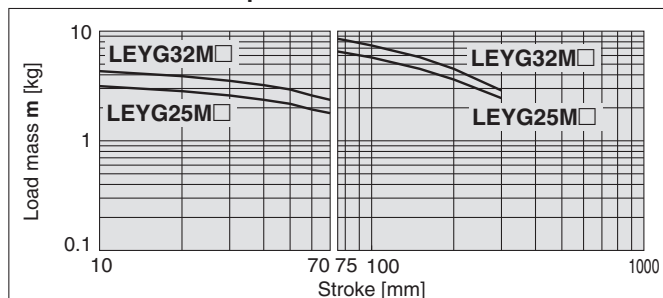

⑥ L = 100 mm Max. speed = 200 mm/s or less

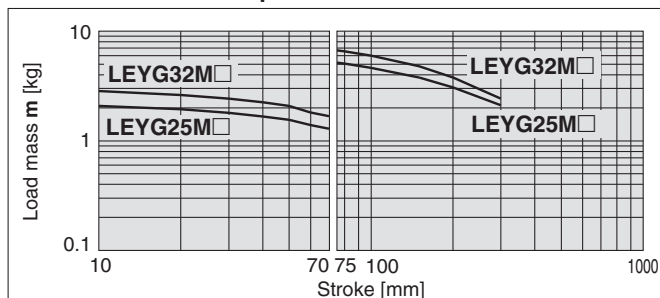

⑦ L = 50 mm Max. speed = Over 200 mm/s

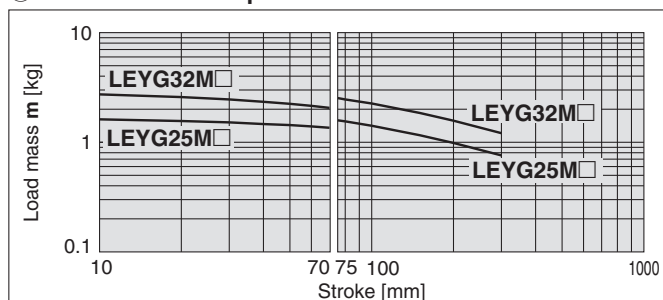

⑧ L = 100 mm Max. speed = Over 200 mm/s

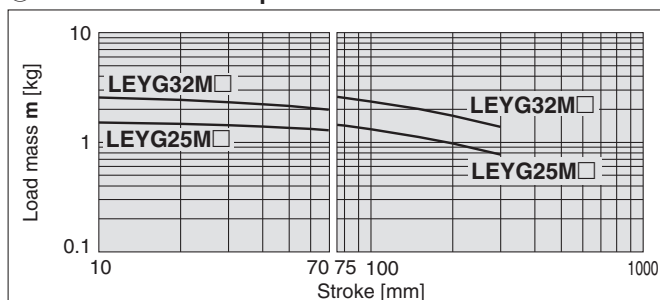

Horizontal Mounting, Ball Bushing Bearing

⑨ L = 50 mm Max. speed = 200 mm/s or less

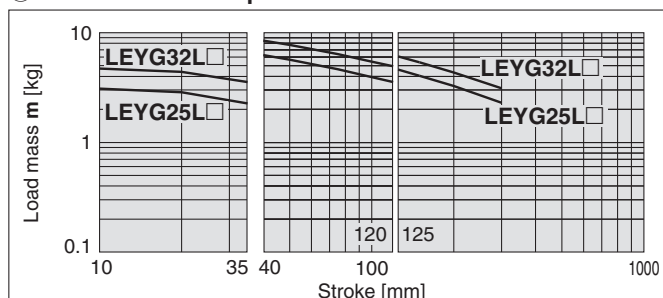

⑩ L = 100 mm Max. speed = 200 mm/s or less

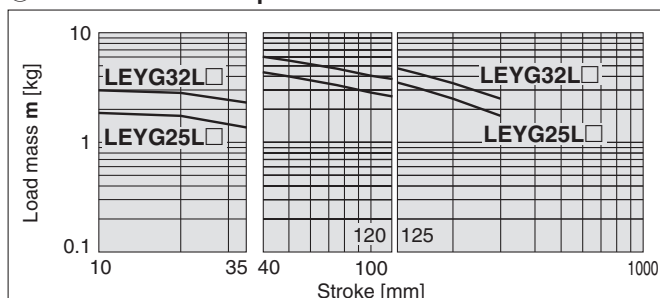

⑪ L = 50 mm Max. speed = Over 200 mm/s

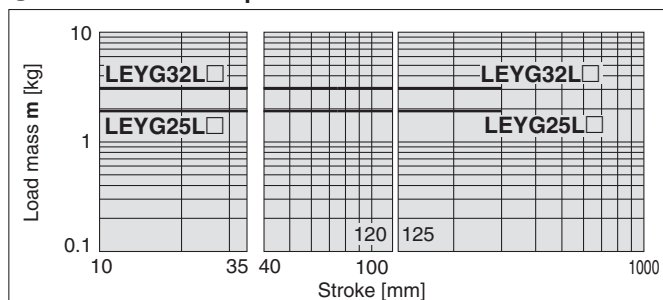

⑫ L = 100 mm Max. speed = Over 200 mm/s

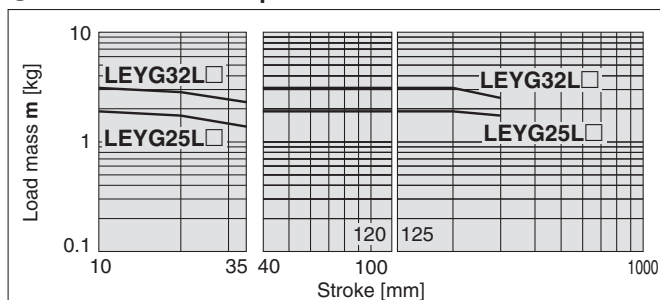

Operating Range when Used as Stopper

LEYG□M (Sliding bearing)

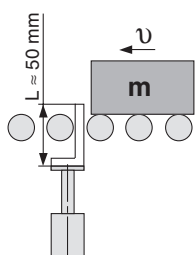

⚠ Caution

Handling Precautions

- Note 1) When used as a stopper, select a model with 30 stroke or less.
- Note 2) LEYG□L (ball bushing bearing) cannot be used as a stopper.
- Note 3) Workpiece collision in series with guide rod cannot be permitted (Fig. a).
- Note 4) The body should not be mounted on the end. It must be mounted on the top or bottom (Fig. b).

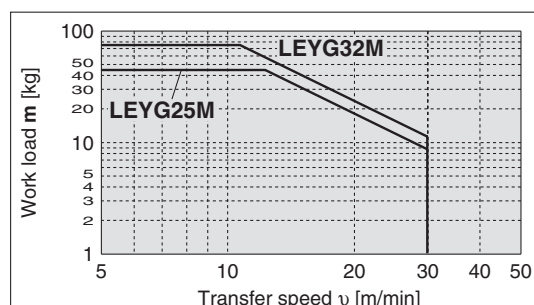
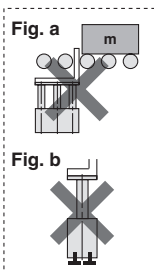

Series LEYG

AC Servo Motor

Speed-Work Load Graph/Conditions for “Regenerative Resistor” (Guide)

LEYG25□V6 (Motor mounting position: Top mounting/In-line)

Vertical

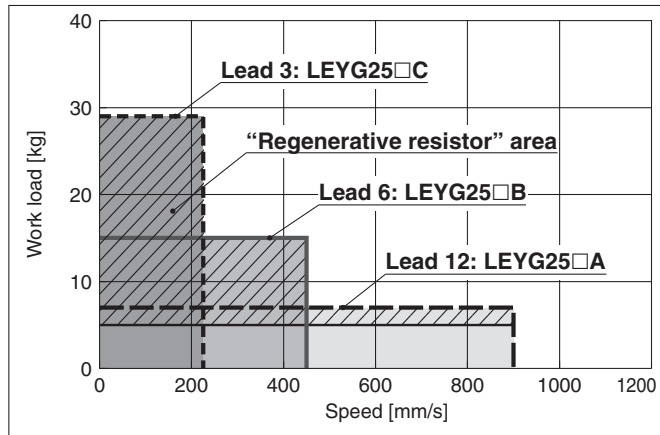

Horizontal

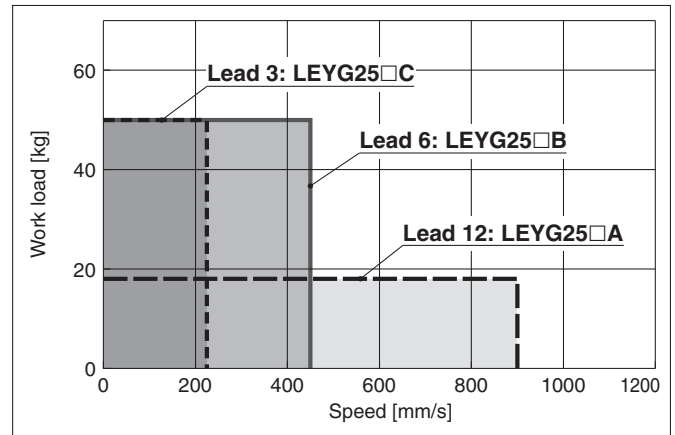

LEYG32□V7 (Motor mounting position: Top mounting)

Vertical

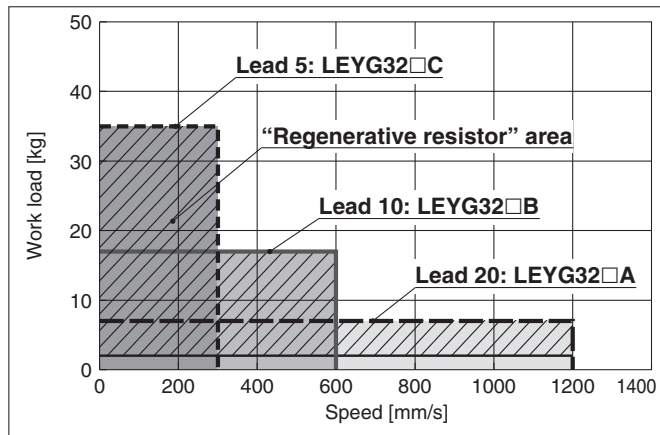

Horizontal

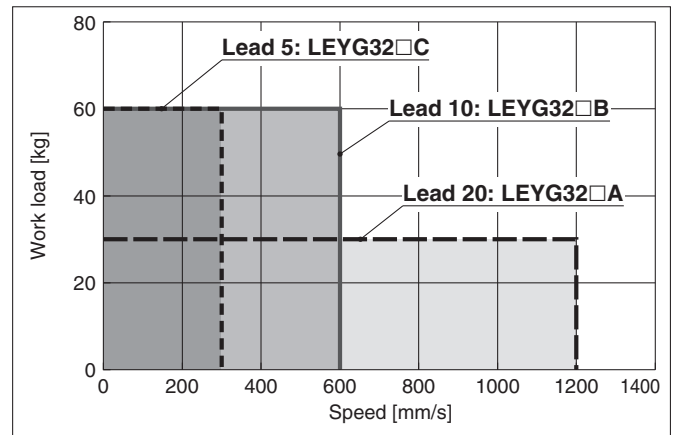

LEYG32□DV7 (Motor mounting position: In-line)

Vertical

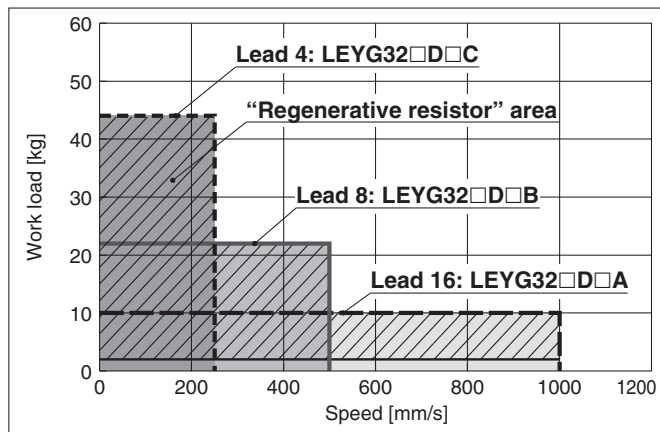

Horizontal

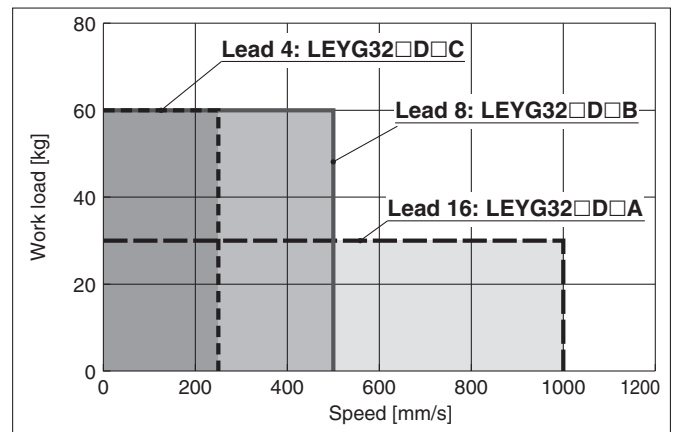

“Regenerative resistor” area

* When using the actuator in the “Regenerative resistor” area, download the “AC servo capacity selection program/SigmaJunmaSize+” from the SMC website. Then, calculate the necessary regenerative resistor capacity to prepare an appropriate external regenerative resistor.

* Regenerative resistor should be provided by the customer.

Applicable Motor/Driver

Model	Applicable model	
	Motor	Servopack (SMC driver)
LEYG25□	SGMJV-01A3A	SGDV-R90A11□ (LECYM2-V5) SGDV-R90A21□ (LECYU2-V5)
LEYG32□	SGMJV-02A3A	SGDV-1R6A11□ (LECYM2-V7) SGDV-1R6A21□ (LECYU2-V7)

Force Conversion Graph

LEYG25□ (Motor mounting position: Top mounting/In-line)

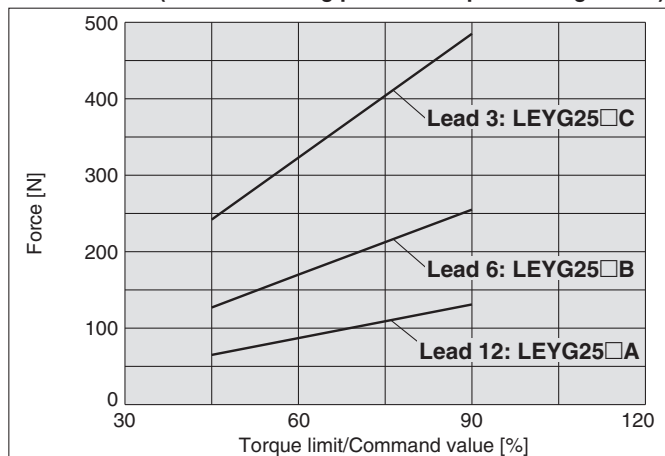

Torque limit/Command value [%]	Duty ratio [%]	Continuous pushing time [minute]
75 or less	100	—
90	60	1.5

LEYG32□ (Motor mounting position: Top mounting)

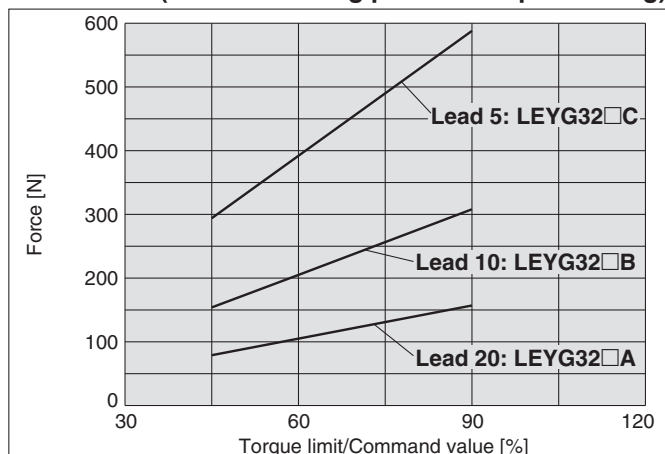

Torque limit/Command value [%]	Duty ratio [%]	Continuous pushing time [minute]
75 or less	100	—
90	60	1.5

LEYG32D (Motor mounting position: In-line)

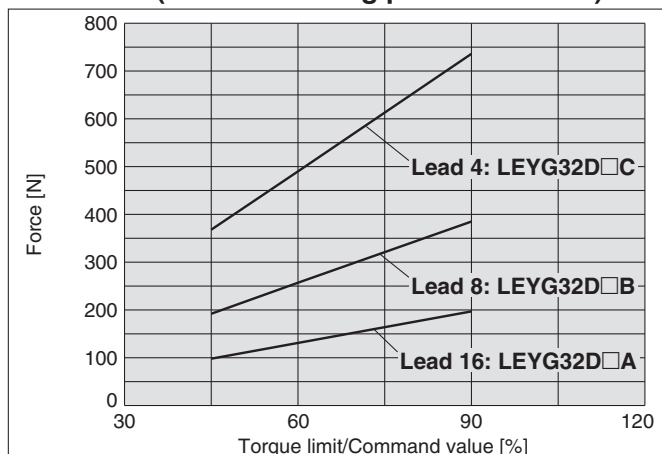

Torque limit/Command value [%]	Duty ratio [%]	Continuous pushing time [minute]
75 or less	100	—
90	60	1.5

Model Selection

LEY

LEYG

LECA6
LECP6

LEC-G

LECP1

LECPA

JXC□1

JXC7303/02/03

LEY

LEYG

LECS□

LECS-T

LECY□

Specific Product Precautions

Series LEYG

AC Servo Motor

Allowable Rotational Torque of Plate: T

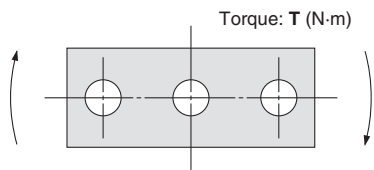

Model	Stroke [mm]					T [N-m]
	30	50	100	200	300	
LEYG25M	1.56	1.29	3.50	2.18	1.36	
LEYG25L	1.52	3.57	2.47	2.05	1.44	
LEYG32M	2.55	2.09	5.39	3.26	1.88	
LEYG32L	2.80	5.76	4.05	3.23	2.32	

Non-rotating Accuracy of Plate: θ

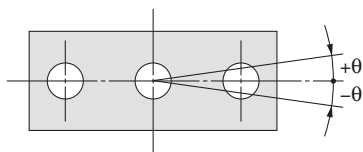

Size	LEYG□M	LEYG□L
25	±0.05°	±0.04°
32		

Plate Displacement: δ

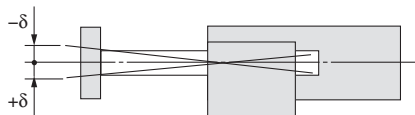

Model	Stroke [mm]					[mm]
	30	50	100	200	300	
LEYG25M	±0.26	±0.31	±0.25	±0.38	±0.36	
LEYG25L	±0.13	±0.13	±0.17	±0.20	±0.23	
LEYG32M	±0.23	±0.29	±0.23	±0.36	±0.34	
LEYG32L	±0.11	±0.11	±0.15	±0.19	±0.22	

Specific Product Precautions	LECY	LECSS-T	LECS	AC Servo Motor		JXC73/63/52/33	JXC	LECPA	LECP1	LEC-G	LECA6 LECP6	Servo Motor (24 VDC)/Step Motor (Servo/24 VDC)		Model Selection
				LEYG	LEY							LEYG	LEY	

Electric Actuator/Guide Rod Type

AC Servo Motor

Series LEYG

LEYG25, 32



How to Order

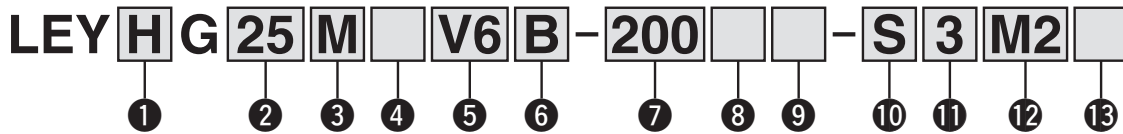

1 Accuracy

—	Basic type
H	High precision type

2 Size

25
32

3 Bearing type

M	Sliding bearing
L	Ball bushing bearing

4 Motor mounting position

—	Top mounting
D	In-line

5 Motor type

Symbol	Type	Output [W]	Actuator size	Compatible driver
V6	AC servo motor (Absolute encoder)	100	25	LECYM2-V5 LECYU2-V5
V7		200	32	LECYM2-V7 LECYU2-V7

6 Lead [mm]

Symbol	LEYG25	LEYG32 *
A	12	16 (20)
B	6	8 (10)
C	3	4 (5)

* The values shown in () are the lead for top mounting type. (Equivalent lead which includes the pulley ratio [1.25:1])

7 Stroke [mm]

30	30
to	to
300	300

* Refer to the applicable stroke table.
* There is a limit for mounting size 3 2 top mounting type and 50 mm stroke or less. Refer to the dimensions.

8 Motor option

—	Without option
B	With lock

* When "With lock" is selected for the top mounting type, the motor body will stick out of the end of the body for size 25 with strokes 30 mm or less. Check for interference with workpieces before selecting a model.

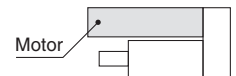

9 Guide option

—	Without option
F	With grease retaining function

* Only available for the sliding bearing.

10 Cable type

—	Without cable
S	Standard cable
R	Robotic cable (Flexible cable)

11 Cable length [m]

—	Without cable
3	3
5	5
A	10
C	20

Applicable Stroke Table

Model	Stroke [mm]	30	50	100	150	200	250	300	Manufacturable stroke range
		●	●	●	●	●	●	●	
LEYG25		●	●	●	●	●	●	●	15 to 300
LEYG32		●	●	●	●	●	●	●	20 to 300

* Please consult with SMC for the manufacture of intermediate strokes.

For auto switches, refer to pages 232 and 233.

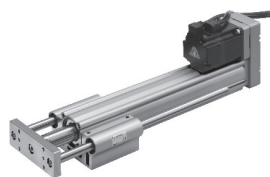

Motor mounting position: Top mounting



Motor mounting position: In-line

12 Driver type

	Compatible driver	Power supply voltage [V]
—	Without driver	—
M2	LECYM2-V□	200 to 230
U2	LECYU2-V□	200 to 230

* When the driver type is selected, the cable is included.
Select cable type and cable length.

13 I/O cable length [m] *



—	Without cable
H	Without cable (Connector only)
1	1.5

* When "Without driver" is selected for driver type, only "—: Without cable" can be selected.
Refer to Page 246 if I/O cable is required.
(Options are shown on Page 246.)

Use of auto switches for the guide rod type LEYG series

- Insert the auto switch from the front side with rod (plate) sticking out.
- For the parts hidden behind the guide attachment (Rod stick out side), the auto switch cannot be fixed.
- Consult with SMC when using auto switch on the rod stick out side.

Compatible Drivers

Driver type	MECHATROLINK-II type	MECHATROLINK-III type
		
Series	LECYM	LECYU
Applicable network	MECHATROLINK-II	MECHATROLINK-III
Control encoder	Absolute 20-bit encoder	
Communication device	USB communication, RS-422 communication	
Power supply voltage [V]	200 to 230 VAC (50/60 Hz)	
Reference page	Page 239	

Series LEYG

AC Servo Motor

Specifications

Model		LEYG25 ^M (Top mounting) LEYG25 ^{LD} (In-line)			LEYG32 ^M (Top mounting)			LEYG32 ^{LD} (In-line)			
Actuator specifications	Stroke [mm] ^{Note 1)}	30, 50, 100, 150, 200, 250, 300			30, 50, 100, 150, 200, 250, 300			30, 50, 100, 150, 200, 250, 300			
	Work load [kg]	Horizontal ^{Note 2)}	18	50	50	30	60	60	30	60	60
		Vertical	7	15	29	7	17	35	10	22	44
	Force [N] ^{Note 3)} (Set value: 45 to 90 %)	65 to 131	127 to 255	242 to 485	79 to 157	154 to 308	294 to 588	98 to 197	192 to 385	368 to 736	
	Max. speed [mm/s]	900	450	225	1200	600	300	1000	500	250	
	Pushing speed [mm/s] ^{Note 4)}	35 or less			30 or less			30 or less			
	Max. acceleration/deceleration [mm/s ²]	5000			5000			5000			
	Positioning repeatability [mm]	Basic type	±0.02			±0.02			±0.02		
		High precision type	±0.01			±0.01			±0.01		
	Lost motion [mm]	Basic type	0.1 or less			0.1 or less			0.1 or less		
		High precision type	0.05 or less			0.05 or less			0.05 or less		
	Lead [mm] (including pulley ratio)	12	6	3	20	10	5	16	8	4	
	Impact/Vibration resistance [m/s ²] ^{Note 5)}	50/20			50/20			50/20			
	Actuation type	Ball screw + Belt [1:1]/Ball screw			Ball screw + Belt [1:1.25]			Ball screw			
	Guide type	Sliding bearing (LEYG□M), Ball bushing bearing (LEYG□L)									
Operating temperature range [°C]	5 to 40			5 to 40			5 to 40				
Operating humidity range [%RH]	90 or less (No condensation)			90 or less (No condensation)			90 or less (No condensation)				
Conditions for ^{Note 6)} "Regenerative resistor" [kg]	Horizontal	Not required			Not required			Not required			
	Vertical	5 or more			2 or more			2 or more			
Motor output/Size	100 W/□40			200 W/□60			200 W/□60				
Motor type	AC servo motor (200 VAC)			AC servo motor (200 VAC)			AC servo motor (200 VAC)				
Encoder	Absolute 20-bit encoder (Resolution: 1048576 p/rev)										
Power consumption [W] ^{Note 7)}	Horizontal	45			65			65			
	Vertical	145			175			175			
Standby power consumption when operating [W] ^{Note 8)}	Horizontal	2			2			2			
Max. instantaneous power consumption [W] ^{Note 9)}	Horizontal	8			8			8			
	Vertical	445			724			724			
Type ^{Note 10)}	Non-magnetizing lock			Non-magnetizing lock			Non-magnetizing lock				
Holding force [N]	131	255	485	157	308	588	197	385	736		
Power consumption at 20 °C [W] ^{Note 11)}	5.5			6			6				
Rated voltage [V]	24 VDC ⁰ / ₋₁₀ %										

Note 1) Please consult with SMC for non-standard strokes as they are produced as special orders.
 Note 2) The maximum value of the horizontal work load. An external guide is necessary to support the load. The actual work load changes according to the condition of the external guide. Please confirm using actual device.
 Note 3) The force setting range (set values for the driver) for the pushing operation with the torque control mode, etc. Set it with reference to "Force Conversion Graph" on page 222.
 Note 4) The allowable collision speed for the pushing operation with the torque control mode, etc.
 Note 5) Impact resistance: No malfunction occurred when the actuator was tested with a drop tester in both an axial direction and a perpendicular direction to the lead screw. (Test was performed with the actuator in the initial state.)
 Vibration resistance: No malfunction occurred in a test ranging between 45 to 2000 Hz. Test was performed in both an axial direction and a perpendicular direction to the lead screw. (Test was performed with the actuator in the initial state.)

Note 6) The work load conditions which require "Regenerative resistor" when operating at the maximum speed (Duty ratio: 100 %). Order the regenerative resistor separately. For details, refer to "Conditions for Regenerative Resistor (Guide)" on page 221.
 Note 7) The power consumption (including the driver) is for when the actuator is operating.
 Note 8) The standby power consumption when operating (including the driver) is for when the actuator is stopped in the set position during operation.
 Note 9) The maximum instantaneous power consumption (including the driver) is for when the actuator is operating.
 Note 10) Only when motor option "With lock" is selected.
 Note 11) For an actuator with lock, add the power consumption for the lock.

Weight

Product Weight: Top Mounting Type

Series	LEYG25M							LEYG32M						
	Stroke [mm]	30	50	100	150	200	250	300	30	50	100	150	200	250
Weight [kg]	1.7	1.9	2.2	2.6	3.0	3.3	3.6	3.1	3.4	4.0	4.7	5.3	5.7	6.2

Series	LEYG25L							LEYG32L						
	Stroke [mm]	30	50	100	150	200	250	300	30	50	100	150	200	250
Weight [kg]	1.7	1.9	2.2	2.6	2.9	3.2	3.4	3.1	3.4	3.8	4.5	5.0	5.5	5.9

Product Weight: In-line Motor Type

Series	LEYG25MD							LEYG32MD						
	Stroke [mm]	30	50	100	150	200	250	300	30	50	100	150	200	250
Weight [kg]	1.7	1.9	2.2	2.6	3.0	3.3	3.6	3.2	3.4	4.0	4.7	5.3	5.8	6.2

Series	LEYG25LD							LEYG32LD						
	Stroke [mm]	30	50	100	150	200	250	300	30	50	100	150	200	250
Weight [kg]	1.7	2.0	2.2	2.6	2.9	3.2	3.4	3.2	3.4	3.8	4.6	5.0	5.5	5.9

Additional Weight [kg]

Size	25	32
Lock	0.3	0.6

Construction

Motor mounting position: Top mounting type

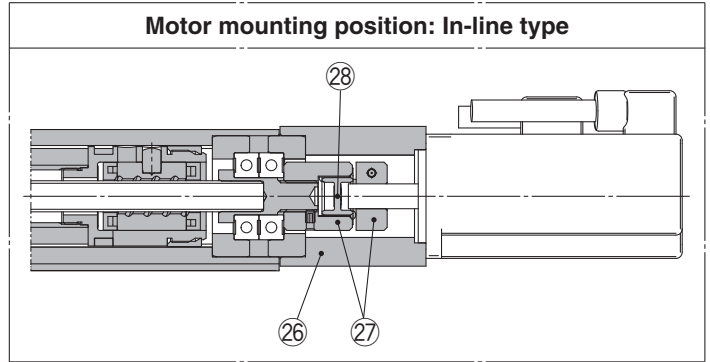
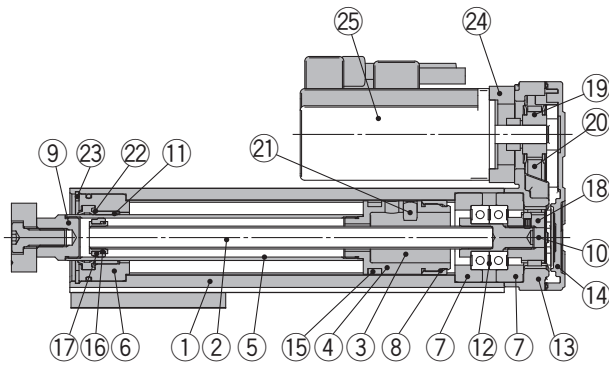

LEYG□M

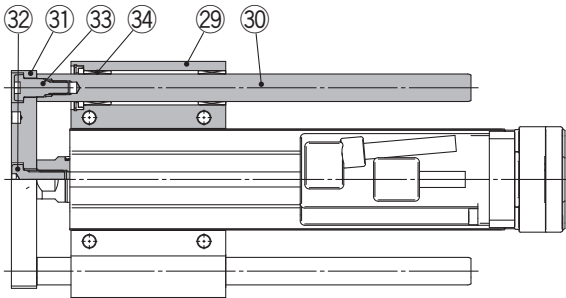

LEYG□L

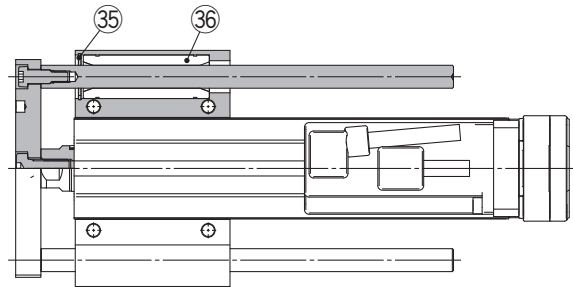

Component Parts

No.	Description	Material	Note
1	Body	Aluminium alloy	Anodised
2	Ball screw shaft	Alloy steel	
3	Ball screw nut	—	
4	Piston	Aluminium alloy	
5	Piston rod	Stainless steel	Hard chrome plated
6	Rod cover	Aluminium alloy	
7	Bearing holder	Aluminium alloy	
8	Rotation stopper	POM	
9	Socket	Free cutting carbon steel	Nickel plated
10	Connected shaft	Free cutting carbon steel	Nickel plated
11	Bushing	Lead bronze cast	
12	Bearing	—	
13	Return box	Aluminium die-cast	Trivalent chromated
14	Return plate	Aluminium die-cast	Trivalent chromated
15	Magnet	—	
16	Wear ring holder	Stainless steel	Stroke 101 mm or more
17	Wear ring	POM	Stroke 101 mm or more
18	Screw shaft pulley	Aluminium alloy	

Support Block

Size	Order no.
25	LEYG-S025
32	LEYG-S032

* Two body mounting bolts are included with the support block.

No.	Description	Material	Note
19	Motor pulley	Aluminium alloy	
20	Belt	—	
21	Parallel pin	Stainless steel	
22	Seal	NBR	
23	Retaining ring	Steel for spring	Phosphate coated
24	Motor adapter	Aluminium alloy	Anodised
25	Motor	—	
26	Motor block	Aluminium alloy	Anodised
27	Hub	Aluminium alloy	
28	Spider	Urethane	
29	Guide attachment	Aluminium alloy	Anodised
30	Guide rod	Carbon steel	
31	Plate	Aluminium alloy	Anodised
32	Plate mounting bolt	Carbon steel	Nickel plated
33	Guide bolt	Carbon steel	Nickel plated
34	Sliding bearing	—	
35	Retaining ring	Steel for spring	Phosphate coated
36	Ball bushing	—	

Replacement Parts/Belt

Size	Order no.
25	LE-D-2-2
32	LE-D-2-4

Model Selection

LEY

LEYG

LECA6
LECP6

LEC-G

LECP1

LECPA

JXC□1

JXC7□/□3/□2/□3

LEY

LEYG

LECS□

LECS-T

LECY□

Specific Product Precautions

Servo Motor (24 VDC)/Step Motor (Servo/24 VDC)

AC Servo Motor

Series LEYG

AC Servo Motor

Dimensions: Top Mounting

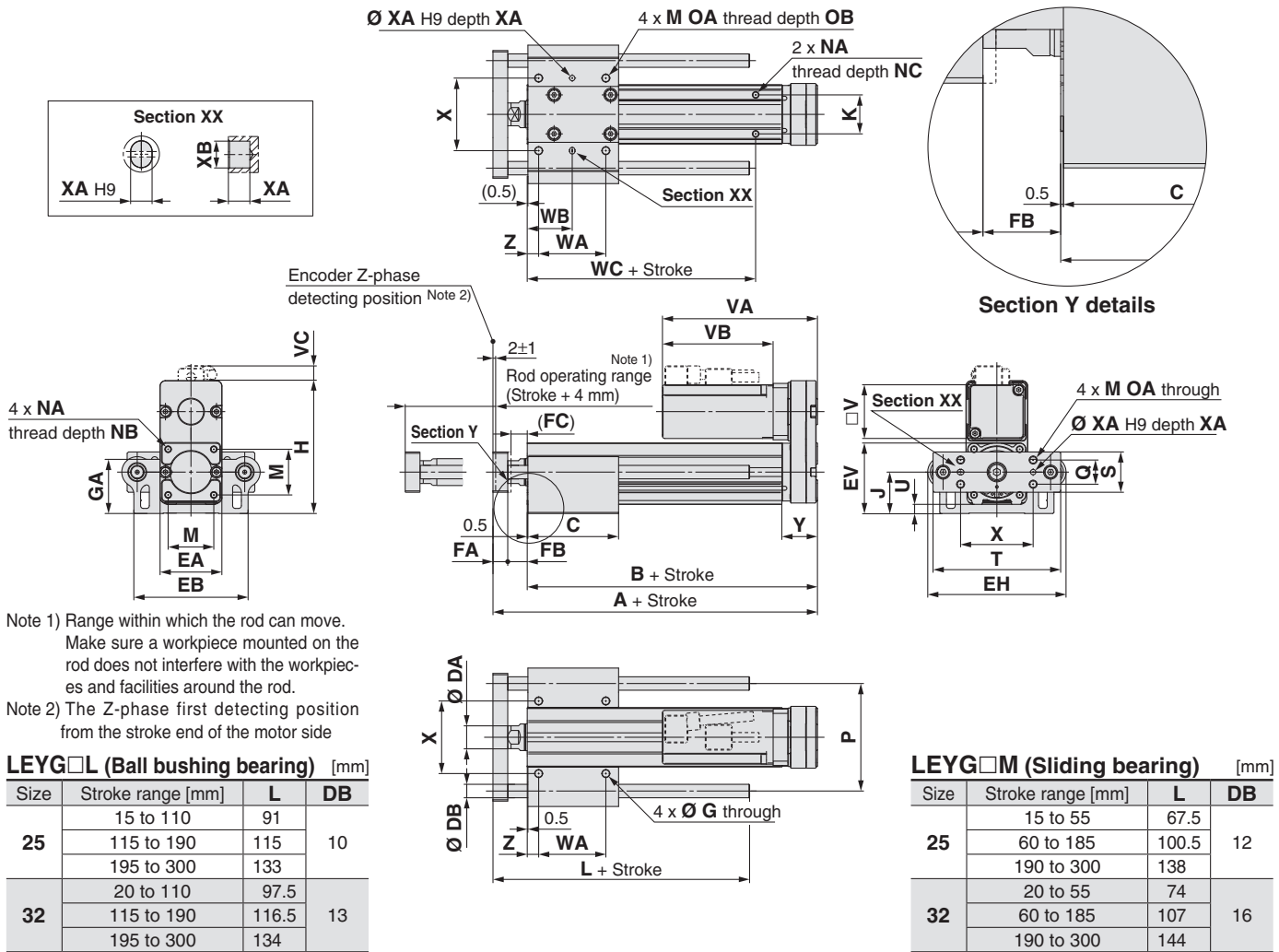

LEYG□M, LEYG□L Common

Size	Stroke range [mm]	A	B	C	DA	EA	EB	EH	EV	FA	FB	FC	G	GA	H	J	K	M	NA	NB	NC
25	15 to 35	141.5	116	50	20	46	85	103	52.3	11	14.5	12.5	5.4	40.3	98.8	30.8	29	34	M5 x 0.8	8	6.5
	40 to 100			67.5																	
	105 to 120			84.5																	
	125 to 200			102																	
32	20 to 35	160.5	130	55	25	60	101	123	63.8	12	18.5	16.5	5.4	50.3	125.8	38.3	30	40	M6 x 1.0	10	8.5
	40 to 100			68																	
	105 to 120			85																	
	125 to 200			102																	

Size	Stroke range [mm]	OA	OB	P	Q	S	T	U	V	WA	WB	WC	X	XA	XB	Y	Z
25	15 to 35	M6 x 1.0	12	80	18	30	95	6.8	40	35	26	70	54	4	5	26.5	8.5
	40 to 100									50	33.5						
	105 to 120									70	43.5	95					
	125 to 200									85	51						
32	20 to 35	M6 x 1.0	12	95	28	40	117	7.3	60	40	28.5	75	64	5	6	34	8.5
	40 to 100									50	33.5						
	105 to 120									70	43.5	105					
	125 to 200									85	51						

Size	Without lock			With lock		
	VA	VB	VC	VA	VB	VC
25	115.5	82.5	11	160.5	127.5	11
32	120	80	14	160	120	14

Series LEYG

AC Servo Motor

Support Block

Guide for support block application

When the stroke exceeds 100 mm and the mounting orientation is horizontal, the body will be bent. Mounting the support block is recommended. (Please order it separately from the models shown below.)

Support Block Model

LEYG-S 025

• Size

025	For size 25
032	For size 32

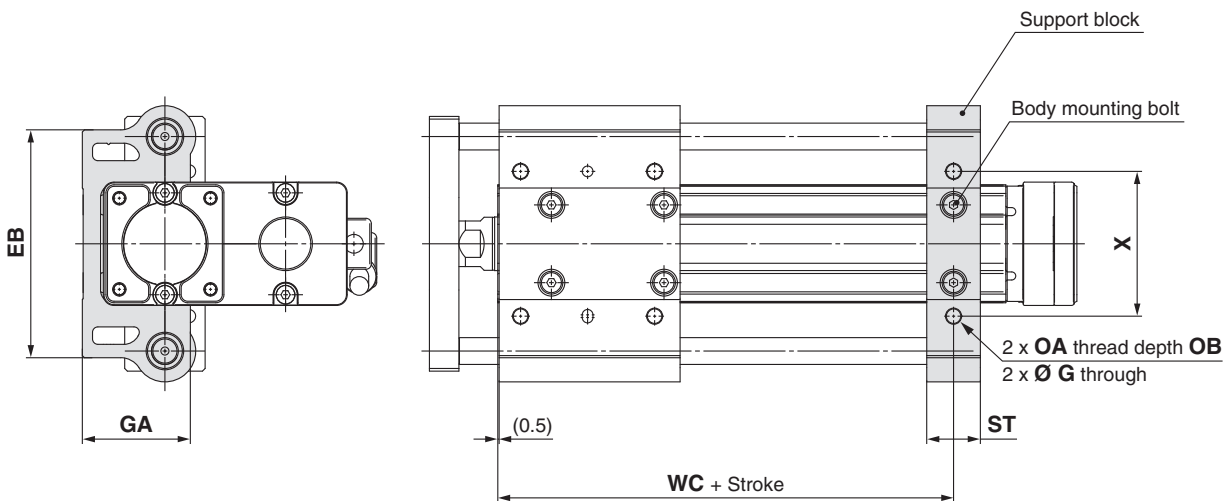
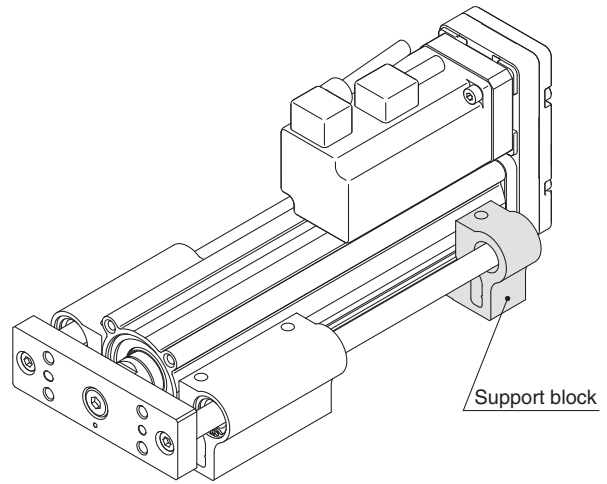

⚠ Caution

Do not install the body using only a support block. The support block should be used only for support.

[mm]										
Size	Model	Stroke range	EB	G	GA	OA	OB	ST	WC	X
25	LEYG-S025	15 to 100	85	5.4	40.3	M6 x 1.0	12	20	70	54
		105 to 300							95	
32	LEYG-S032	20 to 100	101	5.4	50.3	M6 x 1.0	12	22	75	64
		105 to 300							105	

* Two body mounting bolts are included with the support block.

Solid State Auto Switch Direct Mounting Style D-M9N(V)/D-M9P(V)/D-M9B(V)



RoHS

Refer to SMC website for details about products conforming to the international standards.

Auto Switch Specifications

PLC: Programmable Logic Controller

D-M9□, D-M9□V (With indicator light)						
Auto switch model	D-M9N	D-M9NV	D-M9P	D-M9PV	D-M9B	D-M9BV
Electrical entry	In-line	Perpendicular	In-line	Perpendicular	In-line	Perpendicular
Wiring type	3-wire				2-wire	
Output type	NPN		PNP		—	
Applicable load	IC circuit, Relay, PLC				24 VDC relay, PLC	
Power supply voltage	5, 12, 24 VDC (4.5 to 28 V)				—	
Current consumption	10 mA or less				—	
Load voltage	28 VDC or less		—		24 VDC (10 to 28 VDC)	
Load current	40 mA or less				2.5 to 40 mA	
Internal voltage drop	0.8 V or less at 10 mA (2 V or less at 40 mA)				4 V or less	
Leakage current	100 μA or less at 24 VDC				0.8 mA or less	
Indicator light	Red LED lights up when turned ON.					
Standards	CE marking, RoHS					

Oilproof Heavy-duty Lead Wire Specifications

Auto switch model	D-M9N□	D-M9P□	D-M9B□
Sheath	Outside diameter [mm]		
	2.7 x 3.2 (ellipse)		
Insulator	Number of cores		
	3 cores (Brown/Blue/Black)		2 cores (Brown/Blue)
Conductor	Outside diameter [mm]		
	Ø 0.9		
	Effective area [mm ²]		
	0.15		
	Strand diameter [mm]		
	Ø 0.05		
Minimum bending radius [mm] (Reference value)			
20			

Note 1) Refer to the Best Pneumatics No. 2 for solid state auto switch common specifications.
Note 2) Refer to the Best Pneumatics No. 2 for lead wire lengths.

Weight

[g]

Auto switch model	D-M9N(V)	D-M9P(V)	D-M9B(V)
Lead wire length	0.5 m (—)	8	7
	1 m (M)	14	13
	3 m (L)	41	38
	5 m (Z)	68	63

Grommet

- 2-wire load current is reduced (2.5 to 40 mA).
- Flexibility is 1.5 times greater than the conventional model (SMC comparison).
- Using flexible cable as standard.



Caution

Precautions

Fix the auto switch with the existing screw installed on the auto switch body. The auto switch may be damaged if a screw other than the one supplied is used.

Dimensions

[mm]

D-M9□

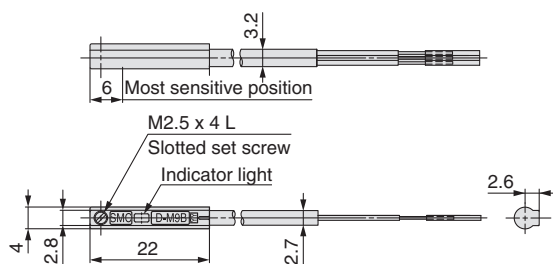

D-M9□V

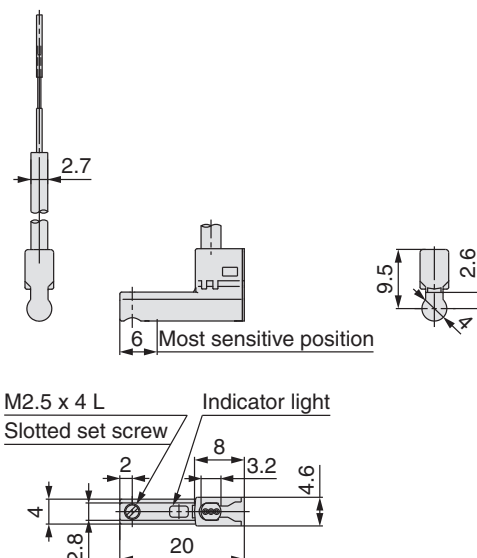

Model Selection
LEY
LEYG
LECA6
LECP6
LEC-G
LECP1
LECPA
JXC□1
JXC7□□□□□□□□
AC Servo Motor
LEY
LEYG
LECS□
LECS-T
LECY□
Specific Product Precautions

2-Colour Indication Solid State Auto Switch Direct Mounting Style D-M9NW(V)/D-M9PW(V)/D-M9BW(V)



Refer to SMC website for details about products conforming to the international standards.

Auto Switch Specifications

PLC: Programmable Logic Controller

D-M9□W, D-M9□WV (With indicator light)						
Auto switch model	D-M9NW	D-M9NWV	D-M9PW	D-M9PWV	D-M9BW	D-M9BWV
Electrical entry	In-line	Perpendicular	In-line	Perpendicular	In-line	Perpendicular
Wiring type	3-wire				2-wire	
Output type	NPN		PNP		—	
Applicable load	IC circuit, Relay, PLC				24 VDC relay, PLC	
Power supply voltage	5, 12, 24 VDC (4.5 to 28 V)				—	
Current consumption	10 mA or less				—	
Load voltage	28 VDC or less		—		24 VDC (10 to 28 VDC)	
Load current	40 mA or less				2.5 to 40 mA	
Internal voltage drop	0.8 V or less at 10 mA (2 V or less at 40 mA)				4 V or less	
Leakage current	100 μA or less at 24 VDC				0.8 mA or less	
Indicator light	Operating range Red LED lights up. Optimum operating range Green LED lights up.					
Standards	CE marking, RoHS					

Grommet

- 2-wire load current is reduced (2.5 to 40 mA).
- Flexibility is 1.5 times greater than the conventional model (SMC comparison).
- Using flexible cable as standard.
- The optimum operating range can be determined by the colour of the light. (Red → Green ← Red)



Caution

Precautions

Fix the auto switch with the existing screw installed on the auto switch body. The auto switch may be damaged if a screw other than the one supplied is used.

Oilproof Flexible Heavy-duty Lead Wire Specifications

Auto switch model		D-M9NW□	D-M9PW□	D-M9BW□
Sheath	Outside diameter [mm]	2.7 x 3.2 (ellipse)		
Insulator	Number of cores	3 cores (Brown/Blue/Black)		2 cores (Brown/Blue)
	Outside diameter [mm]	Ø 0.9		
Conductor	Effective area [mm ²]	0.15		
	Strand diameter [mm]	Ø 0.05		
Minimum bending radius [mm] (Reference value)		20		

Note 1) Refer to the Best Pneumatics No. 2 for solid state auto switch common specifications.
Note 2) Refer to the Best Pneumatics No. 2 for lead wire lengths.

Weight

[g]

Auto switch model		D-M9NW(V)	D-M9PW(V)	D-M9BW(V)
Lead wire length	0.5 m (—)	8	7	7
	1 m (M)	14	13	13
	3 m (L)	41	38	38
	5 m (Z)	68	63	63

Dimensions

[mm]

D-M9□W

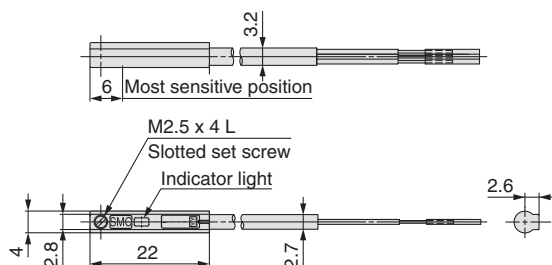

D-M9□WV

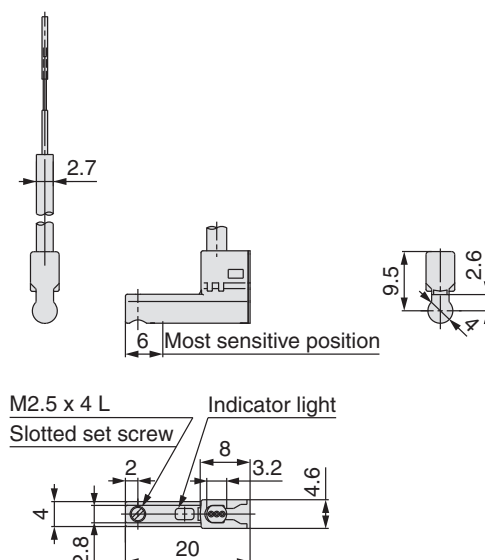



Series LEY/LEYG Electric Actuators/ Specific Product Precautions 1

Be sure to read this before handling. For Safety Instructions and Electric Actuator Precautions, refer to “Handling Precautions for SMC Products” and the Operation Manual on SMC website, <http://www.smc.eu>

Design/Selection

Warning

- Do not apply a load in excess of the operating limit.**
Select a suitable actuator by work load and allowable lateral load on the rod end. If the product is used outside of the operating limit, the eccentric load applied to the piston rod will be excessive and have adverse effects such as creating play on the sliding parts of the piston rod, degrading accuracy and shortening the life of the product.
- Do not use the product in applications where excessive external force or impact force is applied to it.**
This can cause failure.
- When used as a stopper, select the LEYG series “Sliding bearing” for a stroke of 30 mm or less.**
- When used as a stopper, fix the main body with a guide attachment (“Top mounting” or “Bottom mounting”).**
If the end of the actuator is used to fix the main body (end mounting), the excessive load acts on the actuator, which adversely affects the operation and life of the product.

Handling

Caution

- When the pushing operation is used, be sure to set to “Torque control mode”, and use within the specified pushing speed range for each series.**
Do not allow the piston rod to hit the workpiece and end of the stroke in the “Position control mode”, “Speed control mode” or “Positioning mode”. The lead screw, bearing and internal stopper may be damaged and lead to malfunction.
- When operating with “Torque control mode”, the value of the internal torque limit or the external torque limit (LECY) should be set to 90 % or less. (150 % or less only for the LEY63)**
It may lead to damage and malfunction.
- The forward/reverse torque limit is set to 800 % as default.**
When the product is operated with a smaller value than 300 %, acceleration when driving can decrease. Set the value after confirming the actual device to be used.
- The maximum speed of this actuator is affected by the product stroke.**
Check the model selection section of the catalogue.
- Do not apply a load, impact or resistance in addition to the transferred load during return to origin.**
Additional force will cause the displacement of the origin position.
- Do not scratch or dent the sliding parts of the piston rod, by striking or attaching objects.**
The piston rod and guide rod are manufactured to precise tolerances, even a slight deformation may cause malfunction.
- When an external guide is used, connect it in such a way that no impact or load is applied to it.**
Use a freely moving connector (such as a floating joint).
- Do not operate by fixing the piston rod and moving the actuator body.**
Excessive load will be applied to the piston rod, leading to damage to the actuator and reduced the life of the product.

Handling

Caution

- When an actuator is operated with one end fixed and the other free (ends tapped (standard), flange type), a bending moment may act on the actuator due to vibration generated at the stroke end, which can damage the actuator. In such a case, install a mounting bracket to suppress the vibration of the actuator body or reduce the speed so that the actuator does not vibrate.**
Also, use a mounting bracket when moving the actuator body or when a long stroke actuator is mounted horizontally and fixed at one end.
- Avoid using the electric actuator in such a way that rotational torque would be applied to the piston rod.**
This may cause deformation of the non-rotating guide, abnormal responses of the auto switch, play in the internal guide or an increase in the sliding resistance. Refer to the table below for the approximate values of the allowable range of rotational torque.

Allowable rotational torque [N·m] or less	LEY25□	LEY32	LEY63
	1.1	1.4	2.8

When screwing in a bracket or nut to the end of the piston rod, hold the flats of the rod end with a wrench (the piston rod should be fully retracted). Do not apply tightening torque to the non-rotating mechanism.

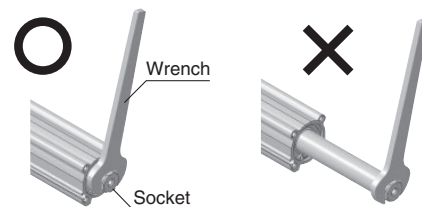

- When using auto switch with the guide rod type LEYG series, the following limits will be in effect. Please select the product while paying attention to this.**
 - Insert the auto switch from the front side with rod (plate) sticking out.
 - The auto switches with perpendicular electrical entry cannot be used.
 - For the parts hidden behind the guide attachment (Rod stick out side), the auto switch cannot be fixed.
 - Consult with SMC when using auto switch on the rod stick out side.

Enclosure

IP-□□

First characteristic numeral • Second characteristic numeral

- First Characteristics:**
Degrees of protection against solid foreign objects

0	Non-protected
1	Protected against solid foreign objects of 50 mmØ and greater
2	Protected against solid foreign objects of 12 mmØ and greater
3	Protected against solid foreign objects of 2.5 mmØ and greater
4	Protected against solid foreign objects of 1.0 mmØ and greater
5	Dust-protected
6	Dust-tight

Model Selection

Servo Motor (24 VDC)/Step Motor (Servo/24 VDC)

LEY

LEYG

LECA6
LECP6

LEC-G

LECP1

LECPA

JXC□1

JXC7/3/3/3/2/3/3

LEY

AC Servo Motor

LEYG

LECS□

LECS-T

LECY□

Specific Product Precautions



Series LEY/LEYG Electric Actuators/ Specific Product Precautions 2

Be sure to read this before handling. For Safety Instructions and Electric Actuator Precautions, refer to “Handling Precautions for SMC Products” and the Operation Manual on SMC website, <http://www.smc.eu>

Enclosure

• Second Characteristics: Degrees of protection against water

0	Non-protected	—
1	Protected against vertically falling water drops	Drip-proof type 1
2	Protected against vertically falling water drops when enclosure tilted up to 15°	Drip-proof type 2
3	Protected against rainfall when enclosure tilted up to 60°	Rainproof type
4	Protected against splashing water	Splashproof type
5	Protected against water jets	Water-jet-proof type
6	Protected against powerful water jets	Powerful water-jet-proof type
7	Protected against the effects of temporary immersion in water	Immersible type
8	Protected against the effects of continuous immersion in water	Submersible type

Example) IP65: Dust-tight, Water-jet-proof type

“Water-jet-proof type” means that no water intrudes inside an equipment that could hinder from operating normally by means of applying water for 3 minutes in the prescribed manner. Take appropriate protection measures, since a device is not usable in an environment where a droplet of water is splashed constantly.

Mounting

⚠ Caution

- When mounting workpieces or jigs to the piston rod end, hold the flats of the piston rod end with a wrench so that the piston rod does not rotate. The bolt should be tightened within the specified torque range.

This may cause abnormal responses of the auto switch, play in the internal guide or an increase in the sliding resistance.

- When mounting the product and/or a workpiece, tighten the mounting screws within the specified torque range.

Tightening the screws with a higher torque than recommended may cause a malfunction, whilst the tightening with a lower torque can cause the displacement of the mounting position or in extreme conditions the actuator could become detached from its mounting position.

<Series LEY>

Workpiece fixed/Rod end female thread

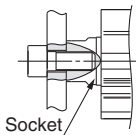

Model	Bolt	Max. tightening torque [N·m]	Max. screw-in depth [mm]	End socket width across flats [mm]
LEY25	M8 x 1.25	12.5	13	17
LEY32	M8 x 1.25	12.5	13	22
LEY63	M16 x 2	106	21	36

Workpiece fixed/Rod end male thread

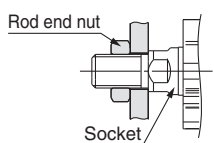

Model	Bolt	Max. tightening torque [N·m]	Effective thread length [mm]	End socket width across flats [mm]
LEY25	M14 x 1.5	50	20.5	17
LEY32	M14 x 1.5	50	20.5	22
LEY63	M18 x 1.5	97	26	36

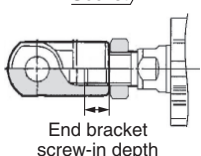

Model	Rod end nut		End bracket screw-in depth [mm]
	Width across flats [mm]	Length [mm]	
LEY25	22	8	14
LEY32	22	8	14
LEY63	27	11	18

* Rod end nut is an accessory.

Mounting

⚠ Caution

Body fixed/Body bottom tapped style (When “Body bottom tapped” is selected.)

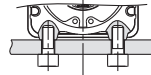

Model	Bolt	Max. tightening torque [N·m]	Max. screw-in depth [mm]
LEY25	M5 x 0.8	3.0	6.5
LEY32	M6 x 1.0	5.2	8.8
LEY63	M8 x 1.25	12.5	10

Body fixed/Rod side/Head side tapped style

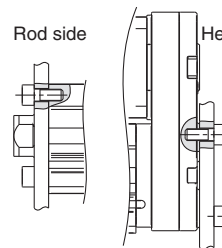

Model	Bolt	Max. tightening torque [N·m]	Max. screw-in depth [mm]
LEY25	M5 x 0.8	3.0	8
LEY32	M6 x 1.0	5.2	10
LEY63	M8 x 1.25	12.5	16

* Except the LEY□D.

<Series LEYG>

Workpiece fixed/Plate tapped style

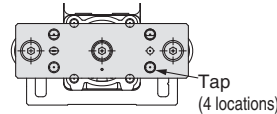

Model	Bolt	Max. tightening torque [N·m]	Max. screw-in depth [mm]
LEYG25 ^M _L	M6 x 1.0	5.2	11
LEYG32 ^M _L	M6 x 1.0	5.2	12

Body fixed/Top mounting

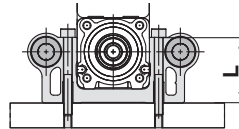

Model	Bolt	Max. tightening torque [N·m]	Length: L [mm]
LEYG25 ^M _L	M5 x 0.8	3.0	40.3
LEYG32 ^M _L	M5 x 0.8	3.0	50.3

Body fixed/Bottom mounting

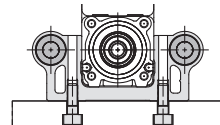

Model	Bolt	Max. tightening torque [N·m]	Max. screw-in depth [mm]
LEYG25 ^M _L	M6 x 1.0	5.2	12
LEYG32 ^M _L	M6 x 1.0	5.2	12

Body fixed/Head side tapped style

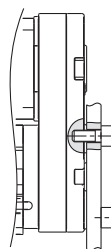

Model	Bolt	Max. tightening torque [N·m]	Max. screw-in depth [mm]
LEYG25 ^M _L	M5 x 0.8	3.0	8
LEYG32 ^M _L	M6 x 1.0	5.2	10



Series LEY/LEYG

Electric Actuators/ Specific Product Precautions 3

Be sure to read this before handling. For Safety Instructions and Electric Actuator Precautions, refer to “Handling Precautions for SMC Products” and the Operation Manual on SMC website, <http://www.smc.eu>

Mounting

Caution

3. Keep the flatness of the mounting surface within the following ranges when mounting the actuator body and workpiece.

Unevenness of a workpiece or base mounted on the body of the product may cause an increase in the sliding resistance.

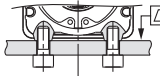
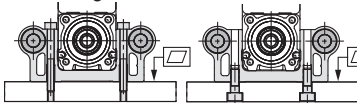
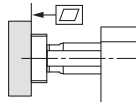
Model	Mounting position	Flatness
LEY□	Body/Body bottom 	0.1 mm or less
LEYG□	Bottom mounting 	0.02 mm or less
	Workpiece/Plate mounting 	0.02 mm or less

Maintenance

Warning

1. Ensure that the power supply is stopped and the workpiece is removed before starting maintenance work or replacement of the product.

• Maintenance frequency

Perform maintenance according to the table below.

Frequency	Appearance check	Belt check
Inspection before daily operation	○	—
Inspection every 6 months/250 km/5 million cycles*	○	○

* Select whichever comes sooner.

• Items for visual appearance check

- Loose set screws, Abnormal dirt
- Check of flaw and cable joint
- Vibration, Noise

• Items for belt check

Stop operation immediately and replace the belt when belt appear to be below. Further, ensure your operating environment and conditions satisfy the requirements specified for the product.

a. Tooth shape canvas is worn out

Canvas fiber becomes fuzzy. Rubber is removed and the fiber becomes whitish. Lines of fibers become unclear.

b. Peeling off or wearing of the side of the belt

Belt corner becomes round and frayed thread sticks out.

c. Belt partially cut

Belt is partially cut. Foreign matter caught in teeth other than cut part causes flaw.

d. Vertical line of belt teeth

Flaw which is made when the belt runs on the flange.

e. Rubber back of the belt is softened and sticky

f. Crack on the back of the belt

Model Selection

Servo Motor (24 VDC)/Step Motor (Servo/24 VDC)
LEY
LEYG

LECA6
LECP6

LEC-G

LECP1

LECPA

JXC□1

JXC7□□□□□□□□

LEY

AC Servo Motor
LEYG

LECS□

LECS-T

LECY□

Specific Product Precautions

MECHATROLINK Compatible AC Servo Motor Driver

Absolute Type Series *LECYM*

MECHATROLINK-II Type



Absolute Type Series *LECYU*

MECHATROLINK-III Type



Model Selection

Servo Motor (24 VDC) (Step Motor (Servo/24 VDC))
LEYG
LEY

LECA6
LECP6

LEC-G

LECP1

LECPA

JXC□1

JXC7□□□□□□□□

AC Servo Motor
LEY

LEYG

LECS□

LECS-T

LECY□

Specific Product Precautions

MECHATROLINK Compatible

AC Servo Motor Driver

Absolute Type

Series **LECYM/LECYU**

(MECHATROLINK-II Type)

(MECHATROLINK-III Type)



How to Order

Driver

LECYM 2 -

Driver type

M	MECHATROLINK-II type (For absolute encoder)
U	MECHATROLINK-III type (For absolute encoder)

Power supply voltage

2	200 to 230 VAC, 50/60 Hz
----------	--------------------------

Compatible motor type

Symbol	Type	Capacity	Encoder
V5	AC servo motor (V6 *2)	100 W	Absolute
V7	AC servo motor (V7 *2)	200 W	
V8	AC servo motor (V8 *2)	400 W	

*1 If the I/O signal connector (CN 1) is required, order the part number "LECYNA" separately.

*2 The symbol shows the motor type (actuator).



LECYM LECYU

Dimensions

MECHATROLINK-II type

LECYM2-V

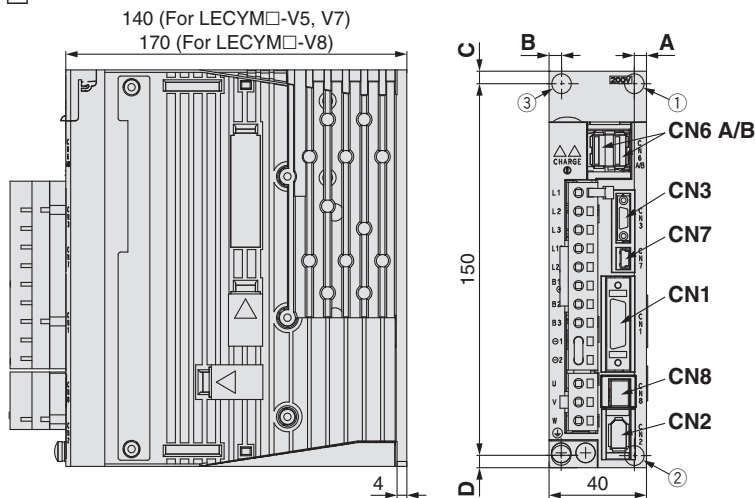

Connector name	Description
CN1	I/O signal connector
CN2	Encoder connector
CN3 (Note)	Digital operator connector
CN6A	MECHATROLINK-II communication connector
CN6B	MECHATROLINK-II communication connector
CN7	PC connector
CN8	Safety connector

Note) Digital operator is JUSP-OP05A-1-E manufactured by YASKAWA Electric Corporation. When using the digital operator, it should be provided by the customer.

Motor capacity	Hole position	Mounting dimensions				Mounting hole
		A	B	C	D	
V5 (100 W)	①②	5	—	5	5	Ø 5
V7 (200 W)	①②	5	—	5	5	
V8 (400 W)	②③	5	5	5	5	

* The mounting hole position varies depending on the motor capacity.

MECHATROLINK-III type

LECYU2-V

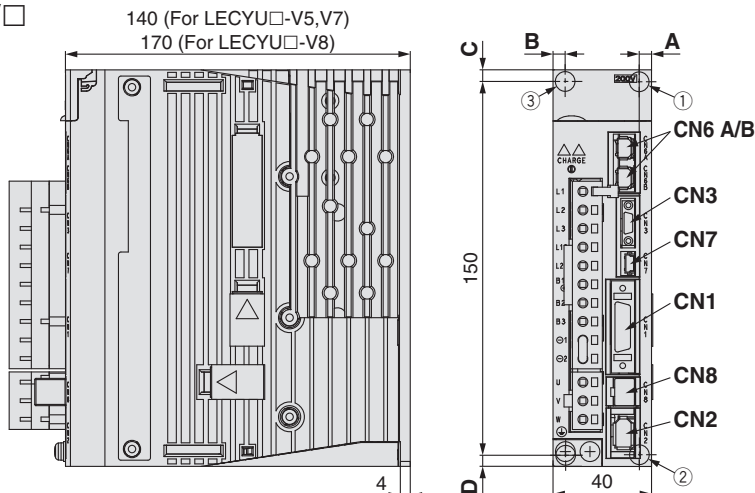

Connector name	Description
CN1	I/O signal connector
CN2	Encoder connector
CN3 (Note)	Digital operator connector
CN6A	MECHATROLINK-III communication connector
CN6B	MECHATROLINK-III communication connector
CN7	PC connector
CN8	Safety connector

Note) Digital operator is JUSP-OP05A-1-E manufactured by YASKAWA Electric Corporation. When using the digital operator, it should be provided by the customer.

Motor capacity	Hole position	Mounting dimensions				Mounting hole
		A	B	C	D	
V5 (100 W)	①②	5	—	5	5	Ø 5
V7 (200 W)	①②	5	—	5	5	
V8 (400 W)	②③	5	5	5	5	

* The mounting hole position varies depending on the motor capacity.

Specifications

MECHATROLINK-II Type

Model		LECYM2-V5	LECYM2-V7	LECYM2-V8
Compatible motor capacity [W]		100	200	400
Compatible encoder		Absolute 20-bit encoder (Resolution: 1048576 p/rev)		
Main circuit power supply	Power voltage [V]	Three phase 200 to 230 VAC (50/60 Hz)		
	Allowable voltage fluctuation [V]	Three phase 170 to 253 VAC		
Control power supply	Power voltage [V]	Single phase 200 to 230 VAC (50/60 Hz)		
	Allowable voltage fluctuation [V]	Single phase 170 to 253 VAC		
Power supply capacity (at rated output) [A]		0.91	1.6	2.8
Input circuit		NPN (Sink circuit)/PNP (Source circuit)		
Parallel input (7 inputs)	Number of optional allocations	7 inputs	[Initial allocation] · Homing deceleration switch (/DEC) · External latch (/EXT 1 to 3) · Forward run prohibited (P-OT), reverse run prohibited (N-OT) [Can be allocated by setting the parameters.] · Forward external torque limit (/P-CL), reverse external torque limit (/N-CL) Signal allocations can be performed, and positive and negative logic can be changed.	
Parallel output (4 outputs)	Number of fixed allocations	1 output	· Servo alarm (ALM)	
	Number of optional allocations	3 outputs	[Initial allocation] · Lock (/BK) [Can be allocated by setting the parameters.] · Positioning completion (/COIN) · Speed limit detection (/VLT) · Speed coincidence detection (/V-CMP) · Rotation detection (/TGON) · Warning (/WARN) · Servo ready (/S-RDY) · Near (/NEAR) · Torque limit detection (/CLT) Signal allocations can be performed, and positive and negative logic can be changed.	
MECHATROLINK communication	Communication protocol	MECHATROLINK-II		
	Station address	41H to 5FH		
	Communication speed	10 Mbps		
	Communication cycle	250 μs, 0.5 ms to 4 ms (Multiples of 0.5 ms)		
	Number of transmission bytes	17 bytes, 32 bytes		
	Max. number of stations	30		
	Cable length	Overall cable length: 50 m or less, Cable length between the stations: 0.5 m or more		
Command method	Control method	Position, speed, or torque control with MECHATROLINK-II communication		
	Command input	MECHATROLINK-II command (Motion, data setting, monitoring or adjustment)		
Function	Gain adjustment	Tuning-less/Advanced autotuning/One-parameter tuning		
	Communication setting	USB communication, RS-422 communication		
	Torque limit	Internal torque limit, external torque limit, and torque limit by analogue command		
	Encoder output	Phase A, B, Z: Line driver output		
	Emergency stop	CN8 Safety function		
	Overtravel	Dynamic brake stop, deceleration to a stop, or free run to a stop at P-OT or N-OT		
Alarm	Alarm signal, MECHATROLINK-II command			
Operating temperature range [°C]		0 to 55 (No freezing)		
Operating humidity range [%RH]		90 or less (No condensation)		
Storage temperature range [°C]		-20 to 85 (No freezing)		
Storage humidity range [%RH]		90 or less (No condensation)		
Insulation resistance [MΩ]		10 MΩ (500 VDC)		
Weight [g]		900		1000

Model Selection

LECY

LEYG

LECA6
LECP6

LECG

LECP1

LECPA

JXC□1

JXC7□□□□□□□□

LECY

LEYG

LECS□

LECS-T

LECY□

Specific Product Precautions

AC Servo Motor

Servo Motor (24 VDC)/Step Motor (Servo/24 VDC)

Specifications

MECHATROLINK-III Type

Model		LECYU2-V5	LECYU2-V7	LECYU2-V8
Compatible motor capacity [W]		100	200	400
Compatible encoder		Absolute 20-bit encoder (Resolution: 1048576 p/rev)		
Main circuit power supply	Power voltage [V]	Three phase 200 to 230 VAC (50/60 Hz)		
	Allowable voltage fluctuation [V]	Three phase 170 to 253 VAC		
Control power supply	Power voltage [V]	Single phase 200 to 230 VAC (50/60 Hz)		
	Allowable voltage fluctuation [V]	Single phase 170 to 253 VAC		
Power supply capacity (at rated output) [A]		0.91	1.6	2.8
Input circuit		NPN (Sink circuit)/PNP (Source circuit)		
Parallel input (7 inputs)	Number of optional allocations	7 inputs	[Initial allocation] · Homing deceleration switch (/DEC) · External latch (/EXT 1 to 3) · Forward run prohibited (P-OT), reverse run prohibited (N-OT) [Can be allocated by setting the parameters.] · Forward external torque limit (/P-CL), reverse external torque limit (/N-CL) Signal allocations can be performed, and positive and negative logic can be changed.	
Parallel output (4 outputs)	Number of fixed allocations	1 output	· Servo alarm (ALM)	
	Number of optional allocations	3 outputs	[Initial allocation] · Lock (/BK) [Can be allocated by setting the parameters.] · Positioning completion (/COIN) · Speed limit detection (/VLT) · Speed coincidence detection (/V-CMP) · Rotation detection (/TGON) · Warning (/WARN) · Servo ready (/S-RDY) · Near (/NEAR) · Torque limit detection (/CLT) Signal allocations can be performed, and positive and negative logic can be changed.	
MECHATROLINK communication	Communication protocol	MECHATROLINK-III		
	Station address	03H to EFH		
	Communication speed	100 Mbps		
	Communication cycle	125 μs, 250 μs, 500 μs, 750 μs, 1 ms to 4 ms (Multiples of 0.5 ms)		
	Number of transmission bytes	16 bytes, 32 bytes, 48 bytes,		
	Max. number of stations	62		
	Cable length	Cable length between the stations: 0.5 m or more, 75 m or less		
Command method	Control method	Position, speed, or torque control with MECHATROLINK-III communication		
	Command input	MECHATROLINK-III command (Motion, data setting, monitoring or adjustment)		
Function	Gain adjustment	Tuning-less/Advanced autotuning/One-parameter tuning		
	Communication setting	USB communication, RS-422 communication		
	Torque limit	Internal torque limit, external torque limit, and torque limit by analogue command		
	Encoder output	Phase A, B, Z: Line driver output		
	Emergency stop	CN8 Safety function		
	Overtravel	Dynamic brake stop, deceleration to a stop, or free run to a stop at P-OT or N-OT		
Alarm	Alarm signal, MECHATROLINK-III command			
Operating temperature range [°C]		0 to 55 (No freezing)		
Operating humidity range [%RH]		90 or less (No condensation)		
Storage temperature range [°C]		-20 to 85 (No freezing)		
Storage humidity range [%RH]		90 or less (No condensation)		
Insulation resistance [MΩ]		10 MΩ (500 VDC)		
Weight [g]		900		1000

Power Supply Wiring Example: LECY□

■ Three phase 200 V LECYM2-□
LECYU2-□

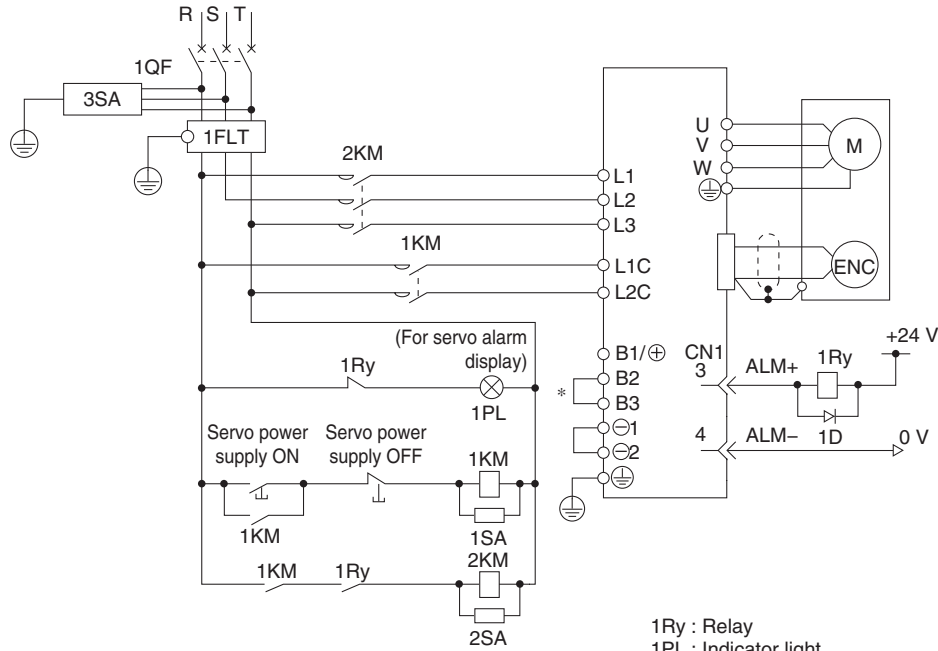

- 1QF : Molded-case circuit breaker
- 1FLT: Noise filter
- 1KM : Magnetic contactor (for control power supply)
- 2KM : Magnetic contactor (for main circuit power supply)
- 1Ry : Relay
- 1PL : Indicator light
- 1SA : Surge absorber
- 2SA : Surge absorber
- 3SA : Surge absorber
- 1D : Flywheel diode

* For the LECY□2-V5, LECY□2-V7 and LECY□2-V8, terminals B2 and B3 are not short-circuited. Do not short-circuit these terminals.

Main Circuit Power Supply Connector * Accessory

Terminal name	Function	Details
L1	Main circuit power supply	Connect the main circuit power supply. Single phase 200 to 230 VAC, 50/60 Hz Connection terminal: L1, L2 Three phase 200 to 230 VAC, 50/60 Hz Connection terminal: L1, L2, L3
L2		
L3		
L1C	Control power supply	Connect the control power supply. Single phase 200 to 230 VAC, 50/60 Hz Connection terminal: L1C, L2C
L2C		
B1/⊕	External regenerative resistor connection terminal	When the regenerative resistor is required, connect it between terminals B1/⊕ and B2.
B2		
B3		
⊖1	Main circuit negative terminal	⊖1 and ⊖2 are connected at shipment.
⊖2		

Motor Connector * Accessory

Terminal name	Function	Details
U	Servo motor power (U)	Connect to motor cable (U, V, W).
V	Servo motor power (V)	
W	Servo motor power (W)	

Power Supply Wire Specifications

Item	Specifications
Applicable wire size	L1, L2, L3, L1C, L2C Single wire, Twisted wire, AWG14 (2.0 mm ²)
Stripped wire length	8 to 9 mm

Main circuit power supply connector

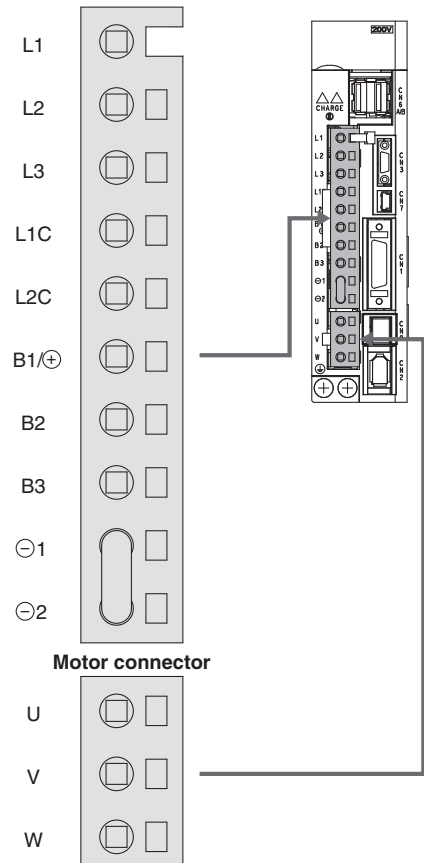

Model Selection

LECY

LEYG

LECA6
LECP6

LEC-G

LECP1

LECPA

JXC□1

JXC73/83/92/93

LECY

LEYG

LECS□

LECS-T

LECY□

Specific Product Precautions

Control Signal Wiring Example: LECYM

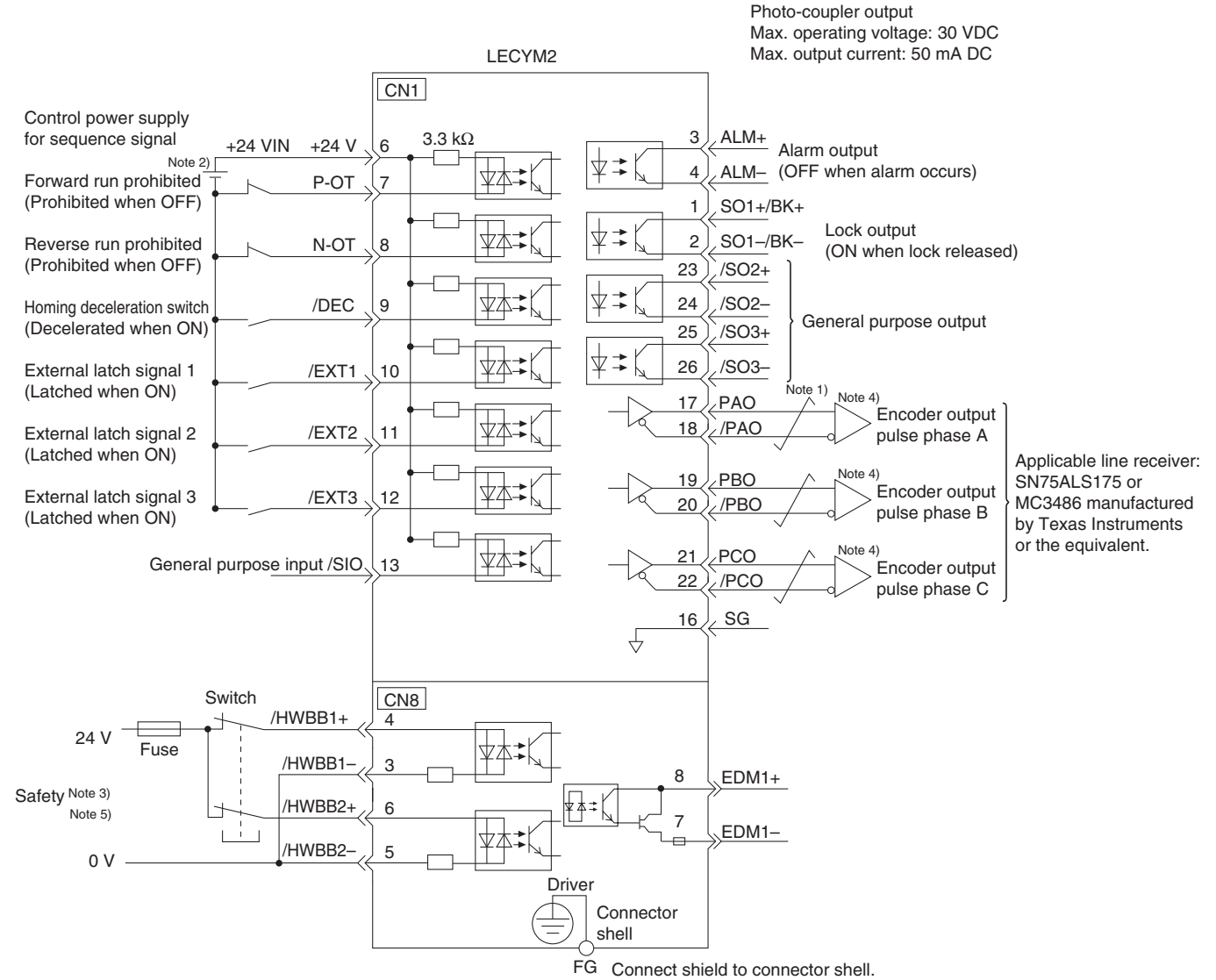

Note 1) $\overline{\text{---}}$ shows twisted-pair wires.

Note 2) The 24 VDC power supply is not included. Use a 24 VDC power supply with double insulation or reinforced insulation.

Note 3) When using the safety function, a safety function device must be connected to the wiring that is necessary to activate the safety function. Otherwise, the servo motor is not turned ON. When not using the safety function, use the driver with the Safety Jumper Connector (provided as an accessory) inserted into the CN8.

Note 4) Always use line receivers to receive the output signals.

* The functions allocated to the input signals /DEC, P-OT, N-OT, /EXT1, /EXT2 and /EXT3, and the output signals /SO1, /SO2 and /SO3 can be changed by setting the parameters.

Note 5) Compatible with the HWBB function (STO function (IEC61800-5-2)).

Control Signal Wiring Example: LECYU

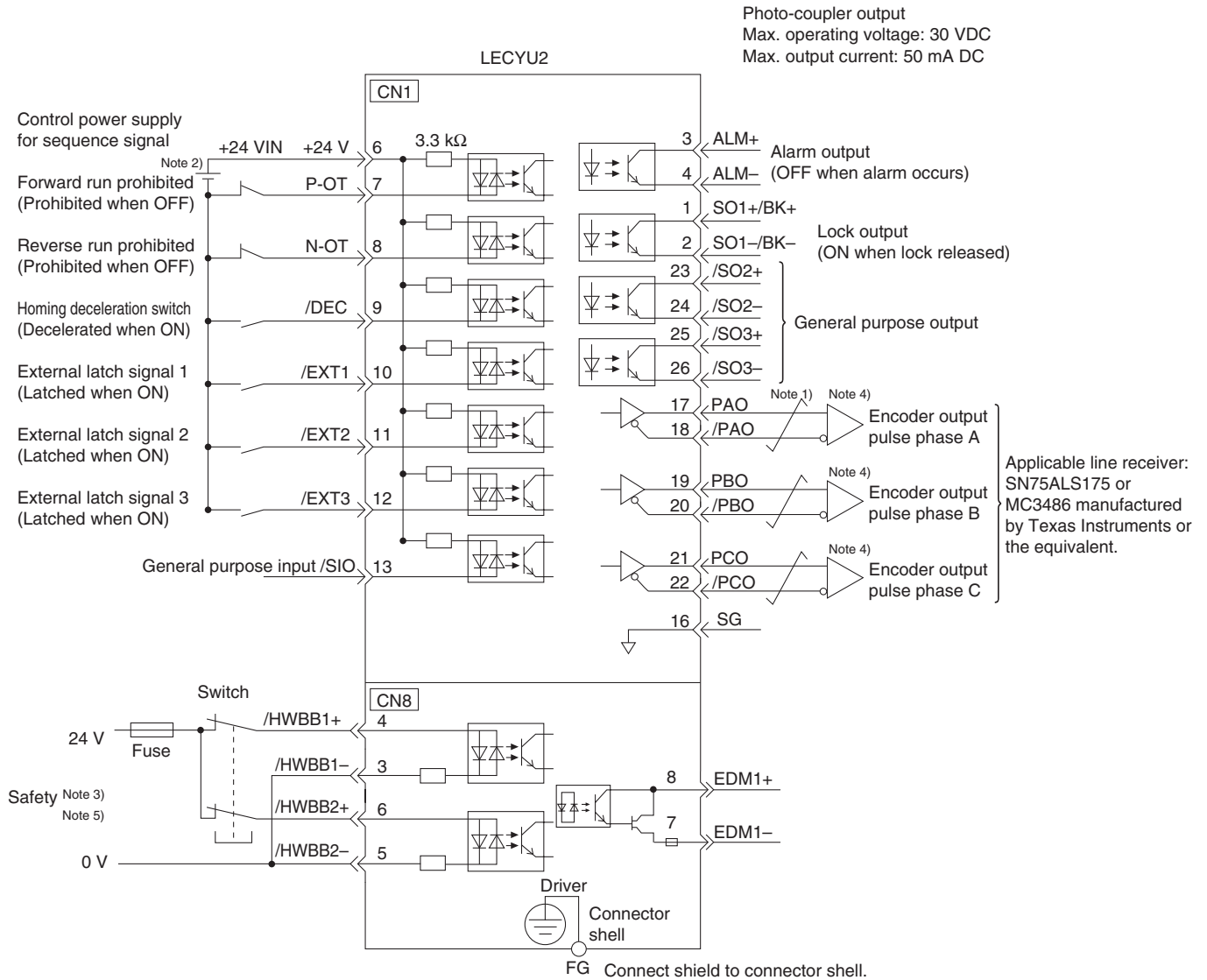

Note 1) $\overline{\text{---}}$ shows twisted-pair wires.

Note 2) The 24 VDC power supply is not included. Use a 24 VDC power supply with double insulation or reinforced insulation.

Note 3) When using the safety function, a safety function device must be connected to the wiring that is necessary to activate the safety function. Otherwise, the servo motor is not turned ON. When not using the safety function, use the driver with the Safety Jumper Connector (provided as an accessory) inserted into the CN8.

Note 4) Always use line receivers to receive the output signals.

* The functions allocated to the input signals /DEC, P-OT, N-OT, /EXT1, /EXT2 and /EXT3, and the output signals /SO1, /SO2 and /SO3 can be changed by setting the parameters.

Note 5) Compatible with the HWBB function (STO function (IEC61800-5-2)).

Series **LECY^M** **U**

Options

Motor cable, Motor cable for lock option, Encoder cable (LECYM/LECYU common)

LE-CY M-S 5 A-5

Motor type

Y	AC servo motor
----------	----------------

Cable description

M	Motor cable
B	Motor cable for lock option
E	Encoder cable (With battery case)

Cable type

S	Standard cable
R	Robotic cable

Motor capacity

5	100 W
7	200/400 W

* For encoder cable, the suffix “-□” (Motor capacity) is not necessary.

Direction of connector

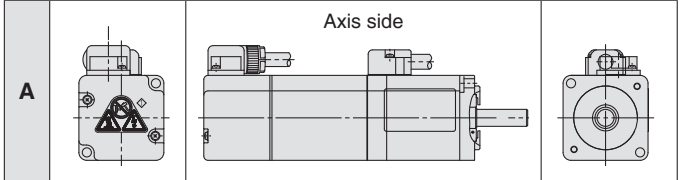

* The cable entry direction is axis side only.

Cable length (L) [m]

3	3
5	5
A	10
C	20

LE-CYM-□□A-□: Motor cable

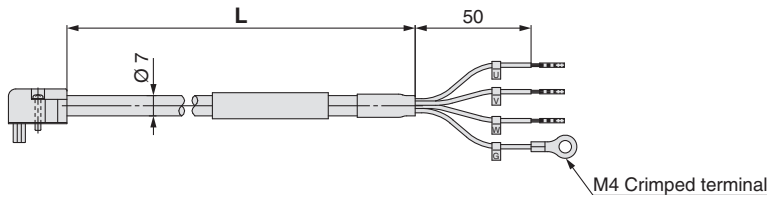

LE-CYB-□□A-□: Motor cable for lock option

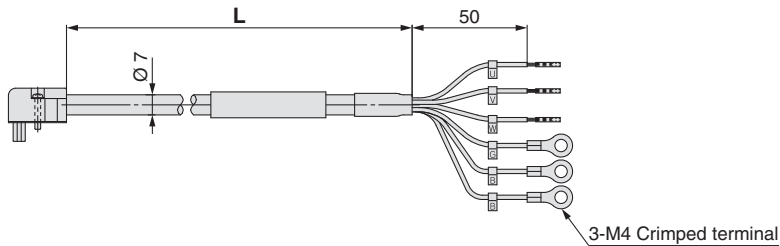

LE-CYE-□□A: Encoder cable

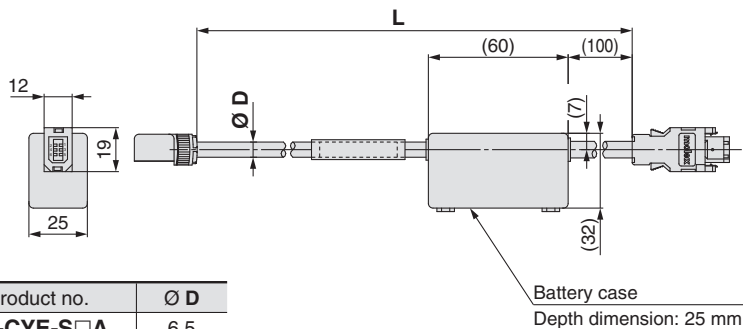

Product no.	Ø D
LE-CYE-S□A	6.5
LE-CYE-R□A	6.8

* LE-CYM-S□A-□ is JZSP-CSM0□-□□-E manufactured by YASKAWA CONTROLS CO., LTD.
 LE-CYB-S□A-□ is JZSP-CSM1□-□□-E manufactured by YASKAWA CONTROLS CO., LTD.
 LE-CYE-S□A is JZSP-CSP05-□□-E manufactured by YASKAWA CONTROLS CO., LTD.
 LE-CYM-R□A-□ is JZSP-CSM2□-□□-E manufactured by YASKAWA CONTROLS CO., LTD.
 LE-CYB-R□A-□ is JZSP-CSM3□-□□-E manufactured by YASKAWA CONTROLS CO., LTD.
 LE-CYE-R□A is JZSP-CSP25-□□-E manufactured by YASKAWA CONTROLS CO., LTD.

Options

I/O connector

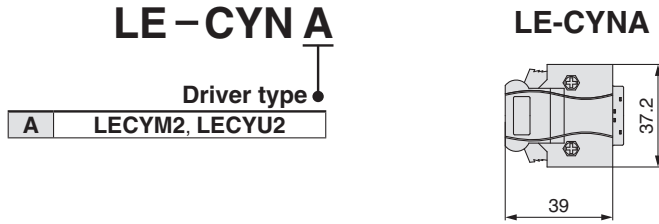

- * LE-CYNA: 10126-3000PE (connector)/10326-52F0-008 (shell kit) manufactured by Sumitomo 3M Limited or equivalent item.
- * Conductor size: AWG24 to 30.

I/O cable

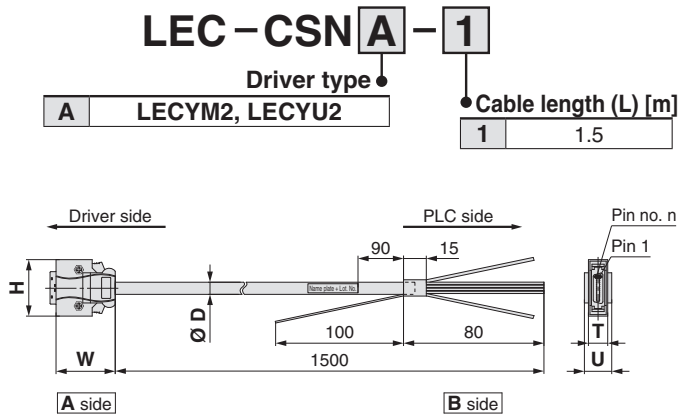

- * LEC-CSNA-1: 10126-3000PE (connector)/10326-52F0-008 (shell kit) manufactured by Sumitomo 3M Limited or equivalent item.
- * Conductor size: AWG24

Wiring

LEC-CSNA-1: Pin no. 1 to 26

Connector pin no.	Pair no. of wire	Insulation colour	Dot mark	Dot colour	Connector pin no.	Pair no. of wire	Insulation colour	Dot mark	Dot colour	Connector pin no.	Pair no. of wire	Insulation colour	Dot mark	Dot colour	
A side	1	Orange	■	Red	A side	11	Orange	■ ■	Red	A side	21	11	Orange	■ ■ ■ ■	Red
	2			Black		12			Black		22			Black	
	3	Light grey	■	Red		13	Light grey	■ ■	Red		23	12	Light grey	■ ■ ■ ■	Red
	4			Black		14			Black		24			Black	
	5	White	■	Red		15	White	■ ■	Red		25	13	White	■ ■ ■ ■	Red
	6			Black		16			Black		26			Black	
	7	Yellow	■	Red		17	Yellow	■ ■	Red						
	8			Black		18			Black						
	9	Pink	■	Red		19	Pink	■ ■	Red						
	10			Black		20			Black						

Cable O.D.

Product no.	Ø D
LEC-CSNA-1	11.1

Dimensions/Pin No.

Product no.	W	H	T	U	Pin no. n
LEC-CSNA-1	39	37.2	12.7	14	14

Model Selection

LECY

LEYG

LECYM2, LECYU2

LECYM2, LECYU2

LECYM2, LECYU2

LECYM2, LECYU2

LECYM2, LECYU2

LECYM2, LECYU2

LECYM2, LECYU2

LECYM2, LECYU2

LECYM2, LECYU2

LECYM2, LECYU2

LECYM2, LECYU2

LECYM2, LECYU2

LECYM2, LECYU2

LECYM2, LECYU2

Series **LECY^M_U**

Options

MECHATROLINK cable type

LEC-CY M - 1

Motor type

Y AC servo motor

Cable description

M	MECHATROLINK-II cable
U	MECHATROLINK-III cable

Cable length (L)

L*	0.2 m
J	0.5 m
1	1 m
3	3 m

* Not available for the MECHATROLINK-II cable.

* LEC-CYM-□ is JEPMC-W6002-□□-E manufactured by YASKAWA CONTROLS CO., LTD.

* LEC-CYU-□ is JEPMC-W6012-□□-E manufactured by YASKAWA CONTROLS CO., LTD.

MECHATROLINK-II cable

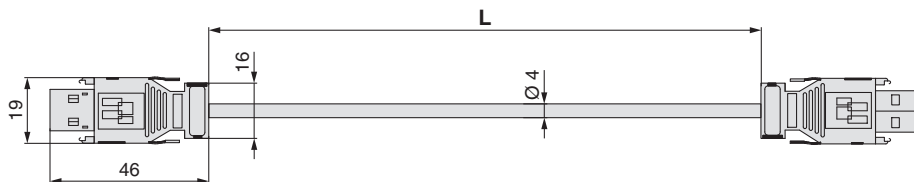

MECHATROLINK-III cable

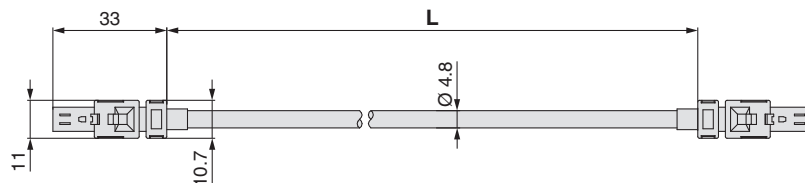

Terminating connector for MECHATROLINK-II

LEC-CYRM

* LEC-CYRM is JEPMC-W6022-E manufactured by YASKAWA CONTROLS CO., LTD.

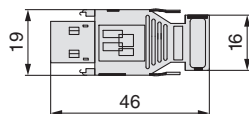

Options

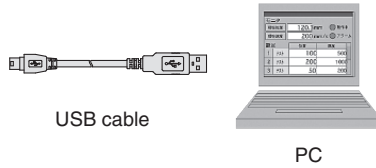
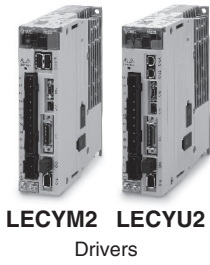

Setup software (SigmaWin+™) (LECYM/LECYU common)

* Please download the SigmaWin+™ via our website.
SigmaWin+™ is a registered trademark or trademark of YASKAWA Electric Corporation.

Adjustment, waveform display, diagnostics, parameter read/write, and test operation can be performed upon a PC.

Compatible PC

When using setup software (SigmaWin+™), use an IBM PC/AT compatible PC that meets the following operating conditions.

Hardware Requirements

Equipment		Setup software (SigmaWin+™)
Note 1) 2) 3) 4) PC	OS	Windows® XP Note 5), Windows Vista®, Windows® 7 (32-bit/64-bit)
	Available HD space	350 MB or more (When the software is installed, 400 MB or more is recommended.)
	Communication interface	Use USB port.
Display	XVGA monitor (1024 x 768 or more, "The small font is used.") 256 colour or more (65536 colour or more is recommended.) The connectable with the above PC	
Keyboard	The connectable with the above PC	
Mouse	The connectable with the above PC	
Printer	The connectable with the above PC	
USB cable	LEC-JZ-CVUSB Note 6)	
Other	Adobe Reader Ver. 5.0 or higher (* Except Ver. 6.0)	

Note 1) Windows, Windows Vista®, Windows® 7 are registered trademarks of Microsoft Corporation in the United States and/or other countries.

Note 2) On some PCs, this software may not run properly.

Note 3) Not compatible with 64-bit Windows® XP and 64-bit Windows Vista®.

Note 4) For Windows® XP, please use it by the administrator authority (When installing and using it.).

Note 5) In PC that uses the program to correct the problem of HotfixQ328310, it is likely to fail in the installation. In that case, please use the program to correct the problem of HotfixQ329623.

Note 6) Order USB cable separately.

Battery (LECYM/LECYU common)

LEC-JZ-CVBAT

* JZSP-BA01 manufactured by YASKAWA CONTROLS CO., LTD.

Battery for replacement.

Absolute position data is maintained by installing the battery to the battery case of the encoder cable.

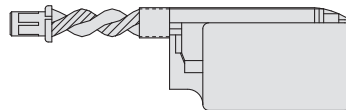

USB cable (2.5 m)

LEC-JZ-CVUSB

* JZSP-CVS06-02-E manufactured by YASKAWA CONTROLS CO., LTD.

Cable for connecting PC and driver when using the setup software (SigmaWin+™).

Do not use any cable other than this cable.

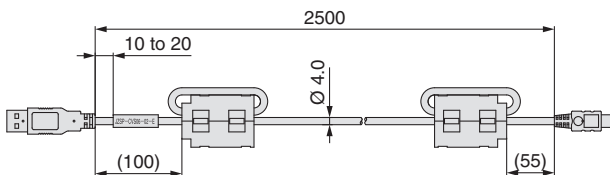

Cable for safety function device (3 m)

LEC-JZ-CVSAF

* JZSP-CVH03-03-E manufactured by YASKAWA CONTROLS CO., LTD.

Cable for connecting the driver and device when using the safety function.

Do not use any cable other than this cable.

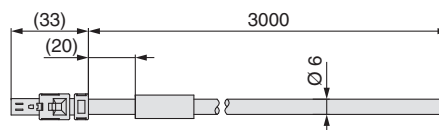

Model Selection

LECY

LEYG

LECA6
LECP6

LEC-G

LECP1

LECPA

JXC□1

JXC7□/□3/□2/□8

LECY

LEYG

LECS□

LECS-T

LECY□

Specific Product Precautions



Series **LECYM/LECYU** AC Servo Motor Driver/ Specific Product Precautions 1

Be sure to read this before handling. For Safety Instructions and Electric Actuator Precautions, refer to “Handling Precautions for SMC Products” and the Operation Manual on SMC website, <http://www.smc.eu>

Design/Selection

Warning

1. Use the specified voltage.

If the applied voltage is higher than the specified voltage, malfunction and damage to the driver may result. If the applied voltage is lower than the specified voltage, there is a possibility that the load cannot be moved due to internal voltage drop. Check the operating voltage prior to start. Also, confirm that the operating voltage does not drop below the specified voltage during operation.

2. Do not use the products outside the specifications.

Otherwise, fire, malfunction or damage to the driver/actuator can result. Check the specifications before use.

3. Install an emergency stop circuit.

Install an emergency stop outside the enclosure in easy reach to the operator so that the operator can stop the system operation immediately and intercept the power supply.

4. To prevent danger and damage due to a breakdown or malfunction of these products, which may occur at a certain probability, a backup system should be arranged in advance by using a multiple-layered structure or by making a fail-safe equipment design etc.

5. If there is a risk of fire or personal injury due to abnormal heat generation, sparking, smoke generated by the product, etc., cut off the power supply from this product and the system immediately.

Handling

Warning

1. Never touch the inside of the driver and its peripheral devices.

Otherwise, electric shock or failure can result.

2. Do not operate or set up this equipment with wet hands.

Otherwise, electric shock can result.

3. Do not use a product that is damaged or missing any components.

Electric shock, fire or injury can result.

4. Use only the specified combination between the electric actuator and driver.

Otherwise, it may cause damage to the driver or to the other equipment.

5. Be careful not to touch, get caught or hit by the workpiece while the actuator is moving.

An injury can result.

6. Do not connect the power supply or power up the product until it is confirmed that the workpiece can be moved safely within the area that can be reached by the workpiece.

Otherwise, the movement of the workpiece may cause an accident.

7. Do not touch the product when it is energised and for some time after the power has been disconnected, as it is very hot.

Otherwise, it may cause burns due to the high temperature.

8. Check the voltage using a tester at least 5 minutes after power-off when performing installation, wiring and maintenance.

Otherwise, electric shock, fire or injury can result.

Handling

Warning

9. Static electricity may cause a malfunction or damage the driver. Do not touch the driver while power is supplied to it.

Take sufficient safety measures to eliminate static electricity when it is necessary to touch the driver for maintenance.

10. Do not use the products in an area where they could be exposed to dust, metallic powder, machining chips or splashes of water, oil or chemicals.

Otherwise, a failure or malfunction can result.

11. Do not use the products in a magnetic field.

Otherwise, a malfunction or failure can result.

12. Do not use the products in an environment where flammable, explosive or corrosive gases, liquids or other substances are present.

Otherwise, fire, explosion or corrosion can result.

13. Avoid heat radiation from strong heat sources, such as direct sunlight or a hot furnace.

Otherwise, it will cause a failure to the driver or its peripheral devices.

14. Do not use the products in an environment with cyclic temperature changes.

Otherwise, it will cause a failure to the driver or its peripheral devices.

15. Do not use the products in an environment where surges are generated.

Devices (solenoid type lifters, high frequency induction furnaces, motors, etc.) that generate a large amount of surge around the product may lead to deterioration or damage to the internal circuits of the products. Avoid supplies of surge generation and crossed lines.

16. Do not install these products in a place subject to vibration and impact.

Otherwise, a malfunction or failure can result.

17. When a surge generating load such as a relay or solenoid valve is directly driven, use a product that incorporates a surge absorption element.

Mounting

Warning

1. Install the driver and its peripheral devices on fireproof material.

Direct installation on or near flammable material may cause fire.

2. Do not install these products in a place subject to vibration and impact.

Otherwise, a malfunction or failure can result.

3. The driver should be mounted on a vertical wall in a vertical direction. Also, do not cover the driver's suction/exhaust ports.

4. Install the driver and its peripheral devices on a flat surface.

If the mounting surface is not flat or uneven, excessive force may be applied to the housing and other parts resulting in a malfunction.



Series **LECYM/LECYU** AC Servo Motor Driver/ Specific Product Precautions 2

Be sure to read this before handling. For Safety Instructions and Electric Actuator Precautions, refer to “Handling Precautions for SMC Products” and the Operation Manual on SMC website, <http://www.smc.eu>

Power Supply

⚠ Caution

1. Use a power supply with low noise between lines and between power and ground.
In cases where noise is high, use an isolation transformer.
2. Take appropriate measures to prevent surges from lightning. Ground the surge absorber for lightning separately from the grounding of the driver and its peripheral devices.

Wiring

⚠ Warning

1. The driver will be damaged if a commercial power supply (100V/200V) is added to the driver's servo motor power (U, V, W). Be sure to check wiring such as wiring mistakes when the power supply is turned on.
2. Connect the ends of the U, V, W wires from the motor cable correctly to the phases (U, V, W) of the servo motor power. If these wires do not match up, it is unable to control the servo motor.

Grounding

⚠ Warning

1. For grounding actuator, connect the copper wire of the actuator to the driver's protective earth (PE) terminal and connect the copper wire of the driver to the earth via the control panel's protective earth (PE) terminal. Do not connect them directly to the control panel's protective earth (PE) terminal.

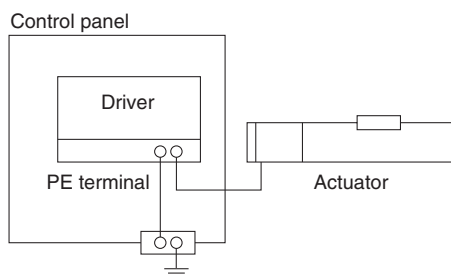

2. In the unlikely event that malfunction is caused by the ground, it may be disconnected.

Maintenance

⚠ Warning

1. Perform maintenance checks periodically.
Confirm wiring and screws are not loose.
Loose screws or wires may cause unexpected malfunction.
2. Conduct an appropriate functional inspection and test after completed maintenance.
In case of any abnormalities (if the actuator does not move or the equipment does not operate properly etc.), stop the operation of the system.
Otherwise, unexpected malfunction may occur and safety cannot be assured.
Conduct a test of the emergency stop to confirm the safety of the equipment.
3. Do not disassemble, modify or repair the driver or its peripheral devices.
4. Do not put anything conductive or flammable inside the driver.
Otherwise, fire can result.
5. Do not conduct an insulation resistance test or insulation withstand voltage test.
6. Reserve sufficient space for maintenance.
Design the system so that it allows required space for maintenance.

Model Selection

Servo Motor (24 VDC)/Step Motor (Servo/24 VDC)
LEY
LEYG

LECA6
LECP6

LEC-G

LECP1

LECPA

JXC□1

JXC7□/□3/□2/□3

LEY

LEYG

LECS□

LECS-T



LECY□

LECY

Specific Product Precautions

Safety Instructions

These safety instructions are intended to prevent hazardous situations and/or equipment damage. These instructions indicate the level of potential hazard with the labels of “Caution,” “Warning” or “Danger.” They are all important notes for safety and must be followed in addition to International Standards (ISO/IEC)*1), and other safety regulations.

-  **Caution:** Caution indicates a hazard with a low level of risk which, if not avoided, could result in minor or moderate injury.
-  **Warning:** Warning indicates a hazard with a medium level of risk which, if not avoided, could result in death or serious injury.
-  **Danger:** Danger indicates a hazard with a high level of risk which, if not avoided, will result in death or serious injury.

*1) ISO 4414: Pneumatic fluid power – General rules relating to systems.
ISO 4413: Hydraulic fluid power – General rules relating to systems.
IEC 60204-1: Safety of machinery – Electrical equipment of machines.
(Part 1: General requirements)
ISO 10218-1: Manipulating industrial robots - Safety.
etc.

Warning

1. The compatibility of the product is the responsibility of the person who designs the equipment or decides its specifications.

Since the product specified here is used under various operating conditions, its compatibility with specific equipment must be decided by the person who designs the equipment or decides its specifications based on necessary analysis and test results. The expected performance and safety assurance of the equipment will be the responsibility of the person who has determined its compatibility with the product. This person should also continuously review all specifications of the product referring to its latest catalogue information, with a view to giving due consideration to any possibility of equipment failure when configuring the equipment.

2. Only personnel with appropriate training should operate machinery and equipment.

The product specified here may become unsafe if handled incorrectly. The assembly, operation and maintenance of machines or equipment including our products must be performed by an operator who is appropriately trained and experienced.

3. Do not service or attempt to remove product and machinery/equipment until safety is confirmed.

1. The inspection and maintenance of machinery/equipment should only be performed after measures to prevent falling or runaway of the driven objects have been confirmed.
2. When the product is to be removed, confirm that the safety measures as mentioned above are implemented and the power from any appropriate source is cut, and read and understand the specific product precautions of all relevant products carefully.
3. Before machinery/equipment is restarted, take measures to prevent unexpected operation and malfunction.

4. Contact SMC beforehand and take special consideration of safety measures if the product is to be used in any of the following conditions.

1. Conditions and environments outside of the given specifications, or use outdoors or in a place exposed to direct sunlight.
2. Installation on equipment in conjunction with atomic energy, railways, air navigation, space, shipping, vehicles, military, medical treatment, combustion and recreation, or equipment in contact with food and beverages, emergency stop circuits, clutch and brake circuits in press applications, safety equipment or other applications unsuitable for the standard specifications described in the product catalogue.
3. An application which could have negative effects on people, property, or animals requiring special safety analysis.
4. Use in an interlock circuit, which requires the provision of double interlock for possible failure by using a mechanical protective function, and periodical checks to confirm proper operation.

Limited warranty and Disclaimer/ Compliance Requirements

The product used is subject to the following “Limited warranty and Disclaimer” and “Compliance Requirements”.
Read and accept them before using the product.

Limited warranty and Disclaimer

1. The warranty period of the product is 1 year in service or 1.5 years after the product is delivered, whichever is first.*2) Also, the product may have specified durability, running distance or replacement parts. Please consult your nearest sales branch.
2. For any failure or damage reported within the warranty period which is clearly our responsibility, a replacement product or necessary parts will be provided. This limited warranty applies only to our product independently, and not to any other damage incurred due to the failure of the product.
3. Prior to using SMC products, please read and understand the warranty terms and disclaimers noted in the specified catalogue for the particular products.

*2) Vacuum pads are excluded from this 1 year warranty.

A vacuum pad is a consumable part, so it is warranted for a year after it is delivered. Also, even within the warranty period, the wear of a product due to the use of the vacuum pad or failure due to the deterioration of rubber material are not covered by the limited warranty.

Compliance Requirements

1. The use of SMC products with production equipment for the manufacture of weapons of mass destruction (WMD) or any other weapon is strictly prohibited.
2. The exports of SMC products or technology from one country to another are governed by the relevant security laws and regulations of the countries involved in the transaction. Prior to the shipment of a SMC product to another country, assure that all local rules governing that export are known and followed.

Caution

1. The product is provided for use in manufacturing industries.

The product herein described is basically provided for peaceful use in manufacturing industries.
If considering using the product in other industries, consult SMC beforehand and exchange specifications or a contract if necessary.
If anything is unclear, contact your nearest sales branch.

Caution

SMC products are not intended for use as instruments for legal metrology.

Measurement instruments that SMC manufactures or sells have not been qualified by type approval tests relevant to the metrology (measurement) laws of each country. Therefore, SMC products cannot be used for business or certification ordained by the metrology (measurement) laws of each country.

Safety Instructions

Be sure to read “Handling Precautions for SMC Products” (M-E03-3) before using.

SMC Corporation (Europe)

Austria	☎ +43 (0)2262622800	www.smc.at	office@smc.at
Belgium	☎ +32 (0)33551464	www.smc.be	info@smc.be
Bulgaria	☎ +359 (0)2807670	www.smc.bg	office@smc.bg
Croatia	☎ +385 (0)13707288	www.smc.hr	office@smc.hr
Czech Republic	☎ +420 541424611	www.smc.cz	office@smc.cz
Denmark	☎ +45 70252900	www.smc.dk.com	smc@smc.dk.com
Estonia	☎ +372 6510370	www.smc.pneumatics.ee	smc@smc.pneumatics.ee
Finland	☎ +358 207513513	www.smc.fi	smc.fi@smc.fi
France	☎ +33 (0)164761000	www.smc-france.fr	info@smc-france.fr
Germany	☎ +49 (0)61034020	www.smc.de	info@smc.de
Greece	☎ +30 210 2717265	www.smc.hellas.gr	sales@smc.hellas.gr
Hungary	☎ +36 23513000	www.smc.hu	office@smc.hu
Ireland	☎ +353 (0)14039000	www.smc.pneumatics.ie	sales@smc.pneumatics.ie
Italy	☎ +39 0292711	www.smcitalia.it	mailbox@smcitalia.it
Latvia	☎ +371 67817700	www.smc.lv	info@smc.lv

Lithuania	☎ +370 5 2308118	www.smc.lt	info@smc.lt
Netherlands	☎ +31 (0)205318888	www.smc.nl	info@smc.nl
Norway	☎ +47 67129020	www.smc-norge.no	post@smc-norge.no
Poland	☎ +48 222119600	www.smc.pl	office@smc.pl
Portugal	☎ +351 226166570	www.smc.eu	postpt@smc.smces.es
Romania	☎ +40 213205111	www.smcromania.ro	smcromania@smcromania.ro
Russia	☎ +7 8127185445	www.smc-pneumatik.ru	info@smc-pneumatik.ru
Slovakia	☎ +421 (0)413213212	www.smc.sk	office@smc.sk
Slovenia	☎ +386 (0)73885412	www.smc.si	office@smc.si
Spain	☎ +34 945184100	www.smc.eu	post@smc.smces.es
Sweden	☎ +46 (0)86031200	www.smc.nu	post@smc.nu
Switzerland	☎ +41 (0)523963131	www.smc.ch	info@smc.ch
Turkey	☎ +90 212 489 0 440	www.smc.pneumatik.com.tr	info@smc.pneumatik.com.tr
UK	☎ +44 (0)845 121 5122	www.smc.uk	sales@smc.uk

SMC CORPORATION Akihabara UDX 15F, 4-14-1, Sotokanda, Chiyoda-ku, Tokyo 101-0021, JAPAN Phone: 03-5207-8249 FAX: 03-5298-5362