

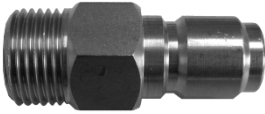

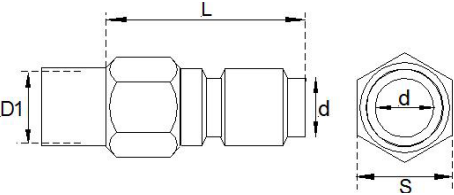



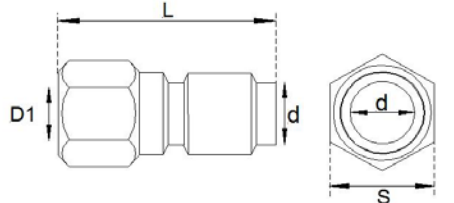

Adaptateurs en inox

 ADAPT3/8-M ADAPT1/2-M		ADAPT3/8-M: Adaptateur 3/8" mal. ADAPT1/2-M: Adaptateur 1/2" mal.				
		Product code	L	d	D1	S
		ADAPT3/8-M	51,1	10,4	3/8"	22
ADAPT1/2-M	53,8	11,8	1/2"	22		
 ADAPT1/2-F ADAPT1/4-F		ADAPT1/2-F: Adaptateur 1/2" femelle. ADAPT1/4-F: Adaptateur 1/4" femelle.				
		Product code	L	d	D1	S
		ADAPT1/2-F	49,3	11,8	1/2"	27
ADAPT1/4-F	40,3	11,8	1/4"	22		
 ADAPW-11,5		ADAPW-11,5: Adaptateur, pour souder.				
		Product code	L	d	D1	S
		ADAPW-11,5	30	11,5	11,5	nvt
 ADAPN3/8-F ADAPN1/2-F		ADAPN3/8-F: Adaptateur 3/8" femelle ADAPN1/2-F: Adaptateur 1/2" femelle				
		Product code	L	d	D1	S
		ADAPN3/8-F	42	11,5	3/8"	19
ADAPN1/2-F	42	11,5	1/2"	22		
 ADAPN1/4-F ADAPN1/4-F-S		ADAPN1/4-F-S: Adaptateur 1/4" femelle (<i>short version</i>) ADAPN1/4-F: Adaptateur 1/4" femelle				
		Product code	L	d	D1	S
		ADAPN1/4-F	55,2	11,5	1/4"	17
ADAPN1/4-F-S	40,5	11,5	1/4"	17		
 ADAPH13 ADAPH16 ADAPH19		ADAPH13: Adaptateur avec embout de 13mm. ADAPH16: Adaptateur avec embout de 16mm. ADAPH19: Adaptateur avec embout de 19mm.				
		Product code	L	d	D1	
		ADAPH13	57,5	10,0	12,8 – 13,3	
ADAPH16	64,0	10,0	15,8 – 16,8			
ADAPH19	65,2	10,0	19,1 – 19,9			

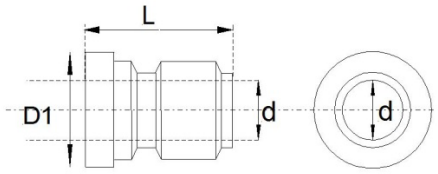
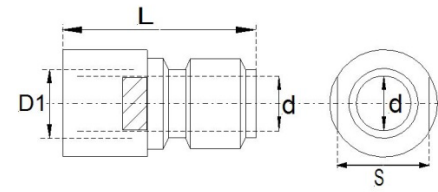
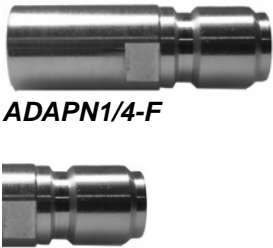
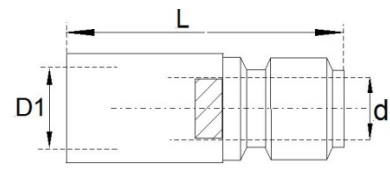
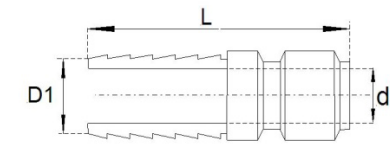