







- Toutes les fixations peuvent être utilisées en atmosphères explosibles, zones 1-21 et 2-22

## SELECTION DU MATERIEL <sup>(1)</sup>

								
				Pattes d'équerre sur extrémité (lot de 2 pièces) <b>MS1</b>	Patte d'équerre haute <b>MS3</b>	Bride avant ou arrière rectangulaire <b>MF1 - MF2</b>		
Ø (mm)				tôle d'acier	acier inox	alliage léger	acier	acier inox
449	453	454	450					
20	-	-	-	P493AL124000A00	-	-	P493AL126000A00	-
25	-	-	-	P493AM124000A00	-	-	P493AM126000A00	-
32	32	32	32	P493A3124000A00	P493A3124200A00	P493A3125100A00	P493A3126000A00	P493A3126200A00
40	40	40	40	P493A4124000A00	P493A4124200A00	P493A4125100A00	P493A4126000A00	P493A4126200A00
50	50	50	50	P493A5124000A00	P493A5124200A00	P493A5125100A00	P493A5126000A00	P493A5126200A00
63	63	63	63	P493A6124000A00	P493A6124200A00	P493A6125100A00	P493A6126000A00	P493A6126200A00
80	80	80	80	P493A8124000A00	P493A8124200A00	P493A8125100A00	P493A8126000A00	P493A8126200A00
100	100	100	100	P493A1124000A00	P493A1124200A00	-	P493A1126000A00	P493A1126200A00
-	-	-	125	P493AP124000A00	-	-	P493AP126000A00	-
-	-	-	160	P493AQ124000A00	-	-	P493AQ126000A00	-
-	-	-	200	P493AR124000A00	-	-	P493AR126000A00	-

								
				Tourillon mâle <b>MT4</b>	Tourillon mâle <b>MT4</b>	Support tourillon mâle (lot de 2 pièces) <b>AT4</b>		
				livré seul	monté libre	livré seul	livré fixé /XV <sup>(2)</sup>	
Ø (mm)				fonte		fonte		aluminium
449	453				450			
20	-	-	-	-	-	-	-	-
25	-	-	-	-	-	-	-	-
32	32	P493B3111000A00	Voir page : P226-2 et P229-3		32	P493A3113000A00	<a href="#">Consulter pour les codes notre configurateur (Dynamic Product Modeling) sur : <a href="http://www.asco.com">www.asco.com</a></a>	P493A3112100A00
40	40	P493A4111000A00			40	P493A4113000A00		P493A4112100A00
50	50	P493A5111000A00			50	P493A5113000A00		P493A5112100A00
63	63	P493A6111000A00			63	P493A6113000A00		P493A6112100A00
80	80	P493A8111000A00			80	P493A8113000A00		P493A6112100A00
100	100	P493A11111000A00			100	P493A1113000A00		P493A1112100A00
-	-	-	-	125	P493AP113000A00	P493A1112100A00		
-	-	-	-	160	P493AQ113000A00	P493AQ112100A00		
-	-	-	-	200	P493AR113000A00	P493AQ112100A00		

<sup>(1)</sup> Voir encombrements page suivante.

NOTE : A l'exception du tourillon mâle, les fixations sont livrées non montées

<sup>(2)</sup> Tourillon livré fixé sur le tube: spécifier la cote XV à la commande.

**FIXATIONS DE FOND <sup>(1)</sup>**

Ø (mm)				Chape arrière démontable <b>MP2</b>			
449	453	454	450	alliage léger	fonte	alliage léger anti-corrosion (traitement NPC)	acier inox
20	-	-	-	-	-	-	-
25	-	-	-	-	-	-	-
32	32	32	32	P493A3121110A00	-	P493A3121100NPC	P493A3121200A00
40	40	40	40	P493A4121110A00	-	P493A4121100NPC	P493A4121200A00
50	50	50	50	P493A5121110A00	-	P493A5121100NPC	P493A5121200A00
63	63	63	63	P493A6121110A00	-	P493A6121100NPC	P493A6121200A00
80	80	80	80	P493A8121110A00	-	P493A8121100NPC	P493A8121200A00
100	100	100	100	P493A1121110A00	-	P493A1121100NPC	P493A1121200A00
-	-	-	125	-	P493AP121010A00	-	-
-	-	-	160	-	P493AQ121010A00	-	-
-	-	-	200	-	P493AR121010A00	-	-



Ø (mm)				Tenon arrière démontable <b>MP4</b>			
449	453	454	450	alliage léger	fonte	alliage léger anti-corrosion (traitement NPC)	acier inox
20	-	-	-	P493AL122110A00	-	-	-
25	-	-	-	P493AM122110A00	-	-	-
32	32	32	32	P493A3122100A00	-	P493A3122100NPC	P493A3122200A00
40	40	40	40	P493A4122100A00	-	P493A4122100NPC	P493A4122200A00
50	50	50	50	P493A5122100A00	-	P493A5122100NPC	P493A5122200A00
63	63	63	63	P493A6122100A00	-	P493A6122100NPC	P493A6122200A00
80	80	80	80	P493A8122100A00	-	P493A8122100NPC	P493A8122200A00
100	100	100	100	P493A1122100A00	-	P493A1122100NPC	P493A1122200A00
-	-	-	125	-	P493AP122010A00	-	-
-	-	-	160	-	P493AQ122010A00	-	-
-	-	-	200	-	P493AR122010A00	-	-





Ø (mm)				Tenon arrière démontable <b>AB7</b>				Chape arrière pour tenon rotulé <b>AB6</b>	Tenon arrière droit rotulé <sup>(2)</sup> <b>MP6</b>	Tenon arrière d'équerre rotulé <sup>(2)</sup> <b>AB5</b>
449	453	454	450	alliage léger	fonte	alliage léger anti-corrosion (traitement NPC)	acier inox	acier	acier	acier
20	-	-	-	-	-	-	-	-	-	-
25	-	-	-	-	-	-	-	-	-	-
32	32	32	32	P493A3123110A00	-	P493A3123100NPC	P493A3123200A00	P493A3129000A00	P493A3128000A00	P493A3127000A00
40	40	40	40	P493A4123110A00	-	P493A4123100NPC	P493A4123200A00	P493A4129000A00	P493A4128000A00	P493A4127000A00
50	50	50	50	P493A5123110A00	-	P493A5123100NPC	P493A5123200A00	P493A5129000A00	P493A5128000A00	P493A5127000A00
63	63	63	63	P493A6123110A00	-	P493A6123100NPC	P493A6123200A00	P493A6129000A00	P493A6128000A00	P493A6127000A00
80	80	80	80	P493A8123110A00	-	P493A8123100NPC	P493A8123200A00	P493A8129000A00	P493A8128000A00	P493A8127000A00
100	100	100	100	P493A1123110A00	-	P493A1123100NPC	P493A1123200A00	P493A1129000A00	P493A1128000A00	P493A1127000A00
-	-	-	125	-	P493AP123010A00	-	-	P493AP129000A00	P493AP128000A00	P493AP127000A00
-	-	-	160	-	P493AQ123010A00	-	-	-	-	-
-	-	-	200	-	P493AR123010A00	-	-	-	-	-

<sup>(1)</sup> Voir encombrements page suivante.

<sup>(2)</sup> Ces accessoires permettent une compensation angulaire sphérique de 4°.

FIXATIONS DE TIGE <sup>(1)</sup>

								
				Chape femelle d'extrémité de tige <sup>(2)</sup> <b>AP2</b>	Tenon à rotule pour extrémité de tige <b>AP6</b>		Compensateur d'alignement <sup>(3)</sup>	
Ø (mm)				acier	acier inox	acier	acier inox	acier
449	453	454	450					
20-25	-	-	-	P493AL431000A00	-	P493AL432000A00	-	-
32-40	32	32	32	P493A3131000A00	P493A3131200A00	P493A3132000A00	P493A3132200A00	P493A3134000A00
50-63	40	40	40	P493A4131000A00	P493A4131200A00	P493A4132000A00	P493A4132200A00	P493A4134000A00
80-100	50-63	50-63	50-63	P493A5131000A00	P493A5131200A00	P493A5132000A00	P493A5132200A00	P493A5134000A00
-	80-100	80-100	80-100	P493A8131000A00	P493A8131200A00	P493A8132000A00	P493A8132200A00	P493A8134000A00
-	-	-	125	P493AP131000A00	-	P493AP132000A00	-	P493AP134000A00
-	-	-	160-200	P493AQ131000A00	-	P493AQ132000A00	-	-

<sup>(1)</sup> Voir encombrements page suivante.

<sup>(2)</sup> Ø125 à 200 mm: Chapes avec verrouillage de l'axe par goupille

<sup>(3)</sup> Cet accessoire permet des compensations angulaire sphérique de 4° et radiale de 0,7 mm

**ENCOMBREMENTS (mm), MASSES (kg)**

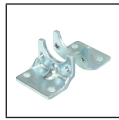

**FIXATION**  
Pattes d'équerre sur extrémité  
**MS1**

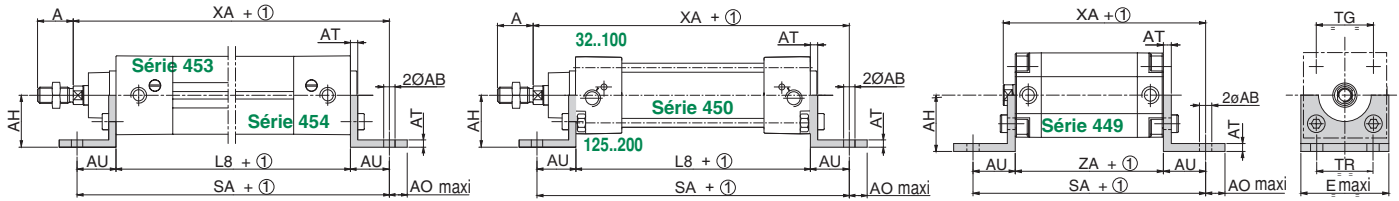

① Course



**FIXATION**  
Patte d'équerre haute  
**MS3**

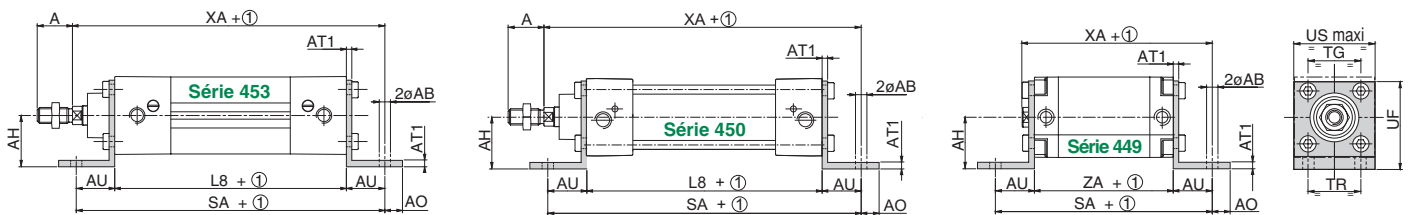

① Course

Ø (mm)				ØAB	A	AO	AH	AT	AT1	AU	E	L8	SA		TR	TG	UF	US	XA		ZA	masse	
449	453	454	450										449	453/454/450					449	453/454/450		2 x MS1	1 x MS3
20	-	-	-	7	-	7	27	4	-	16	38	-	69	-	22	22	-	-	59	-	37	0,064	-
25	-	-	-	7	-	7	29	4	-	16	41	-	71	-	26	26	-	-	61	-	39	0,076	-
32	32	32	32	7	22	11	32	4	8	24	50	94	92	142	32	32,5	54	50	79	144	44	0,150	0,180
40	40	40	40	9	24	13	36	4	8	28	58	105	101	161	36	38	62	58	83	163	45	0,190	0,250
50	50	50	50	9	32	13	45	5	10	32	70	106	109	170	45	46,5	77	70	88	175	45	0,395	0,470
63	63	63	63	9	32	13	50	5	10	32	85	121	113	185	50	56,5	87	85	91,5	190	49	0,445	0,595
80	80	80	80	12	40	20	63	6	12	41	105	128	146	210	63	72	110	105	107,5	215	54	0,790	1,265
100	100	100	100	14,5	40	25	71	6	12	41	130	138	149	220	75	89	130	130	128,5	230	67	1,400	-
-	-	-	125	16,5	54	25	90	8	16	45	157	160	-	250	90	110	161	157	-	270	-	2,330	-
-	-	-	160	18,5	72	25	115	10	-	60	195	180	-	300	115	140	-	-	-	320	-	4,860	-
-	-	-	200	24	72	35	135	12	-	70	238	180	-	320	135	175	-	-	-	345	-	7,900	-



**FIXATION**  
Bride avant ou arrière  
**MF1 - MF2**  
Rectangulaire

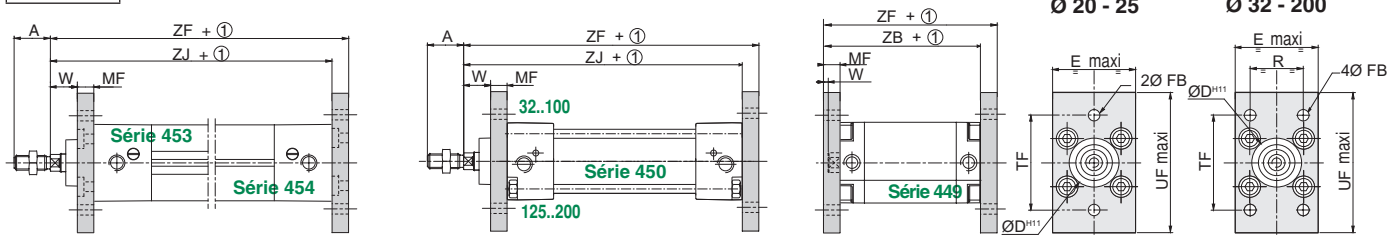

① Course

Ø (mm)				A	ØD	E	ØFB	MF	R	TF	UF	W		ZB	ZJ	ZF		masse
449	453	454	450									449	453/454/450			449	453/454/450	
20	-	-	-	-	16	38	6,6	8	-	55	70	2	-	43	-	51	-	0,016
25	-	-	-	-	16	41	6,6	8	-	60	76	2	-	45	-	53	-	0,020
32	32	32	32	22	30	50	7	10	32	64	86	3	16	55	120	65	130	0,190
40	40	40	40	24	35	58	9	10	36	72	96	3	20	55	135	65	145	0,245
50	50	50	50	32	40	70	9	12	45	90	115	4	25	56	143	67	155	0,500
63	63	63	63	32	45	85	9	12	50	100	130	4	25	59,5	158	71,5	170	0,580
80	80	80	80	40	45	105	12	16	63	126	165	6	30	66,5	174	82,5	190	1,390
100	100	100	100	40	55	130	14	16	75	150	187	6	35	77,5	189	93,5	205	1,630
-	-	-	125	54	60	157	16	20	90	180	224	-	45	-	225	-	245	4,270
-	-	-	160	72	65	195	18	20	115	230	280	-	60	-	260	-	280	6,880
-	-	-	200	72	75	238	22	25	135	270	320	-	70	-	275	-	300	12,330

Consulter notre documentation sur : [www.asco.com](http://www.asco.com)

**ENCOMBREMENTS (mm), MASSES (kg)**



**FIXATION**

Tourillon mâle

**MT4**

(Séries 449-453)

Cote XV à préciser à la commande.

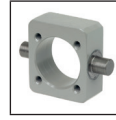

**FIXATION**

Tourillon mâle

**MT4**

(Série 450)

Cote XV à préciser à la commande.

Série 453

Série 449

Série 450

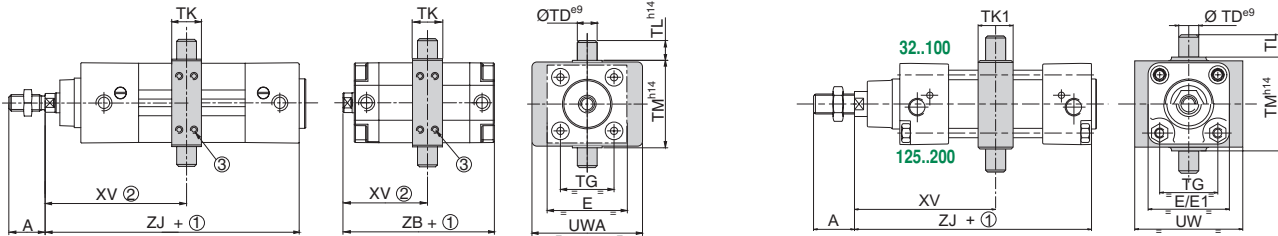

Ø (mm)				A	E	E1 <sup>(1)</sup>	TD	TG	TK	TK1	TL	TM	UW	UWA	ZB	ZJ	XV mini			XV maxi (+ course)			course mini.	masse	
	449	453	450														449	453	450	449	453	450		449	449/453
32	32	32	22	46,5	48	12	32,5	20	22	12	50 <sup>(2)</sup>	55	65	55	120	32	71	72	26	76	75	5	0,185	0,2	
40	40	40	24	52	54	16	38	20	28	16	63	58	75	55	135	32	79	83	27	86	82	5	0,33	0,4	
50	50	50	32	64	66	16	46,5	20	28	16	75	68	90	56	143	33	86	90	28	95	91	5	0,475	0,5	
63	63	63	32	74	78	20	56,6	25	35	20	90	84	100	59,5	158	35	89	94	30	107	102	5	0,57	0,9	
80	80	80	40	92	96	20	72	25	35	20	110	102	130	66,5	174	40	102	107	35	119	114	5	1,12	1,1	
100	100	100	40	109	115	25	89	30	40	25	132	145	140	87,5	189	45	109	114	42	132	127	5	1,52	1,86	
-	-	125	54	145	-	25	110	40	40	25	160	175	175	-	225	-	-	135	-	156	-	-	-	2,55	
-	-	160	72	180	-	32	140	50	50	32	200	220	220	-	260	-	-	160	-	181	-	-	-	4,7	
-	-	200	72	220	-	32	175	50	50	32	250	260	260	-	275	-	-	174	-	197	-	-	-	4,2	

<sup>(1)</sup> Appliquée sur la série 450 pour les options AT1, AT2, HTP, FPM, FFP et NPC.

<sup>(2)</sup> L'encombrement TM est de 53 pour les séries 449 et 453 pour le diamètre 32. Selon la norme ISO 15552, l'encombrement TM est de 50 mm, tolérance h14.

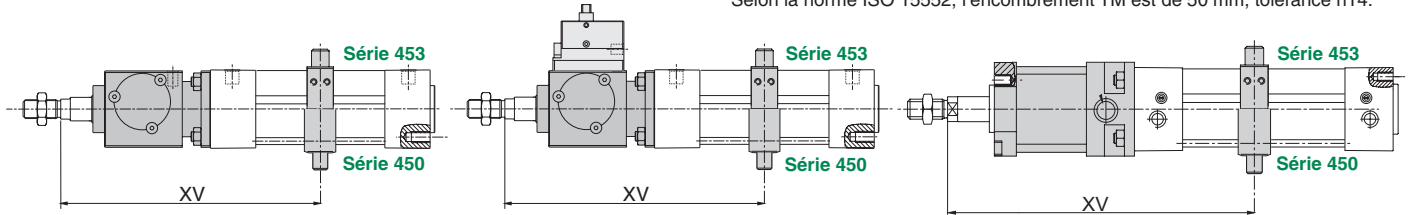

Ø (mm)	DISPOSITIF DE BLOCAGE STATIQUE				DISPOSITIF DE BLOCAGE DYNAMIQUE				
	XV mini		XV maxi (+ course)		XV mini		XV maxi (+ course)		
453	450	453	450	453	450	453	450	453	450
32	32	131	132	136	135	-	-	-	-
40	40	149	153	156	152	174	178	181	177
50	50	176	180	185	181	198	202	207	203
63	63	179	184	197	192	209	214	227	222
80	80	212	217	229	224	242	247	259	254
100	100	219	224	242	237	259	264	282	277

- ① Course
- ② Sauf si la cote XV est définie à la commande, la position du tourillon est réglable le long du tube. En conséquence, le tourillon est livré non bloqué sur le tube et le serrage est à effectuer sur site.
- ③ 8 vis de serrage



**FIXATION**

Support tourillon mâle (lot de 2 pièces)

**AT4**

(Séries 449-453-450)

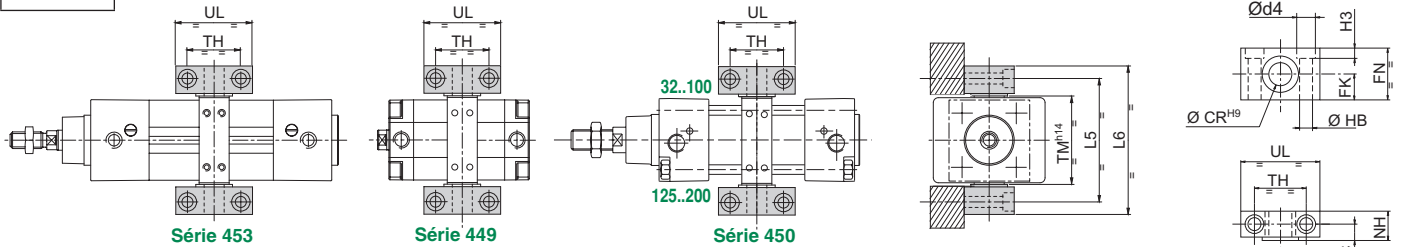

Ø (mm)				C	ØCR	Ød4	FK	FN	HB	H3	L5	L6	NH	TH	TM	UL	masse
	449	453	450														
32	32	32	10,5	12	11	15	30	6,6	6,8	74	89	18	32	50 <sup>(2)</sup>	46	0,12	
40	40	40	12	16	15	18	36	9	9	87	105	21	36	63	55	0,23	
50	50	50	12	16	15	18	36	9	9	99	117	21	36	75	55	0,23	
63	63	63	13	20	18	20	40	11	11	116	136	23	40	90	65	0,33	
80	80	80	13	20	18	20	40	11	11	136	156	23	40	110	65	0,33	
100	100	100	16	25	20	25	50	13,5	13	164	189	28,5	50	132	75	0,58	
-	-	125	16	25	20	25	50	13,5	13	192	219	28,5	50	160	75	0,58	
-	-	160	22,5	32	26	30	60	17,5	17,5	245	280	40	60	200	92	1,03	
-	-	200	22,5	32	26	30	60	17,5	17,5	295	330	40	60	250	92	1,03	

<sup>(2)</sup> L'encombrement TM est de 53 pour les séries 449 et 453 pour le diamètre 32.

ENCOMBREMENTS (mm), MASSES (kg) 



**FIXATION ARRIÈRE**  
Chape arrière démontable  
**MP2**

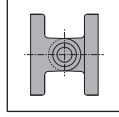
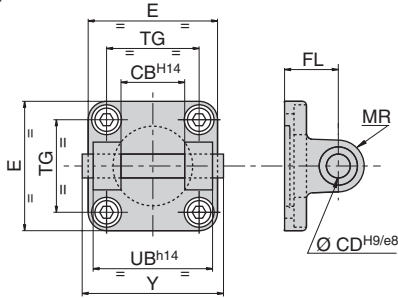

**MP2 + MP4**  
Chape arrière démontable  
+  
Tenon arrière démontable

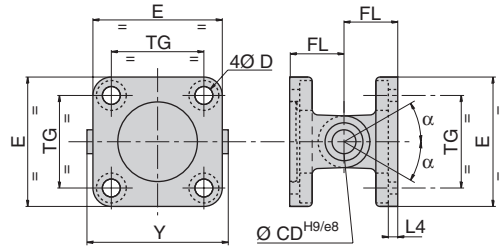

**FIXATION ARRIÈRE**  
Tenon arrière démontable  
**MP4**

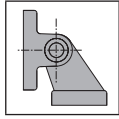
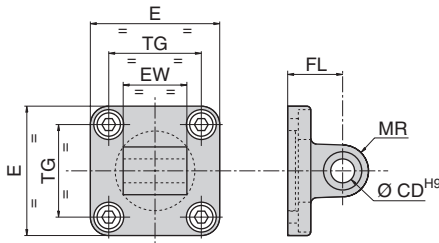

**MP2 + AB7**  
Chape arrière démontable  
+  
Tenon arrière démontable

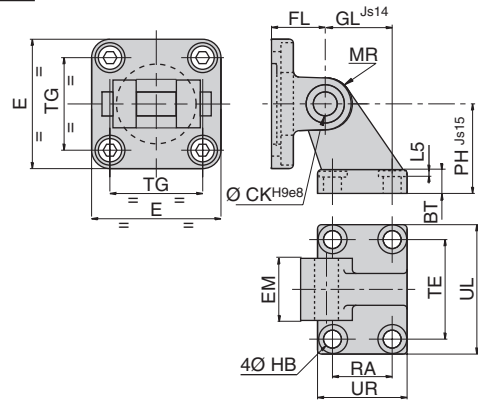

**FIXATION ARRIÈRE**  
Tenon arrière démontable  
**AB7**

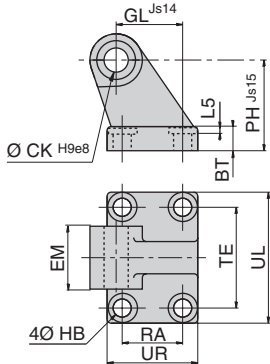

① Course

Ø (mm)	masse																							
	alliage léger			fonte			acier inox																	
	MP2	MP4	AB7	MP2	MP4	AB7	MP2	MP4	AB7	MP2	AB7													
449	453	454	450	-	-	-	-	-	-	-	-	-	-	-	-	-	-	-	-	-	-	-	-	-
20	-	-	-	-	0,085	-	-	-	-	-	-	-	-	-	-	-	-	-	-	-	-	-	-	-
25	-	-	-	-	0,092	-	-	-	-	-	-	-	-	-	-	-	-	-	-	-	-	-	-	-
32	32	32	32	0,105	0,085	0,16	-	-	-	-	-	0,41	0,41	0,16	-	-	-	-	-	-	-	-	-	-
40	40	40	40	0,15	0,092	0,23	-	-	-	-	-	0,67	0,67	0,24	-	-	-	-	-	-	-	-	-	-
50	50	50	50	0,24	0,17	0,39	-	-	-	-	-	0,97	0,97	0,42	-	-	-	-	-	-	-	-	-	-
63	63	63	63	0,37	0,25	0,57	-	-	-	-	-	1,585	1,585	0,525	-	-	-	-	-	-	-	-	-	-
80	80	80	80	0,635	0,445	0,95	-	-	-	-	-	3,46	3,46	1,055	-	-	-	-	-	-	-	-	-	-
100	100	100	100	0,99	0,755	0,5	-	-	-	-	-	5,35	5,35	1,36	-	-	-	-	-	-	-	-	-	-
-	-	-	125	-	-	-	3,57	3,1	6,61	-	-	-	-	-	-	-	-	-	-	-	-	-	-	-
-	-	-	160	-	-	-	6,66	5,22	12,47	-	-	-	-	-	-	-	-	-	-	-	-	-	-	-
-	-	-	200	-	-	-	9,89	7,78	16,76	-	-	-	-	-	-	-	-	-	-	-	-	-	-	-

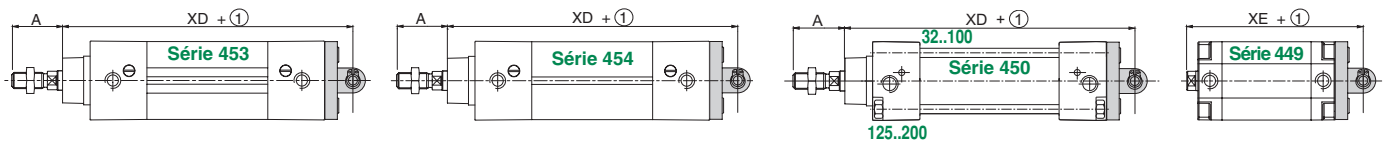

Ø (mm)	A	BT	CB EM	CD CK	D	E maxi	EW	FL	GL	HB	L4	L5	MR	PH	RA	TE	TG	UB	UR	UL	XD	XE	Y	α			
																									449	453	454
20	-	-	-	8	-	38	16	20	-	-	-	-	9	-	-	-	22	-	-	-	-	63	-	-			
25	-	-	-	8	-	41	16	20	-	-	-	-	9	-	-	-	26	-	-	-	-	65	-	-			
32	32	32	32	22	8	26	10	6,6	50	26	22	21	6,6	5,5	1,6	11	32	18	38	32,5	45	31	51	142	73	56	45°
40	40	40	40	24	10	28	12	6,6	58	28	25	24	6,6	5,5	1,6	13	36	22	41	38	52	35	54	160	77	63	50°
50	50	50	50	32	12	32	12	9	70	32	27	33	9	6,5	1,6	13	45	30	50	46,5	60	45	65	170	80	71	40°
63	63	63	63	32	12	40	16	9	85	40	32	37	9	6,5	1,6	17	50	35	52	56,5	70	50	67	190	89	81	55°
80	80	80	80	40	14	50	16	11	105	50	36	47	11	10	2,5	17	63	40	66	72	90	60	86	210	100	101	45°
100	100	100	100	40	15	60	20	11	130	60	41	55	11	10	2,5	21	71	50	76	89	110	70	96	230	118	128	35*
-	-	-	125	54	20	70	25	14	157	70	50	70	14	10	3,2	26	90	60	94	110	130	90	124	275	-	149	30°
-	-	-	160	72	25	90	30	18	195	90	55	97	18	10	4	31	115	88	118	140	170	126	156	315	-	183	30°
-	-	-	200	72	30	90	30	18	238	90	60	105	18	11	4	31	135	90	122	175	170	130	162	335	-	183	30°

**ENCOMBREMENTS (mm), MASSES (kg)**



**FIXATION ARRIERE**  
Chape arriere pour tenon rotulé  
**AB6**

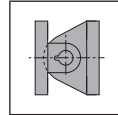
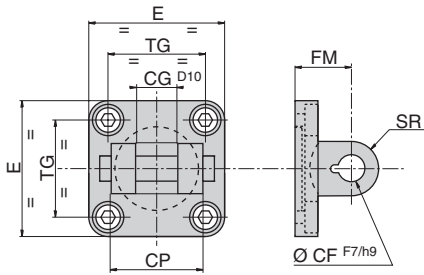

**AB6 + MP6**  
Chape arriere pour tenon rotulé  
+ Tenon arriere droit rotulé

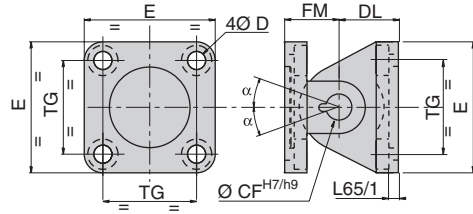

**FIXATION ARRIERE**  
Tenon arriere droit rotulé  
**MP6**

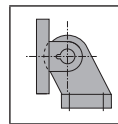
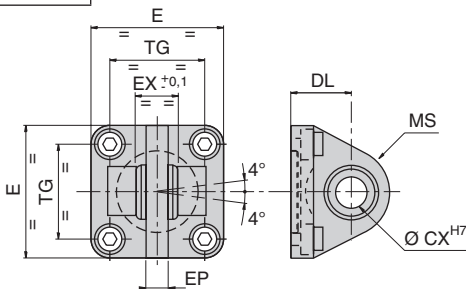

**AB6 + AB5**  
Chape arriere pour tenon rotulé  
+ Tenon arriere d'équerre rotulé

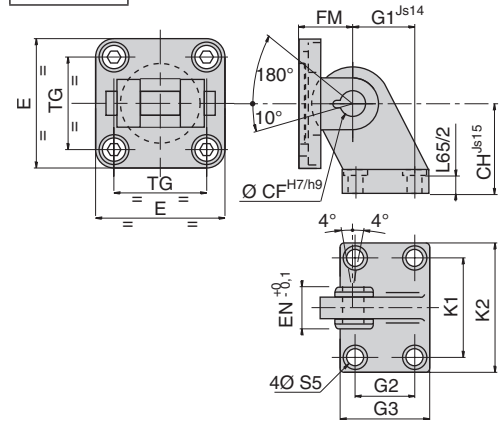

**FIXATION ARRIERE**  
Tenon arriere d'équerre rotulé  
**AB5**

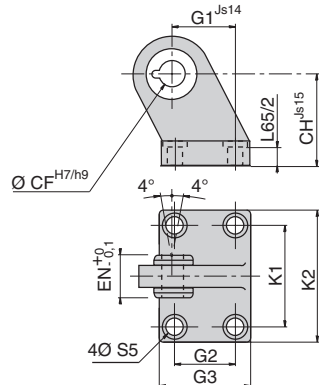

Ø (mm)				masse		
				acier		
449	453	454	450	AB6	AB5	MP6
20	-	-	-	-	-	-
25	-	-	-	-	-	-
32	32	-	32	0,190	0,180	0,180
40	40	-	40	0,300	0,230	0,290
50	50	-	50	0,460	0,450	0,420
63	63	-	63	0,680	0,520	0,650
80	80	-	80	1,460	0,940	1,210
100	100	-	100	2,130	1,070	1,870
-	-	-	125	4,240	2,470	3,640
-	-	-	160	-	-	-
-	-	-	200	-	-	-

① Course

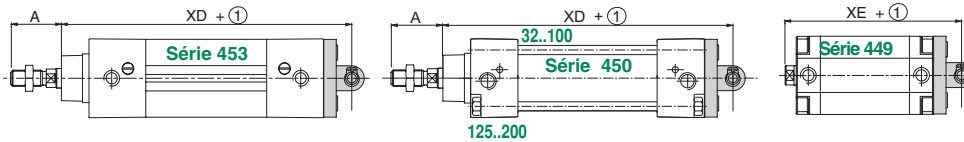

Ø (mm)				A	CG	CH	CP	CX CF	DL FM	E maxi	EN EX	EP	G1	G2	G3 maxi	K1	K2 maxi	L65/1	L65/2	MS maxi	TG	SR maxi	S5 D	XD	XE	α
449	453	454	450																							
20	-	-	-	-	-	-	-	-	-	-	-	-	-	-	-	-	-	-	-	-	-	-	-	-	-	
25	-	-	-	-	-	-	-	-	-	-	-	-	-	-	-	-	-	-	-	-	-	-	-	-	-	
32	32	-	32	22	14	32	34	10	22	50	14	10,5	21	18	31	38	51	5,5	8,5	15	32,5	11	6,6	142	73	40°
40	40	-	40	24	16	36	40	12	25	58	16	12	24	22	35	41	54	5,5	8,5	18	38	13	6,6	160	77	45°
50	50	-	50	32	21	45	45	16	27	70	21	15	33	30	45	50	65	6,5	10	20	46,5	18	9	170	80	35°
63	63	-	63	32	21	50	51	16	32	85	21	15	37	35	50	52	67	6,5	10	23	56,5	18	9	190	89	50°
80	80	-	80	40	25	63	65	20	36	105	25	18	47	40	60	66	86	10	11,5	27	72	22	11	210	100	40°
100	100	-	100	40	25	71	75	20	41	130	25	18	55	50	70	76	96	10	12,5	30	89	22	11	230	118	30°
-	-	-	125	54	37	90	97	30	50	157	37	25	70	60	90	94	124	10	16,5	40	110	30	14	275	-	25°
-	-	-	160	72	-	-	-	-	-	-	-	-	-	-	-	-	-	-	-	-	-	-	-	315	-	-
-	-	-	200	72	-	-	-	-	-	-	-	-	-	-	-	-	-	-	-	-	-	-	-	335	-	-

01434FR-2016/R01 Délais, spécifications et dimensions peuvent être modifiées sans préavis. Tous droits réservés.

**ENCOMBREMENTS (mm), MASSES (kg)**



**FIXATION DE TIGE**

Chape femelle pour extrémité de tige  
AP2



**FIXATION DE TIGE**

Tenon à rotule pour extrémité de tige  
AP6

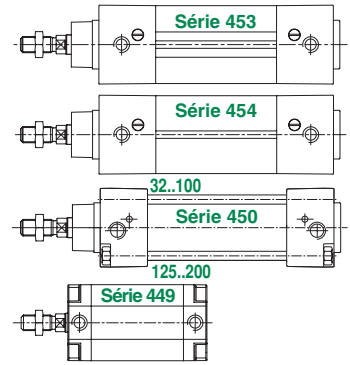
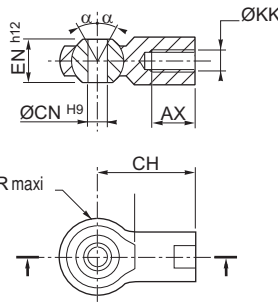
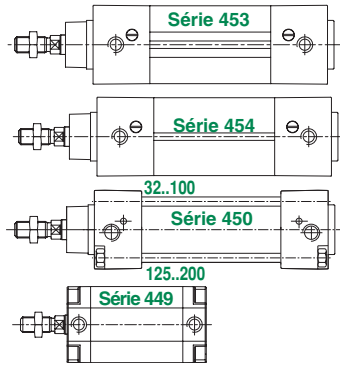
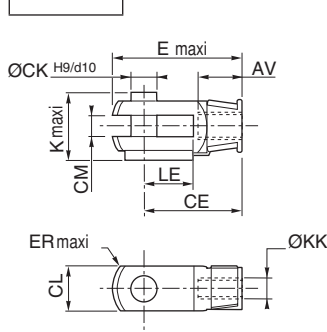

Ø (mm)	Ø				AV AX	CE	CH	ØCK	CL	CM	ØCN	E max.	EN	ER max.	K	ØKK	LE	α	masse			
	449	453	454	450															acier		acier inox	
																			AP2	AP6	AP2	AP6
20	-	-	-	-	15	32	36	8	16	8 <sup>+0,5 +0,15</sup>	8	42	12	12	22	M8x1,25	16	4°	0,08	0,04	-	-
25	-	-	-	-	15	32	36	8	16	8 <sup>+0,5 +0,15</sup>	8	42	12	12	22	M8x1,25	16	4°	0,08	0,04	-	-
32	32	32	32	32	20	40	43	10	20	10 <sup>+0,5 +0,15</sup>	10	56	14	14	26	M10x1,25	20	4°	0,1	0,07	0,09	0,08
40	-	-	-	-	20	40	43	10	20	10 <sup>+0,5 +0,15</sup>	10	56	14	14	26	M10x1,25	20	4°	0,1	0,07	-	-
-	40	40	40	40	22	48	50	12	24	12 <sup>+0,5 +0,15</sup>	12	67	16	16	32	M12x1,25	24	4°	0,15	0,12	0,16	0,12
50	-	-	-	-	22	48	50	12	24	12 <sup>+0,5 +0,15</sup>	12	67	16	16	32	M12x1,25	24	4°	0,15	0,12	-	-
-	50	50	50	50	28	64	64	16	32	16 <sup>+0,5 +0,15</sup>	16	89	21	21	41	M16x1,5	32	4°	0,33	0,22	0,31	0,23
63	-	-	-	-	22	48	50	12	24	12 <sup>+0,5 +0,15</sup>	12	67	16	16	32	M12x1,25	24	4°	0,15	0,12	-	-
-	63	63	63	63	28	64	64	16	32	16 <sup>+0,5 +0,15</sup>	16	89	21	21	41	M16x1,5	32	4°	0,33	0,22	0,31	0,23
80	-	-	-	-	28	64	64	16	32	16 <sup>+0,5 +0,15</sup>	16	89	21	21	41	M16x1,5	32	4°	0,33	0,22	-	-
-	80	80	80	80	33	80	77	20	40	20 <sup>+0,6 +0,15</sup>	20	112	25	25	48	M20x1,5	40	4°	0,67	0,39	0,67	0,42
100	-	-	-	-	28	64	64	16	32	16 <sup>+0,5 +0,15</sup>	16	89	21	21	41	M16x1,5	32	4°	0,33	0,22	-	-
-	100	100	100	100	33	80	77	20	40	20 <sup>+0,6 +0,15</sup>	20	112	25	25	48	M20x1,5	40	4°	0,67	0,39	0,67	0,42
-	-	-	-	125	51	110	110	30	55	30 <sup>+0,6 +0,15</sup>	30	155	37	35	65	M27x2	54	4°	1,81	1,6	-	-
-	-	-	-	160	56	144	125	35	70	35 <sup>+0,6 +0,15</sup>	35	201	43	40	84	M36x2	72	4°	3,85	1,6	-	-
-	-	-	-	200	56	144	125	35	70	35 <sup>+0,6 +0,15</sup>	35	201	43	40	84	M36x2	72	4°	3,85	1,6	-	-



**FIXATION DE TIGE**

Compensateur d'alignement

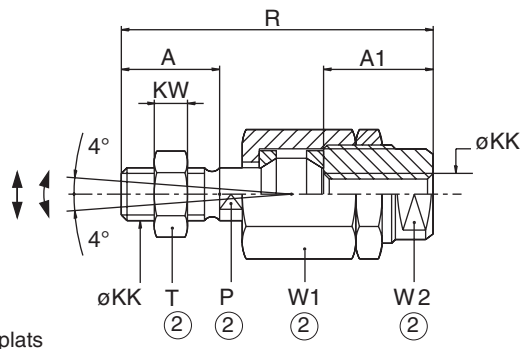

- ① Course
- ② Cote sur plats

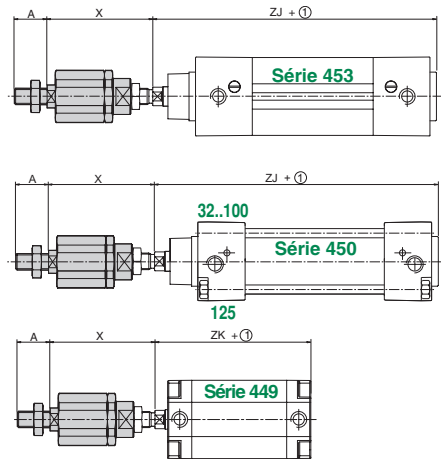

Ø (mm)	A	A1	P	ØKK	KW	R	T	W1	W2	X mini.	ZJ	ZK	compensation radiale (mm)	compensation angulaire sphérique (°)	masse													
449	-	-	●	-	●	-	●	-	●	-	●	-	●	-	●													
-	453	450	-	●	-	●	-	●	-	●	-	●	-	●	●													
20	-	-	16	-	18	-	7	-	M8x1,25	-	4	-	55	-	13	-	17	-	10	-	45	-	43	0,5	-	4	0,06	
25	-	-	16	-	18	-	7	-	M8x1,25	-	4	-	55	-	13	-	17	-	10	-	45	-	45	0,5	-	4	0,06	
32	32	32	20	20	22	22	12	12	M10x1,25	M10x1,25	5	5	71,5	71,5	16	16	30	30	19	19	57	57	120	51	0,7	0,7	4	0,22
40	40	40	22	24	26	23	12	12	M10x1,25	M12x1,25	6	7	73	75	17	19	30	30	19	19	58	57	135	52	0,7	0,7	4	0,23
50	50	50	24	32	26	32	12	20	M12x1,25	M16x1,5	7	8	77	103	19	24	30	41	19	27	59	79	143	53	0,7	1	4	0,66
63	63	63	24	32	26	32	12	20	M12x1,25	M16x1,5	7	8	77	103	19	24	30	41	19	27	59	79	158	57	0,7	1	4	0,66
80	80	80	32	40	34	39	19	20	M16x1,5	M20x1,5	8	10	106	119	24	30	42	41	30	27	82	89	174	64	1	1	4	0,7
100	100	100	32	40	34	39	19	20	M16x1,5	M20x1,5	8	10	106	119	24	30	42	41	30	27	82	89	189	77	1	1	4	0,7
-	125	-	54	-	40	-	24	-	-	M27x2	-	13,5	-	147	-	41	-	65	-	54	-	107	225	-	-	1	4	1,7

NOTE : Le compensateur est livré avec un jeu axial de 0,05 à 0,1 - Ne pas dérégler

Consulter notre documentation sur : [www.asco.com](http://www.asco.com)