

# Technical data

UPS2 15-40/50/60 130  
 UPS2 25-40/50/60 130  
 UPS2 PH-40/50/60

1 x 230 V, 50 Hz

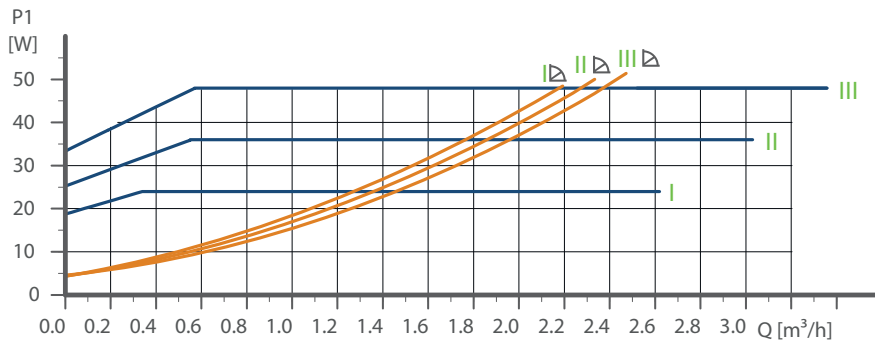
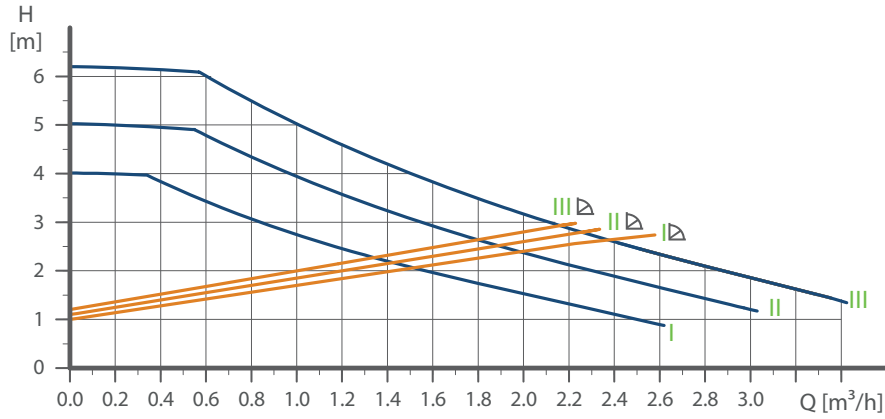

TM05 5403 3612

Speed	P <sub>1</sub> [W]	I <sub>1/I1</sub> [A]
Min.	7	0.06
Max.	48	0.42

Connections: See "Union and valve kits"  
 System pressure: Max. 10 bar.  
 Liquid temperature: +2 °C to +95 °C (TF 95).

The pump incorporates overload protection.

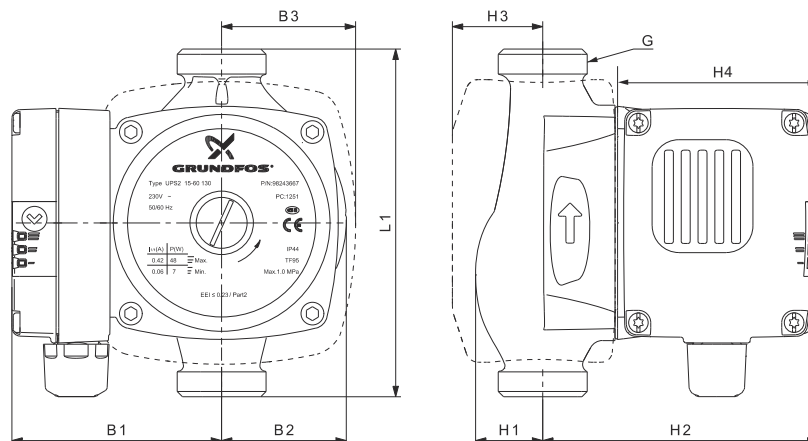

TM05 5202 3612

Pump type	EEI ≤	Dimensions [mm]							Weights [kg]		Ship. vol. [m <sup>3</sup> ]	Product number		
		L1	B1	B2	B3	H1	H2	H3	H4	G			Net	Gross
UPS2 15-40/50/60	0.23	130	79	51	87	28	102	79	76	1	2.5	2.7	0.004	98243667
UPS2 25-40/50/60	0.23	130	79	51	87	29	102	81	76	1 1/2	2.1	2.3	0.004	98243668
UPS2 PH-40/50/60	0.23	-	-	-	-	-	-	-	76	-	1.8	2	0.004	98334567

# Technical data

**UPS2 15-50/60 130**  
**UPS2 PH-50/60**

**1 x 230 V, 50 Hz**

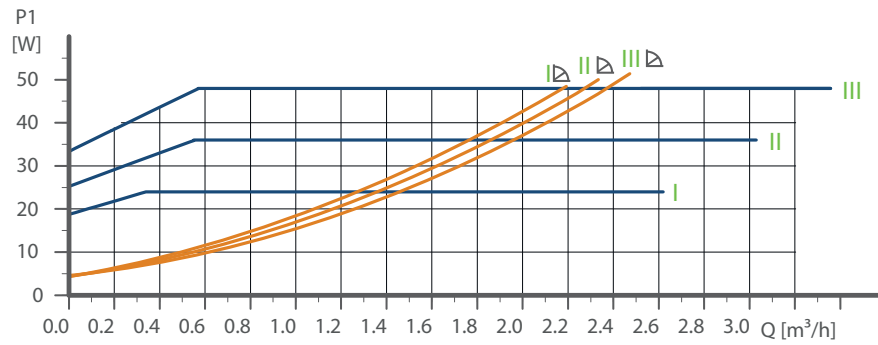
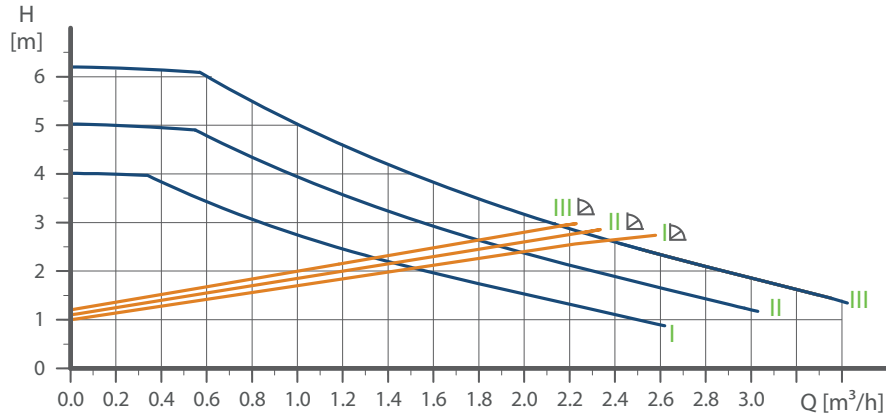

TM05 5403 3612

Speed	P <sub>1</sub> [W]	I <sub>1/1</sub> [A]
Min.	7	0.06
Max.	48	0.42

The pump incorporates overload protection.

Connections: See "Union and valve kits"  
System pressure: Max. 10 bar.  
Liquid temperature: +2 °C to +95 °C (TF 95).

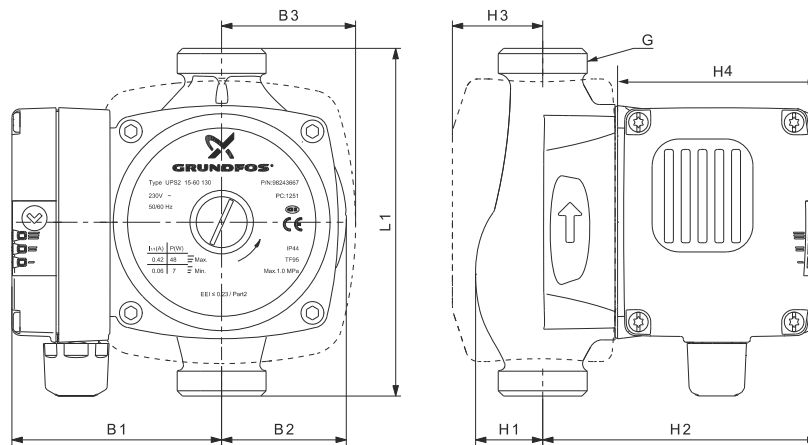

TM05 5202 3612

Pump type	Dimensions [mm]								Weights [kg]		Ship. vol. [m <sup>3</sup> ]	Product number		
	EEl ≤	L1	B1	B2	B3	H1	H2	H3	H4	G			Net	Gross
UPS2 15-50/60	0.23	130	79	51	87	29	102	81	76	1 1/2	2.65	2.85	0.004	98334549
UPS2 PH-50/60	0.23	-	-	-	-	-	-	-	76	-	1.8	2	0.004	98334563