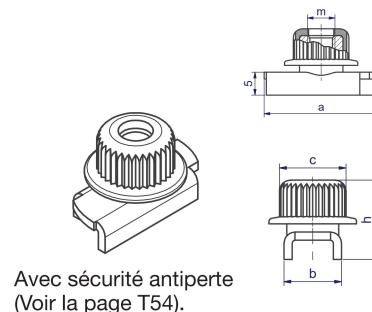
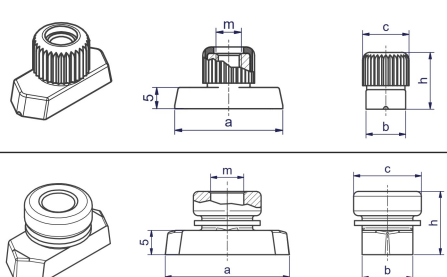
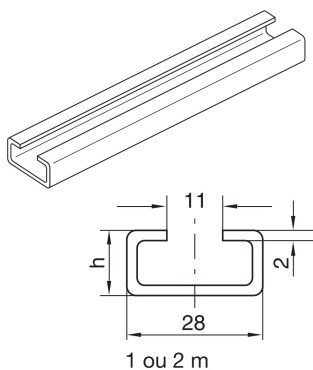

Colliers de serrage série B (colliers double) – Composants

DIN 3015, partie 3

 Avec sécurité antiperte
(Voir la page T54).

Dim. de collier	Support profilé		Ecrou de profilé support					Ecrou de profilé support						
	TS...A/B Référence	Dimension : h	TM Référence	Dimension :					TMA/TMB1... Référence	Dimension :				
				a	b	c	m	h		a	b	c	m	h
1			TMA/TMB1VERZX TMA/TMB1/4571X	25.4	10.4	12	M6	14.5	TMA/TMB1VERZX	25.4	10.4	12	M6	14.5
2	TS11A/B1...* TS11A/B2...* TS14A/B1...* TS14A/B2...* TS30A/B1...* TS30A/B2...*	TS11: 11 TS14: 14 TS30: 30	TMB2VZX TMB24571X	25.4	10.4	14	M8	13.0	TMB2VZX					
3														
4														
5														

*Référence raccord: compléter les références avec le suffix correspondant à la surface/matière choisie.

Références complémentaires		
Surface/matière	Suffix	Exemple
Acier, phosphaté	X	TS11A/B1X
Acier, zingué, sans Cr(VI)	VZX	TS11A/B1VZX
Acier inox 1.4571	4571X	TS11A/B171X