



uvex pheos faceguard

uvex faceguard



3 versions pour tous types de risques



Réf. 9790211



Réf. 9790212



Réf. 9790215

Concept : compact et ergonomique



- **Design compact** assurant une liberté de mouvement maximale
- Système à ressort pour un grand **confort de manipulation** de la visière
- Position parking épousant la forme du crâne pour conserver le centre de gravité de l'ensemble et **éviter les tensions cervicales**

Manipulation ultra-confortable

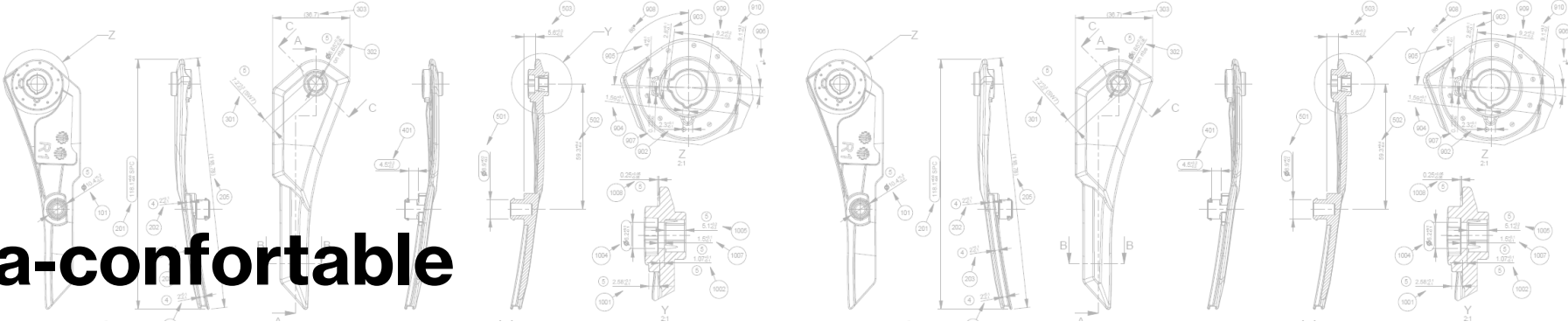

- Cinématique unique
- Mouvement semi-automatique avec système de ressorts
- Position parking ergonomique



Encombrement minimal

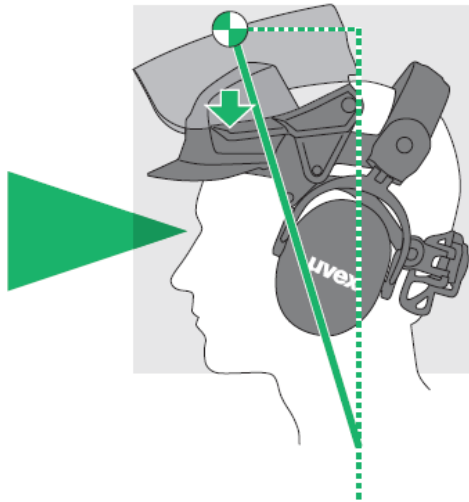

uvex pheos faceguard

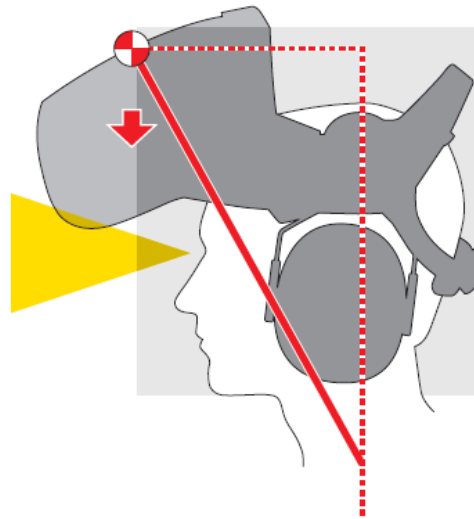
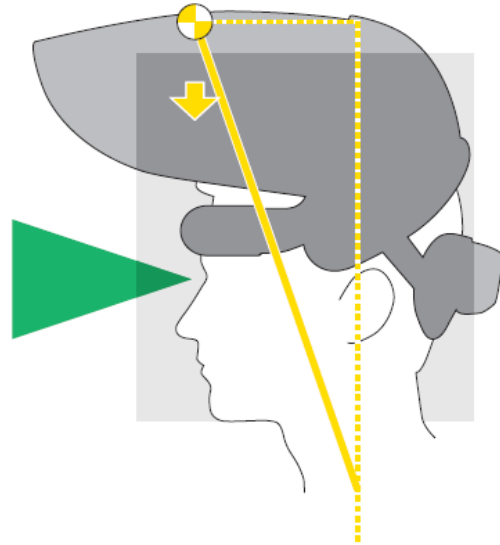

Produits concurrents

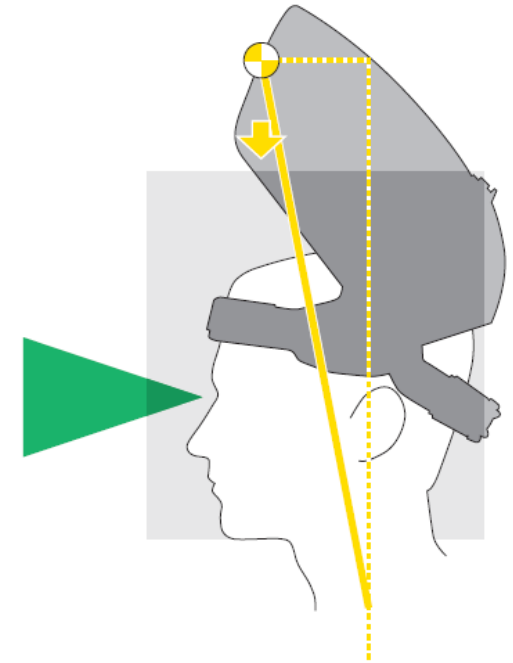



- **Visière en polycarbonate UV 400**, classe optique 1,
- résistance aux projections mécaniques **B**, résistance aux projections liquides **3**
- Résistance aux projections métaux fondus et solides chauds **9**
- Traitement uvex **supravision excellence** : puissant anti-buée sur face interne, résistance aux rayures et aux **produits chimiques** sur face externe (**K et N**)



uvex pheos faceguard



- **Coiffe intérieure ultra-confortable**
- Possibilité de **réglages** en hauteur et en largeur (52--64 cm)
- Bandeau anti-transpiration complet



- **Système uvex spiderneck**
- Repose nuque très confortable
- Maintien optimal

Version avec visière métal



Haute valeur de transmission de la visière > 60%

Modularité



**Compatible avec le port de lunettes de protection, de masque respiratoire, de coquilles anti-bruit
Coque EN 812 pour remplacer le port d'un casquette anti-heurt**

De nombreux accessoires

Visière
grillagée
Réf. 9790160



Protection
soleil/pluie
Réf. 9790074



Protection
anti-heurt
EN 812
Réf. 9790159



Cagoule contre
le froid
Réf.
9790065/9790068



Coquille anti-
bruit K1P
Réf. 2600216



Protection du
crâne et de la
nuque contre le
soleil
Ref. 9790170

Prêt à l'emploi !

- Système livré déjà monté
- 9790211 uvex pheos faceguard
Poids : 391g
- 9790212 uvex pheos faceguard
avec coquilles uvex K1P (28 dB)
Poids : 582g
- 9790215 uvex pheos faceguard forest
avec coquilles uvex K1P (28 dB)
Poids : 529g

