

- F Notice de montage ● GB Installation instructions
- E Manual de instalación ● I Istruzioni di montaggio
- NL Montage-instructies ● D Montageanleitung

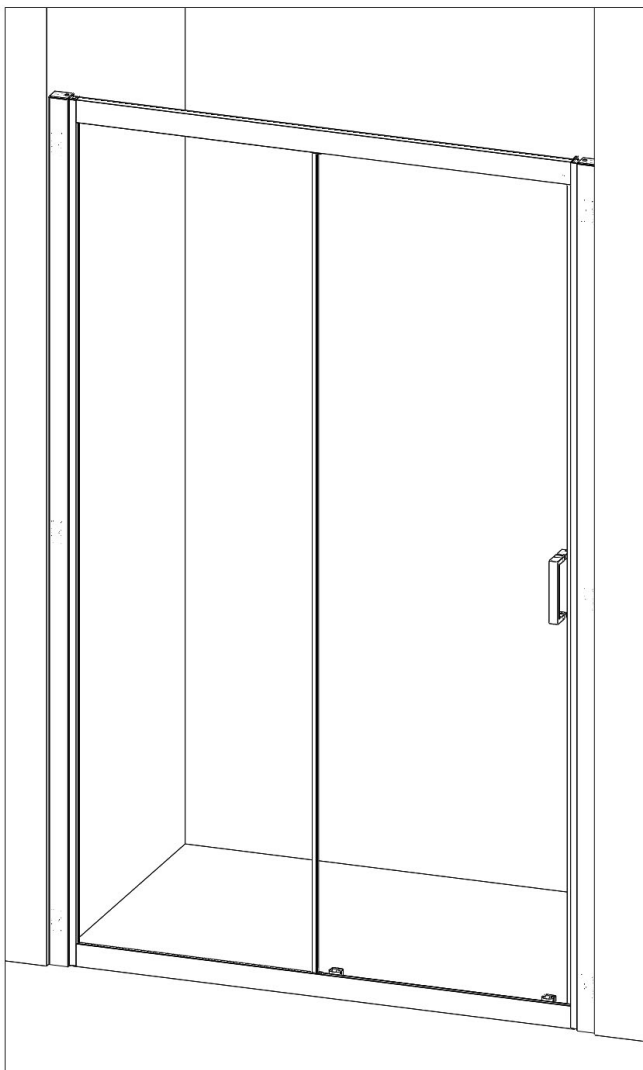

Notre service technique est  
à votre écoute aux numéros  
qui sont au dos de cette  
notice d'installation



- F Attention aux étapes :
- GB Check installation steps :
- E Atención a los pasos :
- I Attenzione ai passi :
- NL Aandacht voor de stappen :
- D Achtung vor den Schritten :

P. 8 - 13 - 23



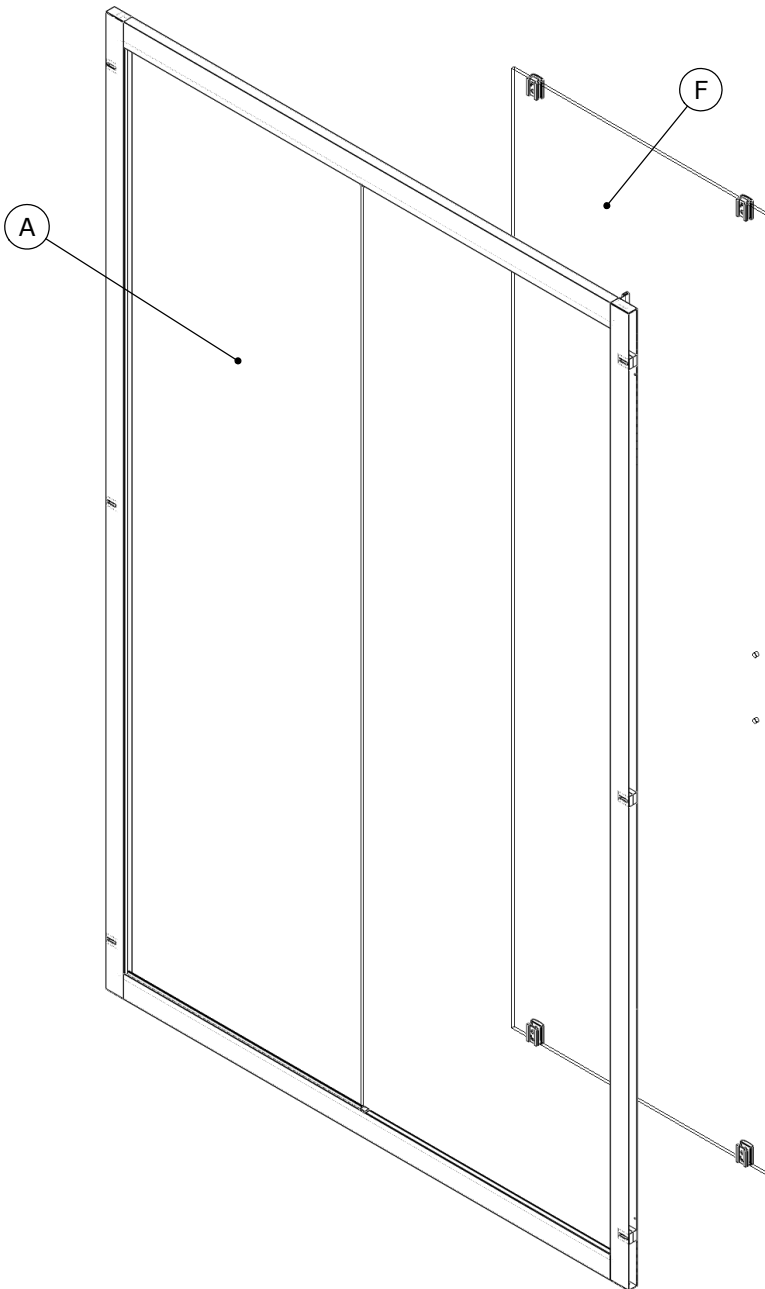

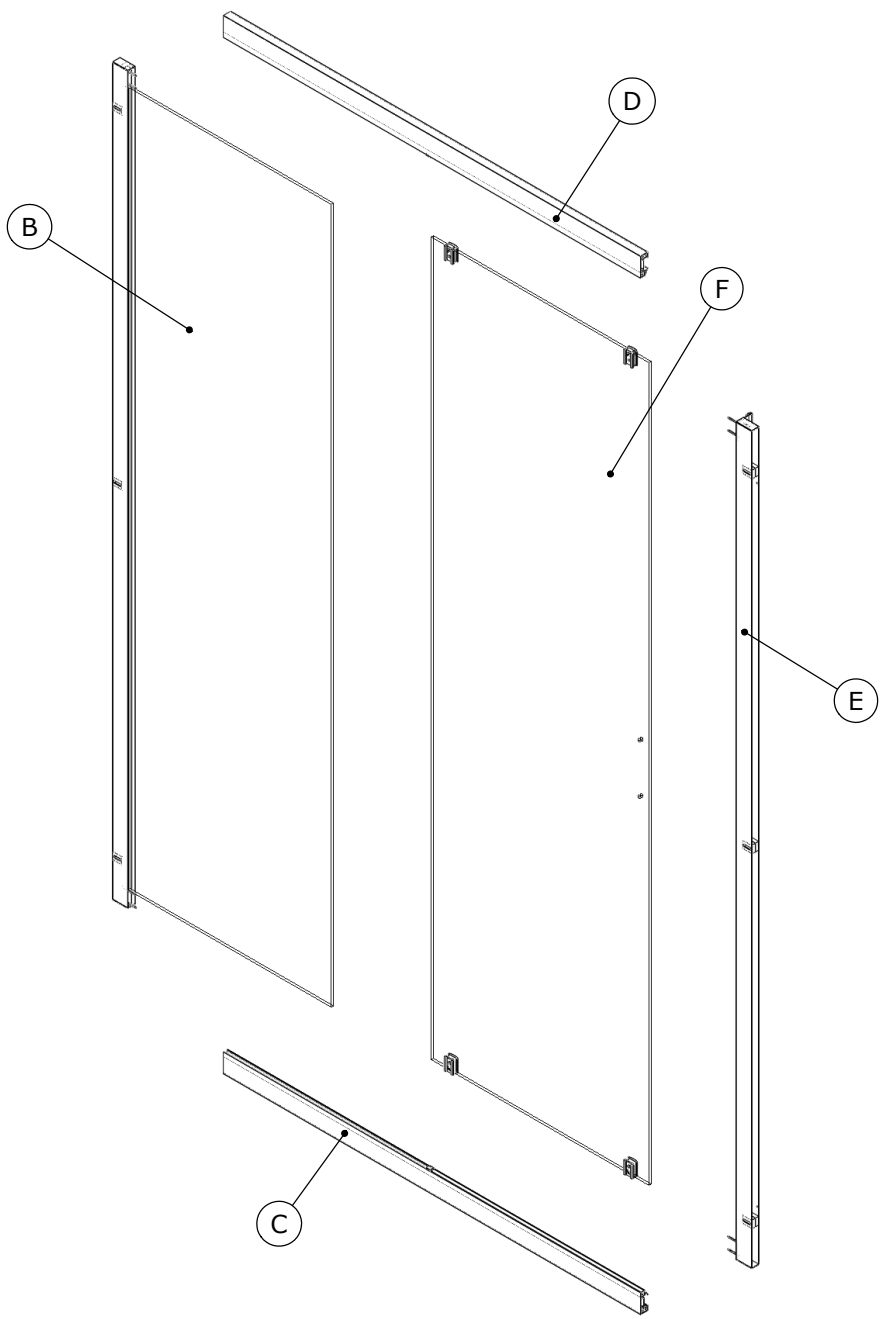

● Taille < 120 ● Size < 120  
● Medida < 120 ● Misura < 120  
● Afmetingen < 120 ● Größe < 120

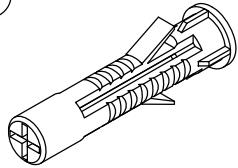
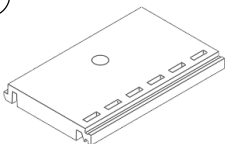
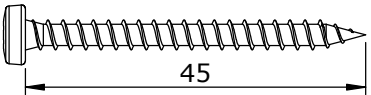
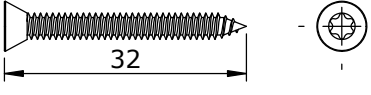

● Taille > 120 ● Size > 120  
● Medida > 120 ● Misura > 120  
● Afmetingen > 120 ● Größe > 120

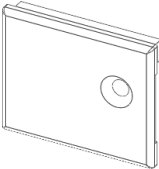
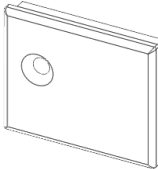
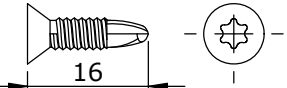
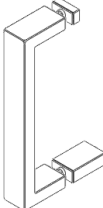
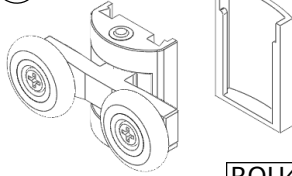
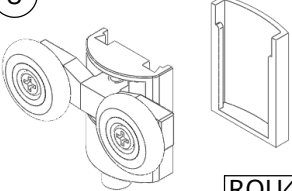

# DES1512B

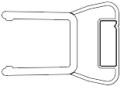
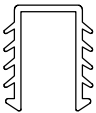
<p><b>J</b> <span style="float: right;">x2</span></p>  <p style="text-align: right;"><b>6242</b></p>	<p><b>K</b> <span style="float: right;">x6</span></p>  <p style="text-align: right;"><b>CHE02</b></p>	<p><b>L</b> <span style="float: right;">x6</span></p>  <p style="text-align: right;"><b>PPL1197</b></p>												
<p><b>M</b> <span style="float: right;">Ø4</span> <span style="float: right;">x6</span></p>  <p style="text-align: center;">45</p> <p style="text-align: center;"><b>1=1</b> <span style="float: right;"><b>VIS231</b></span></p>	<p><b>N</b> <span style="float: right;">Ø3.5</span> <span style="float: right;">x6</span></p>  <p style="text-align: center;">32</p> <p style="text-align: center;"><b>1=1</b> <span style="float: right;"><b>VIS255</b></span></p>													
<p><b>O</b> <span style="float: right;">x2</span></p>  <p style="text-align: right;"><b>6243</b></p>	<p><b>P</b> <span style="float: right;">x1</span></p>  <p style="text-align: right;"><b>PPL1199</b></p>	<p><b>Q</b> <span style="float: right;">x1</span></p>  <p style="text-align: right;"><b>PPL1200</b></p>												
<p><b>R</b> <span style="float: right;">Ø3.5</span> <span style="float: right;">x2</span></p>  <p style="text-align: center;">16</p> <p style="text-align: center;"><b>1=1</b> <span style="float: right;"><b>VIS296</b></span></p>	<p><b>S</b> <span style="float: right;">x1</span></p>  <p style="text-align: right;"><b>PGN47</b></p>	<p><b>T</b> <span style="float: right;">x2</span></p>  <p style="text-align: right;"><b>ROU46</b></p>												
<p><b>U</b> <span style="float: right;">x2</span></p>  <p style="text-align: right;"><b>ROU47</b></p>	<p><b>V</b> <span style="float: right;">x1</span></p>  <p style="text-align: right;"><b>Lg=1864mm</b> <span style="float: right;"><b>J887</b></span></p>	<p><b>W</b> <span style="float: right;">x1</span></p>  <p style="text-align: right;"><b>Lg=1799mm</b> <span style="float: right;"><b>J886</b></span></p>												
<p><b>X</b> <span style="float: right;">x1</span></p>  <table border="1" data-bbox="44 1428 229 1548"> <tr><td>900</td><td>Lg=290mm</td></tr> <tr><td>1000</td><td>Lg=340mm</td></tr> <tr><td>1100</td><td>Lg=390mm</td></tr> <tr><td>1200</td><td>Lg=440mm</td></tr> <tr><td>1300</td><td>Lg=490mm</td></tr> <tr><td>1400</td><td>Lg=540mm</td></tr> </table> <p style="text-align: right;"><b>JOI303</b></p>	900	Lg=290mm	1000	Lg=340mm	1100	Lg=390mm	1200	Lg=440mm	1300	Lg=490mm	1400	Lg=540mm	<p><b>Y</b> <span style="float: right;">x1</span></p>  <p style="text-align: right;"><b>AI192</b></p>	<p><b>Z</b> <span style="float: right;">x2</span></p>  <p style="text-align: right;"><b>T. ≥ 120cm</b> <span style="float: right;"><b>JOI301</b></span></p>
900	Lg=290mm													
1000	Lg=340mm													
1100	Lg=390mm													
1200	Lg=440mm													
1300	Lg=490mm													
1400	Lg=540mm													

Les quantités données sont les quantités utiles au montage, les sachets fournis contiennent des pièces supplémentaires.  
The quantities given are what are required for the installation. There may be some surplus in the package provide.

● Outillage nécessaire ● Tools required ● Equipamiento necesario  
 ● Attrezzatura necessaria ● Benodigde gereedschap ● Werkzeuge erforderlich

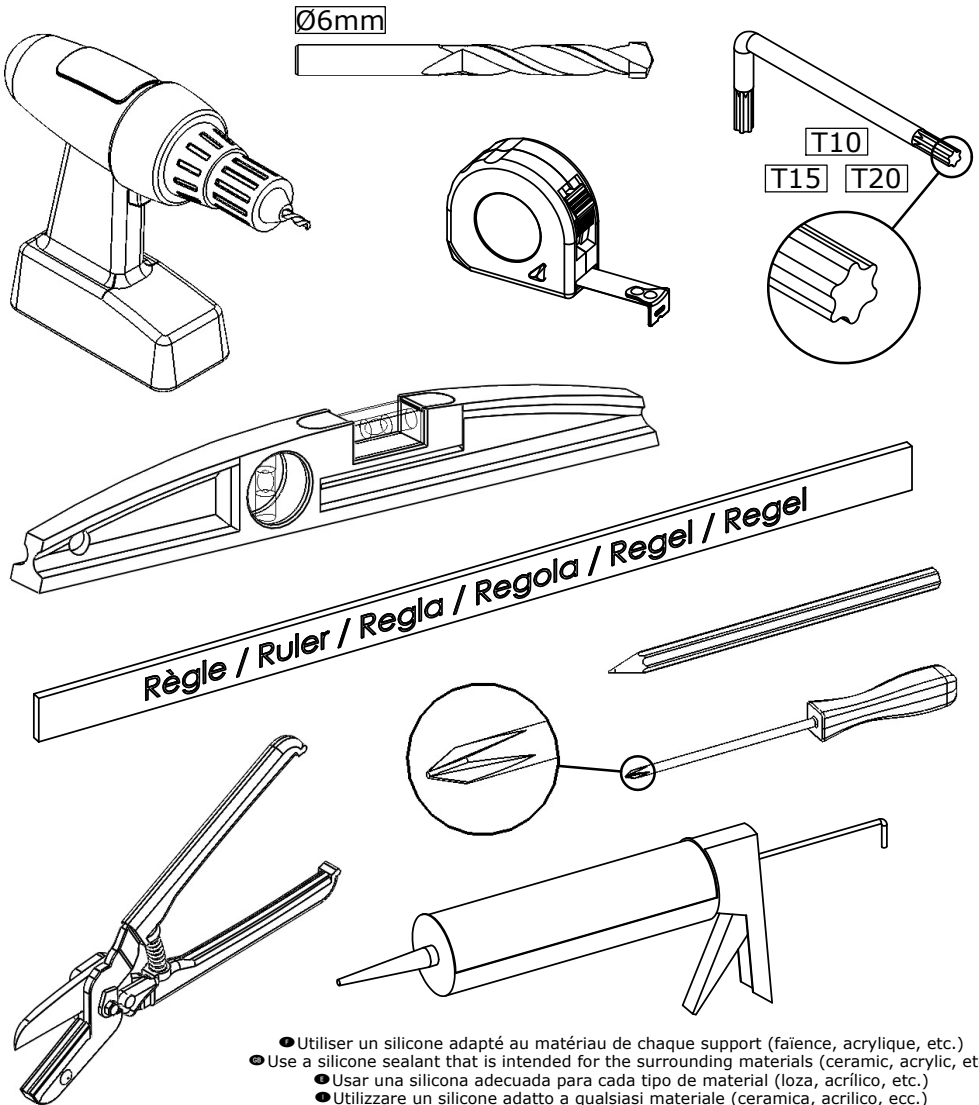

- Utiliser un silicone adapté au matériau de chaque support (faïence, acrylique, etc.)
- Use a silicone sealant that is intended for the surrounding materials (ceramic, acrylic, etc.)
- Usar una silicona adecuada para cada tipo de material (loza, acrílico, etc.)
- Utilizzare un silicone adatto a qualsiasi materiale (ceramica, acrilico, ecc.)
- Gebruik siliconenkit die geschikt is voor iedere ondergrond (tegelwerk, acryl, etc.)
- Für das jeweilige Trägermaterial (Stein, Acryl usw.) geeignetes Silikon verwenden.



● Réversibilité ● Reversibility ● Reversibilidad  
 ● Reversibilida ● Omkeerbaarheid ● Wahlweise Montage

● Montage à gauche  
 ● Left hand  
 ● Montaje a la izquierda  
 ● Montaggio a sinistra  
 ● Montage links  
 ● Montage links

● Montage à droite  
 ● Right hand  
 ● Montaje a la derecha  
 ● Montaggio a destra  
 ● Montage rechts  
 ● Montage rechts

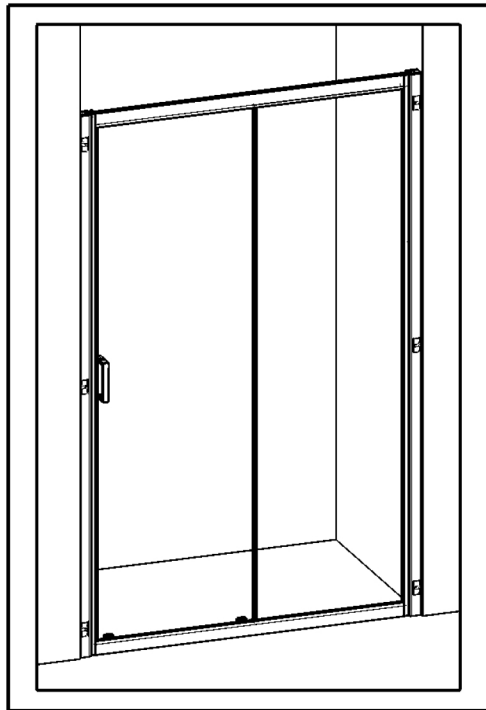
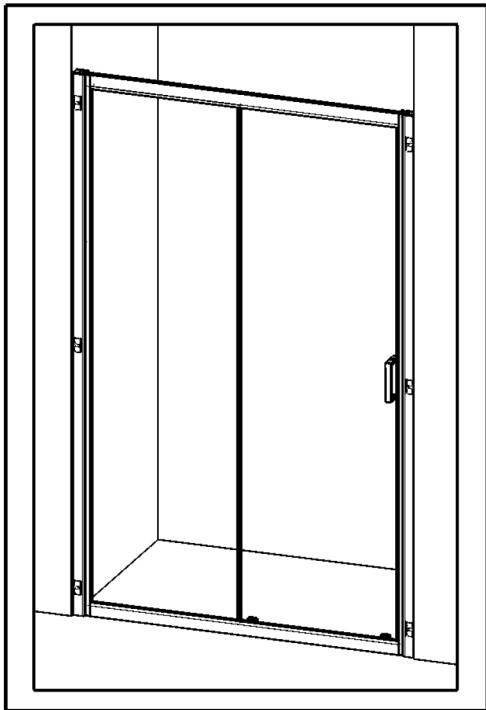

● Vous avez la possibilité de réaliser un montage à droite ou un montage à gauche. Notre notice d'installation décrit un montage à gauche. Si vous voulez réaliser un montage à droite, il vous suffit d'inverser le montage.

● This cubicle can be installed either left or right hand. These installation instructions show a left hand installation.

● Puede realizar un montaje a la derecha o un montaje a la izquierda. Nuestro folleto de instalación describe un montaje a la izquierda. Si desea montar su cabina a la derecha sólo tendrá que realizar el montaje al contrario.

● Avete la possibilità di effettuare il montaggio a destra o a sinistra. Il nostro manuale descrive il montaggio a sinistra. Se volete realizzare il montaggio a destra è sufficiente invertire varie fasi di montaggio.

● U kunt de douchecabine rechts of links monteren. Onze handleiding beschrijft de links montage van de cabine. Keer de montage om als u de cabine rechts wilt monteren.

● Sie haben die Möglichkeit, eine Montage auf der linken Seite oder eine Montage auf der rechten Seite durchzuführen. Unsere Montageanleitung beschreibt eine Montage auf der linken Seite. Wenn Sie die Montage lieber auf der rechten Seite durchführen wollen, müssen Sie nur den Montageprozess umkehren.



- Cas particulier : Montage par l'intérieur
- Special case : Mounting from the inside
- Caso especial : Montaje desde el interior
- Caso speciale : Montaggio dall'interno
- Speciaal geval : Montage van binnenuit
- Sonderfall : Montage von innen

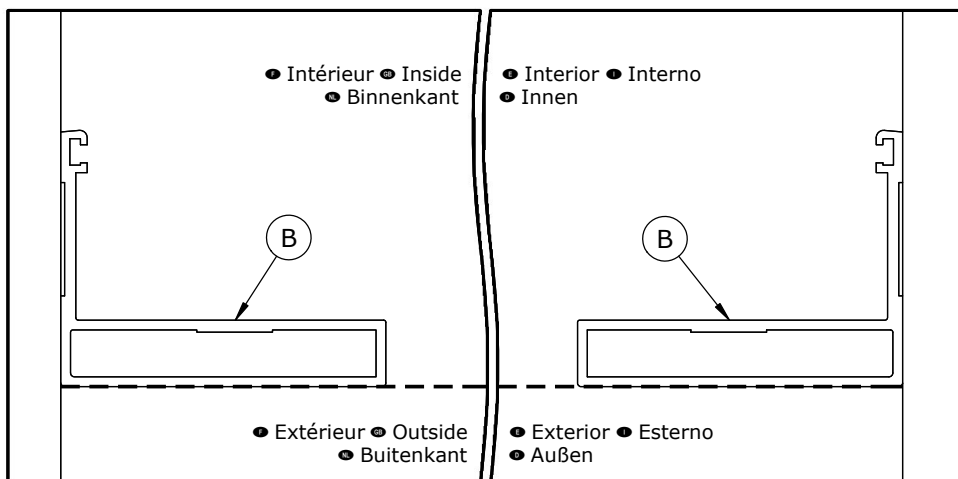
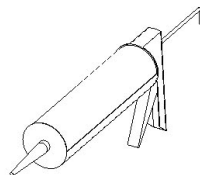
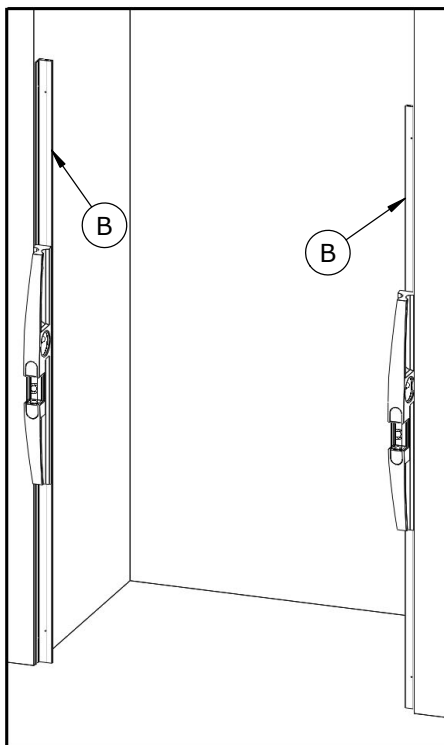

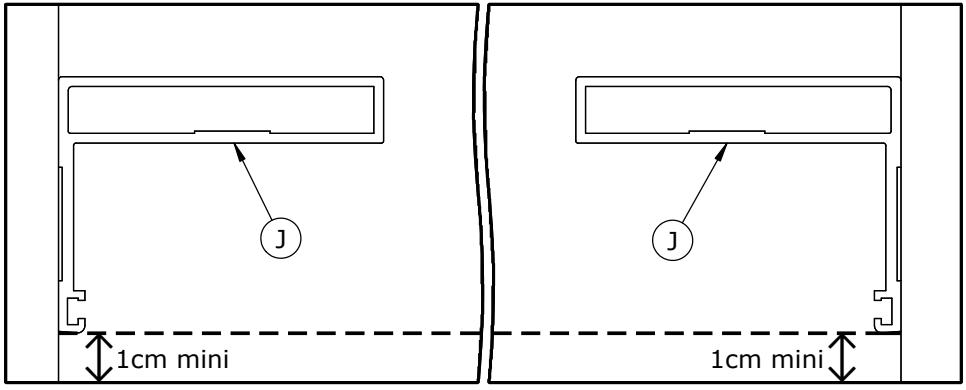
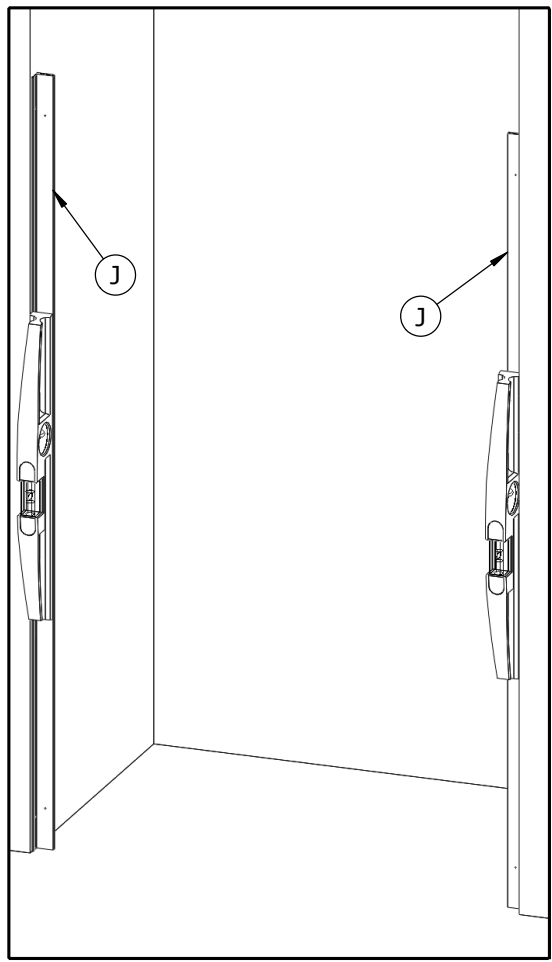



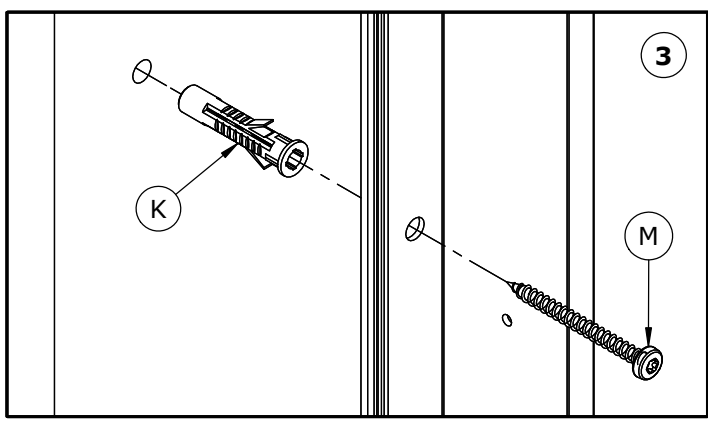
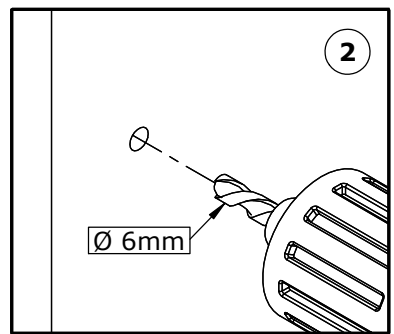
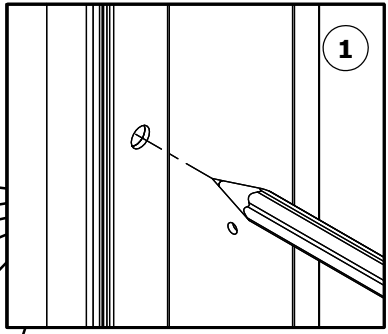
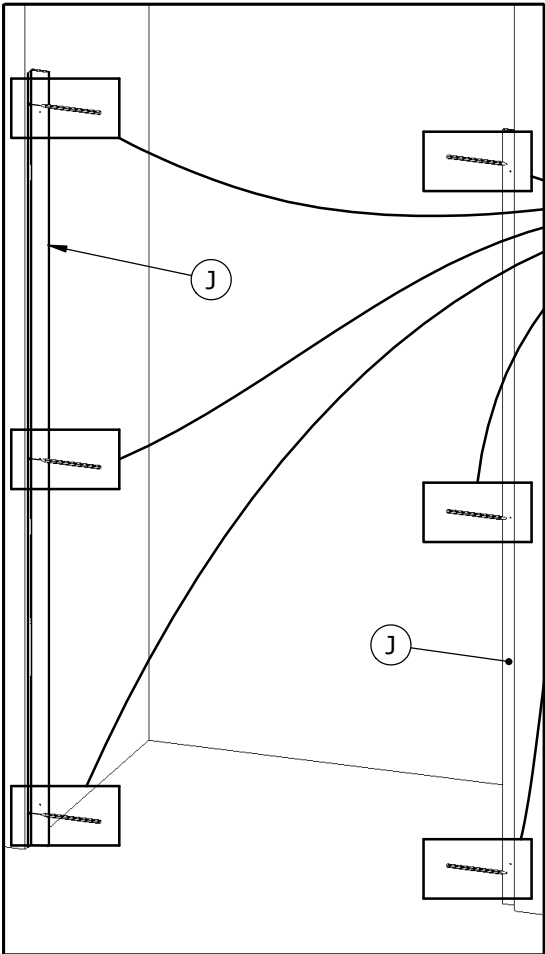

- Taille > 120
- Size > 120
- Medida > 120
- Misura > 120
- Afmetingen > 120
- Größe > 120

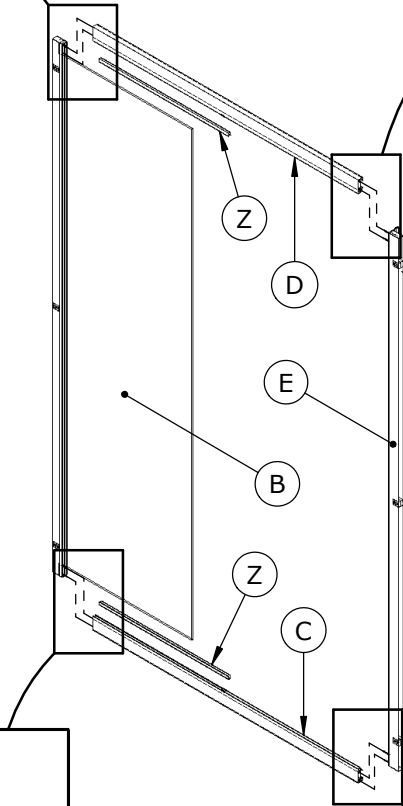
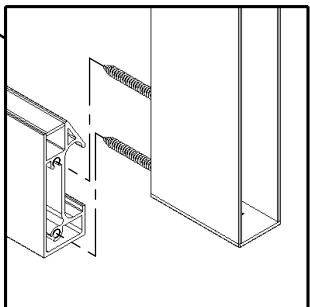
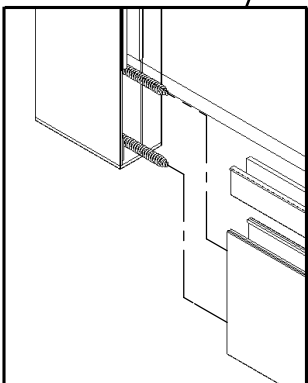
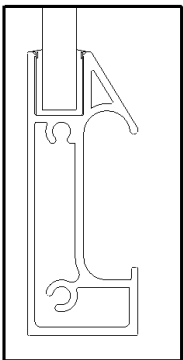
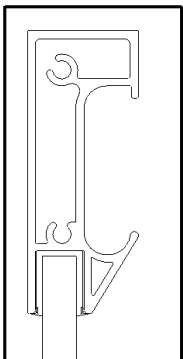
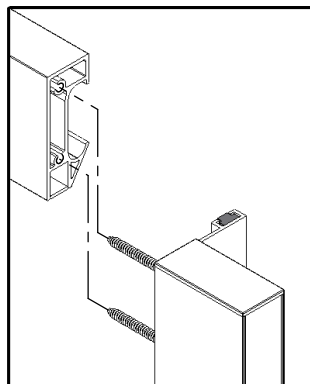
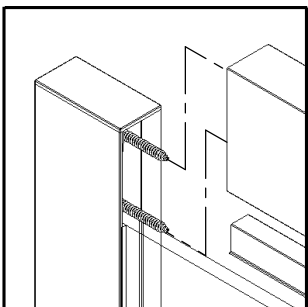

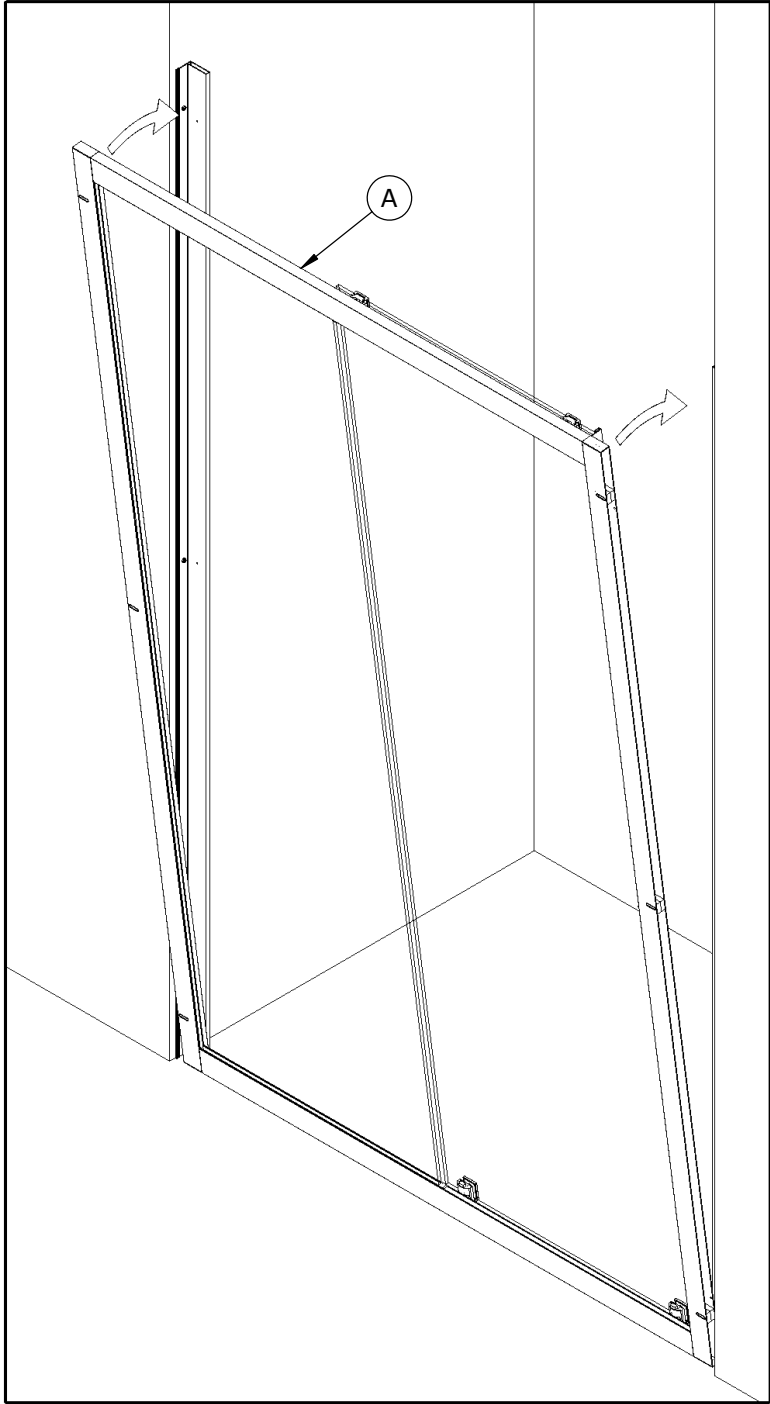

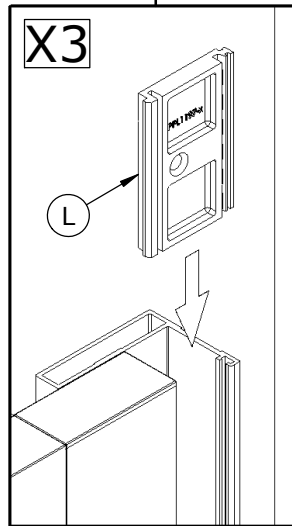
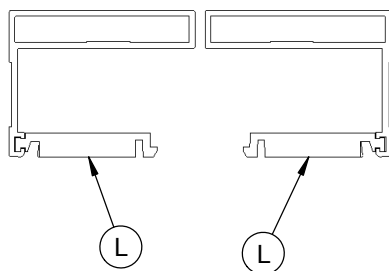
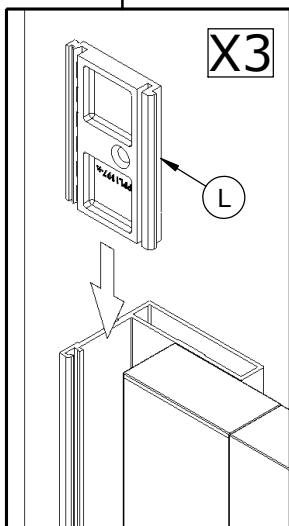
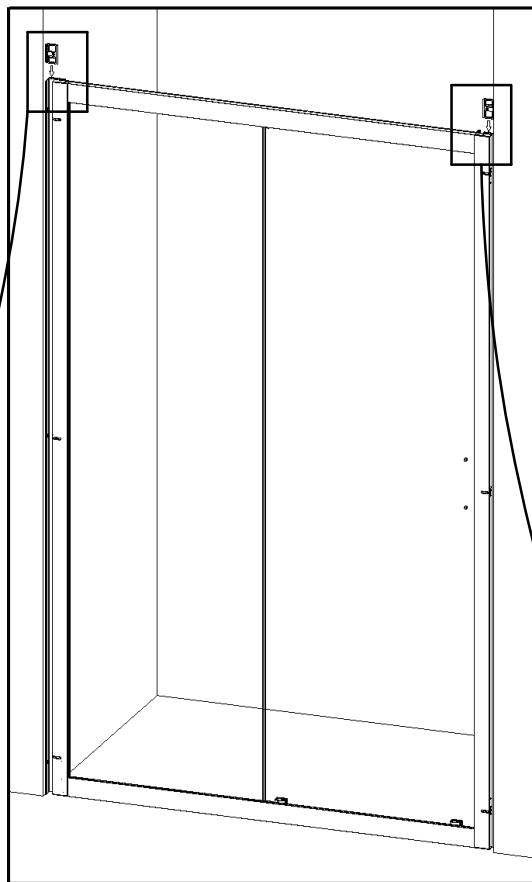

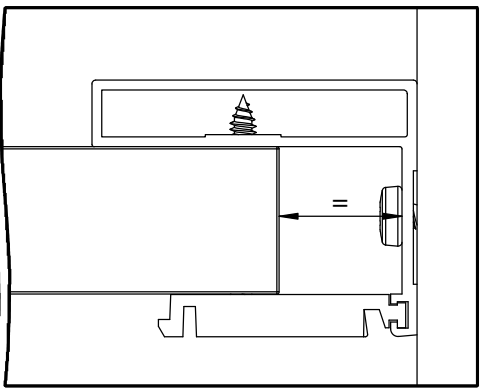
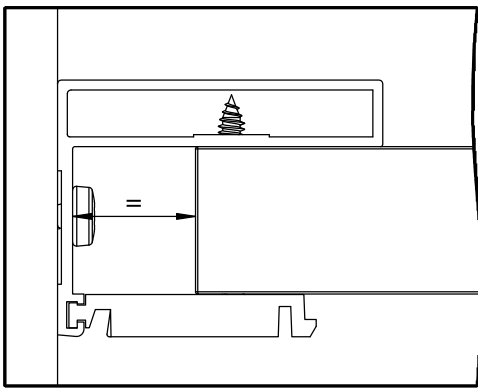
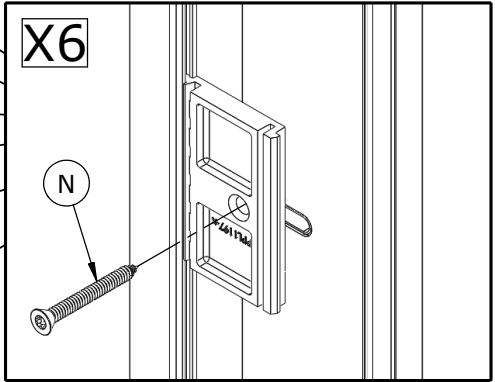
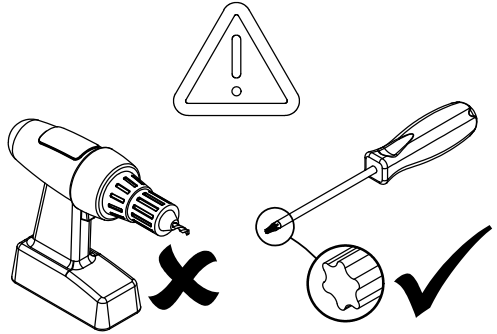
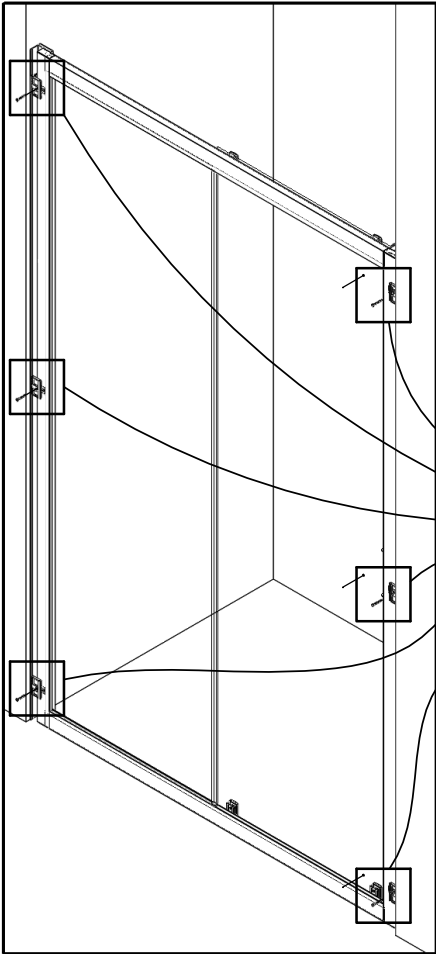

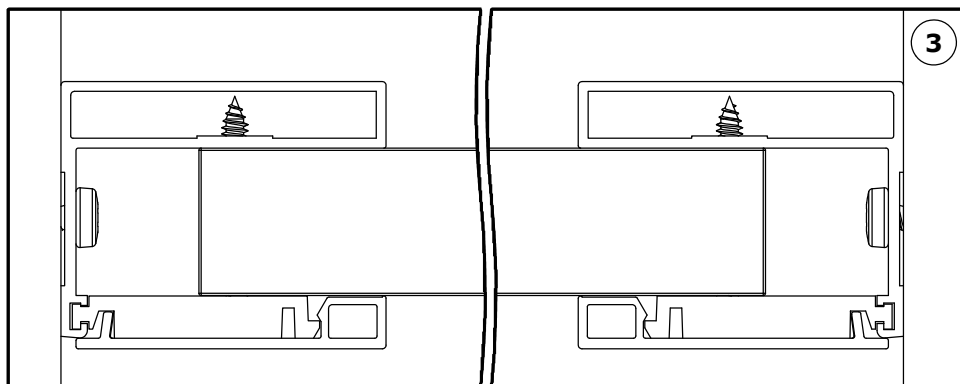
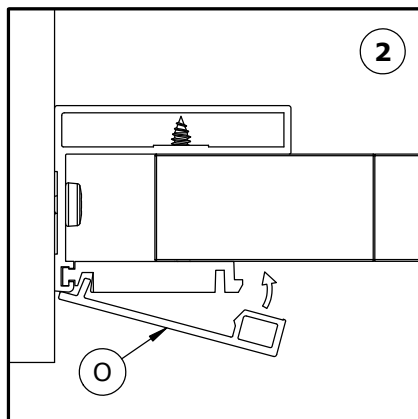
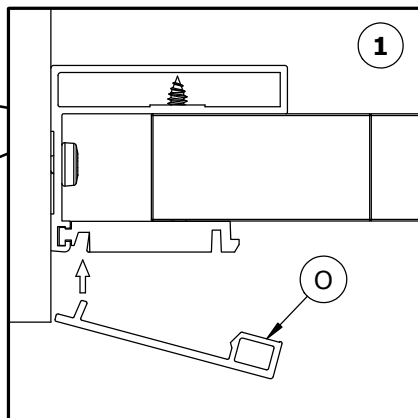
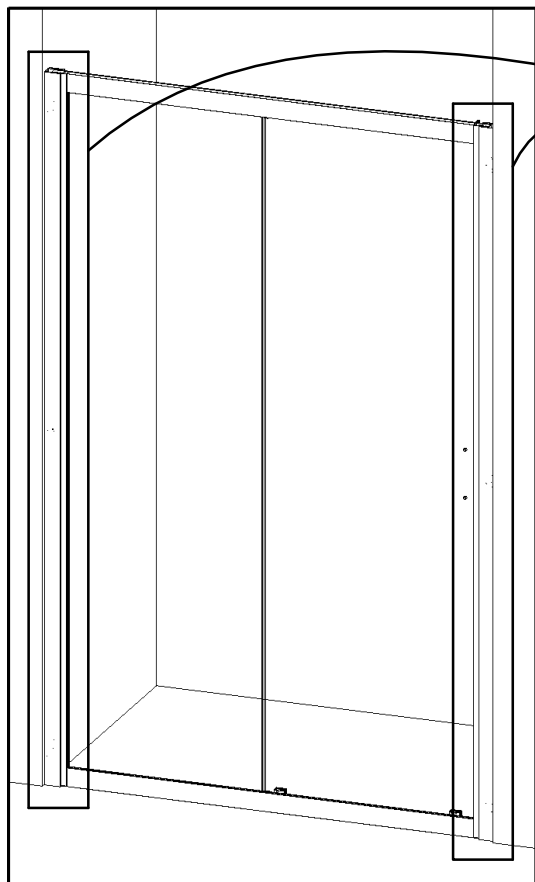

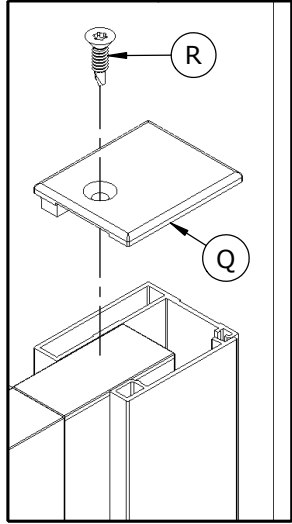
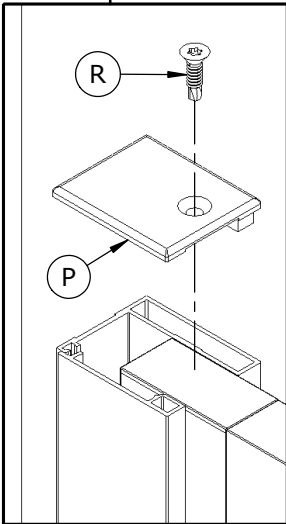
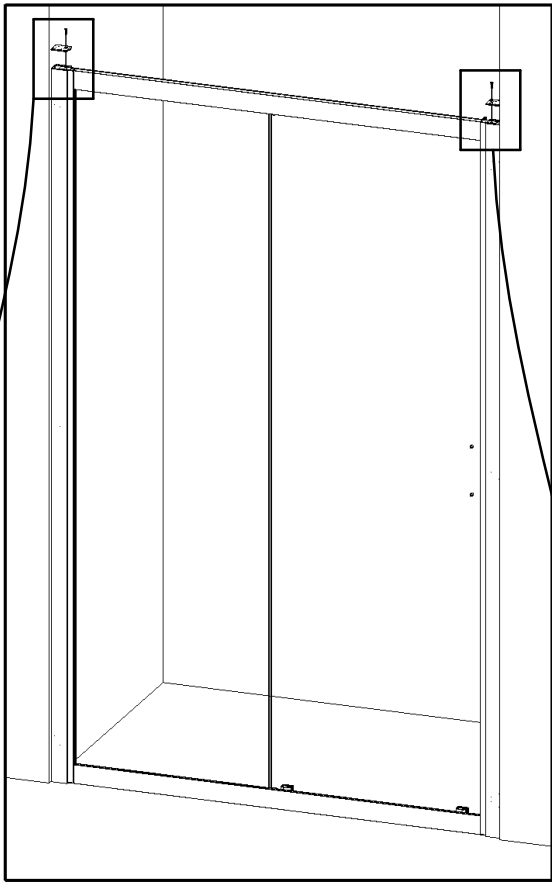

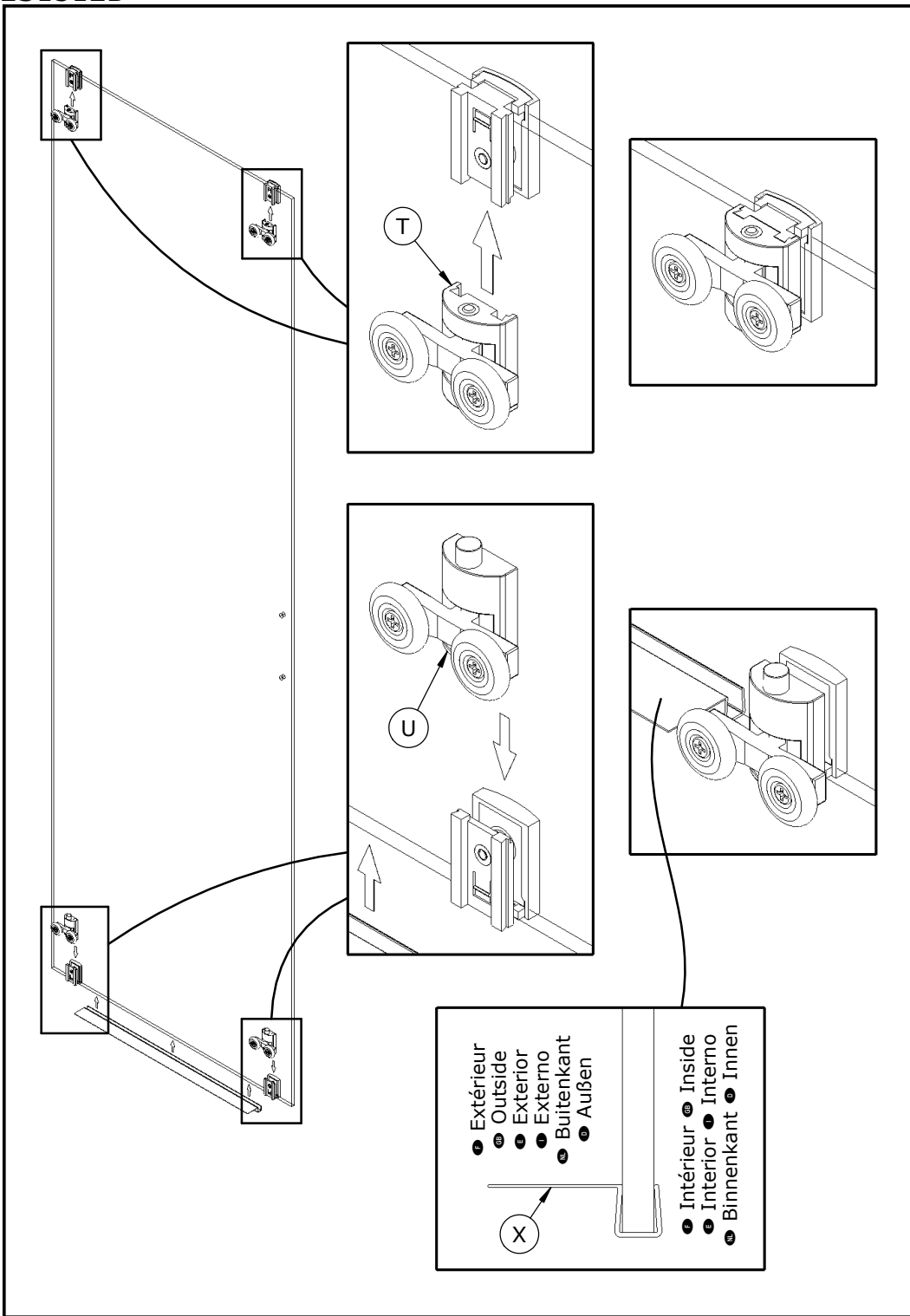

- |   |            |   |            |
|---|------------|---|------------|
| ● | Extérieur  | ● | Intérieur  |
| ● | Outside    | ● | Inside     |
| ● | Exterior   | ● | Interior   |
| ● | Externo    | ● | Interno    |
| ● | Buitenkant | ● | Binnenkant |
| ● | Außen      | ● | Innen      |
- X →



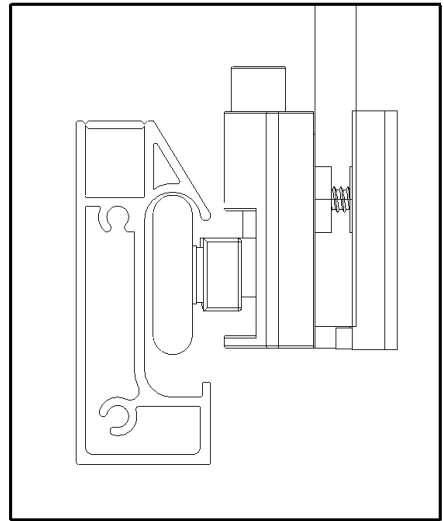
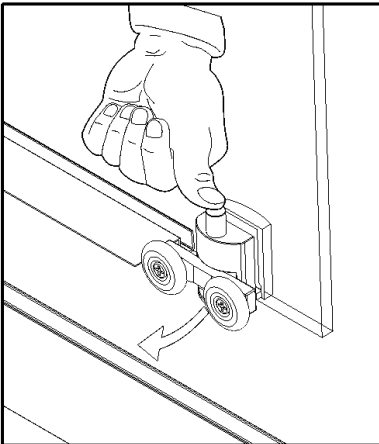
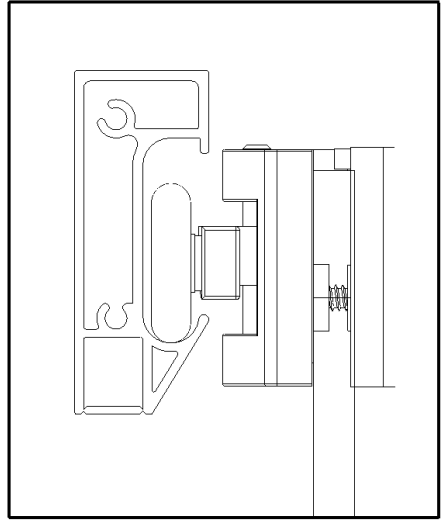
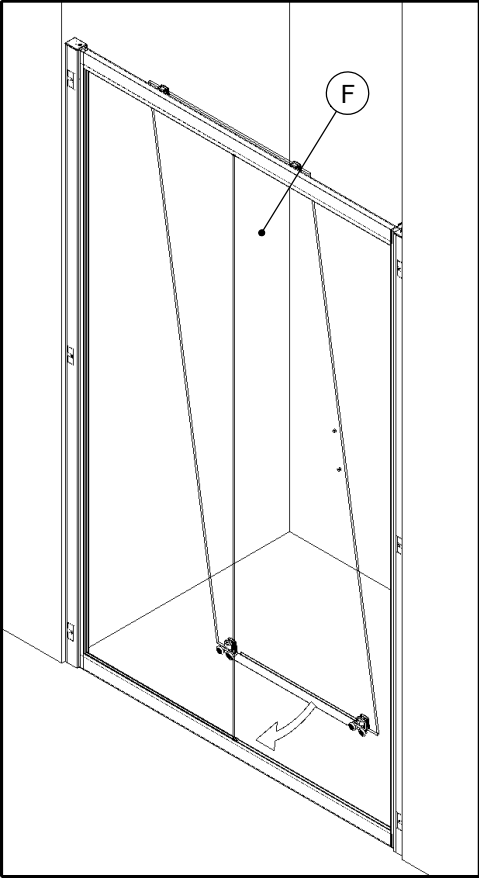

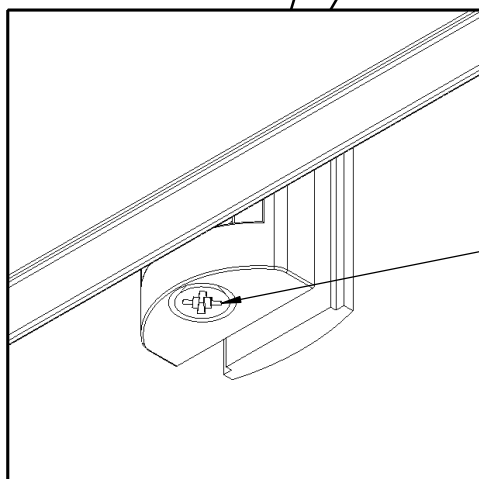
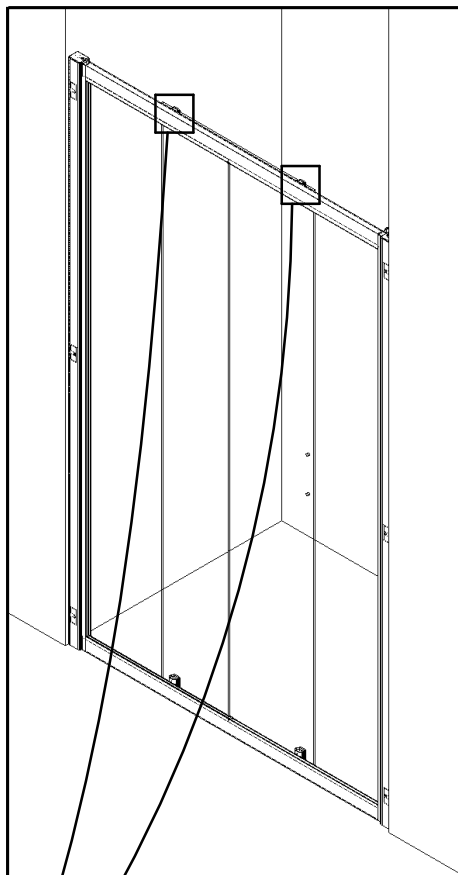

- Régler les portes afin qu'elles soient de niveau
- Ⓢ Adjust the doors so that they are level
- Ajustar las puertas de manera que estén niveladas
- Regolare le porte in modo che siano in bolla
- Ⓢ Stel de deuren zodanig af zodat ze waterpas staan
- Türen waagrecht ausrichten

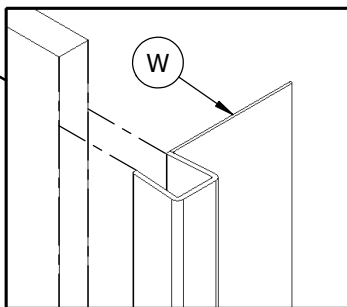
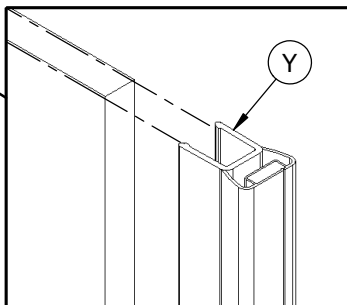
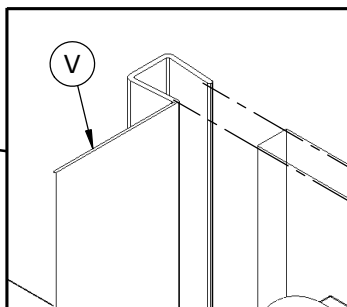
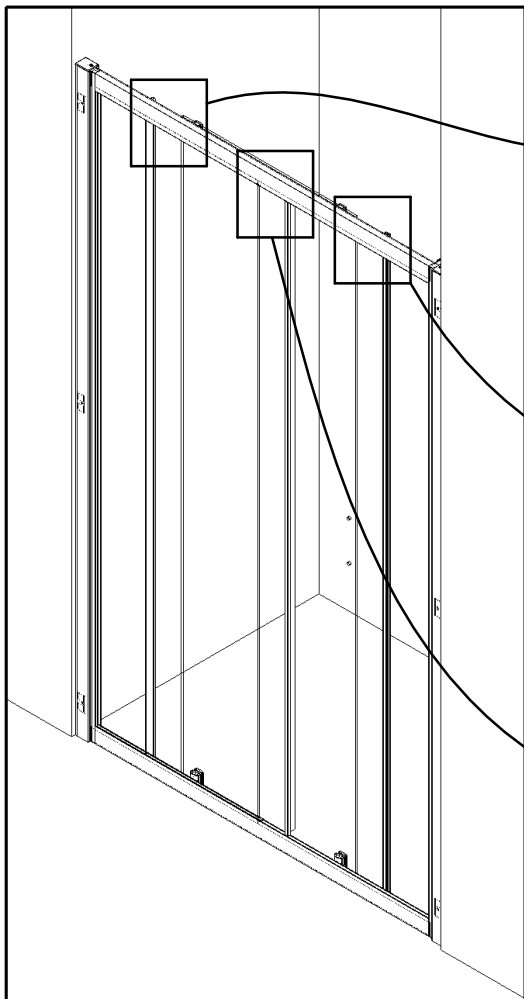

● Couper si nécessaire ● Cut if necessary ● Recortar si necesario  
 ● Tagliare si necessario ● Snijden indien nodig ● Bei Bedarf zuschneiden

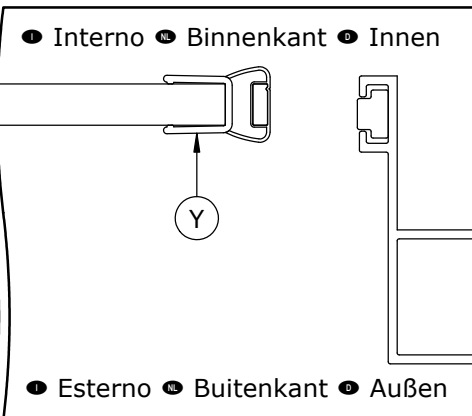
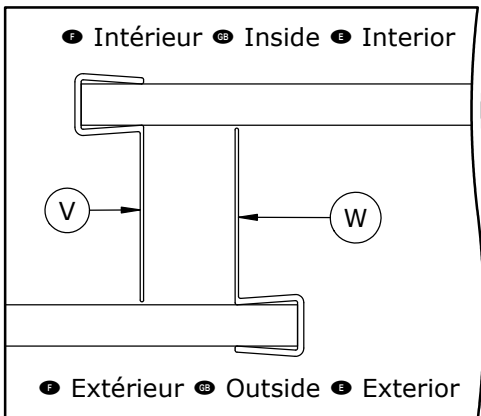

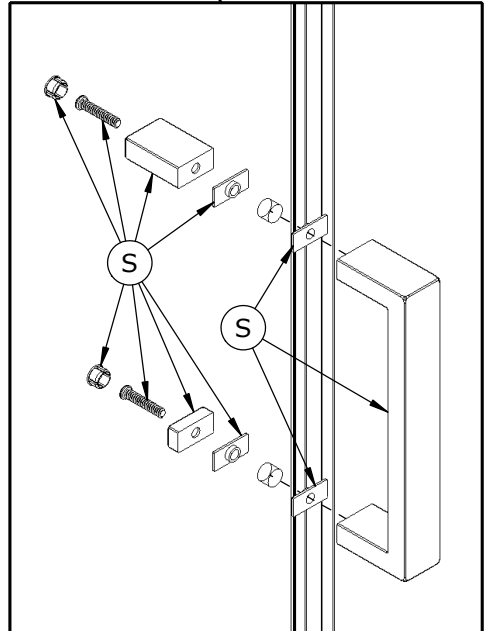
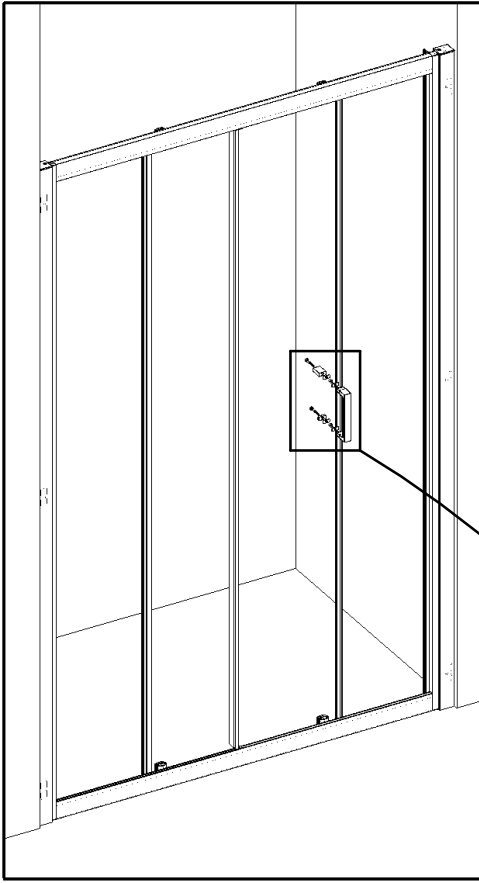

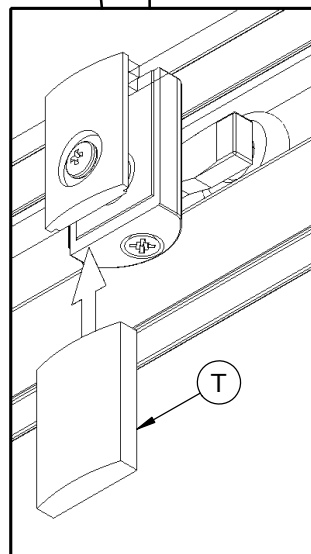
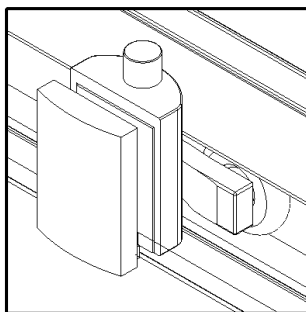
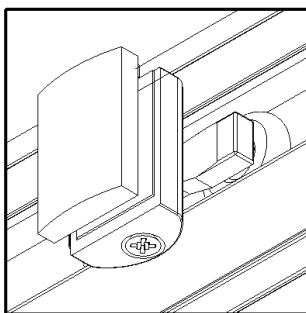
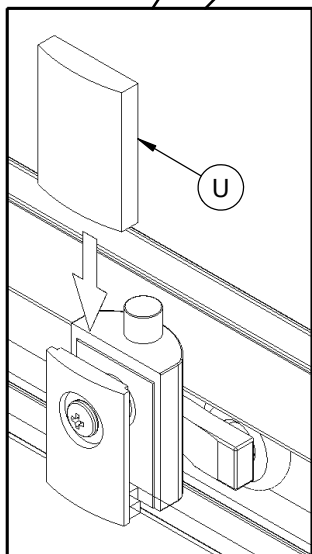
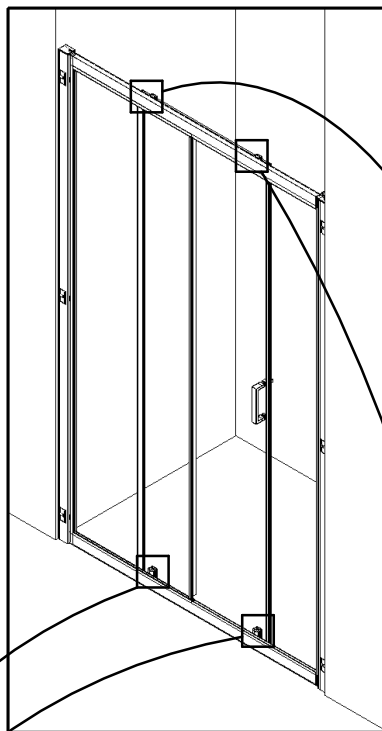

● U Vue intérieure ● C Interior view ● B Vista interior  
 ● T Vista interna ● B Binnen aanzicht ● B Innenansicht

- ⓕ Cas particulier : Montage par l'intérieur
- Ⓢ Special case : Mounting from the inside
- ⓔ Caso especial : Montaje desde el interior
- Ⓛ Caso speciale : Montaggio dall'interno
- Ⓝ Speciaal geval : Montage van binnenuit
- Ⓞ Sonderfall : Montage von innen

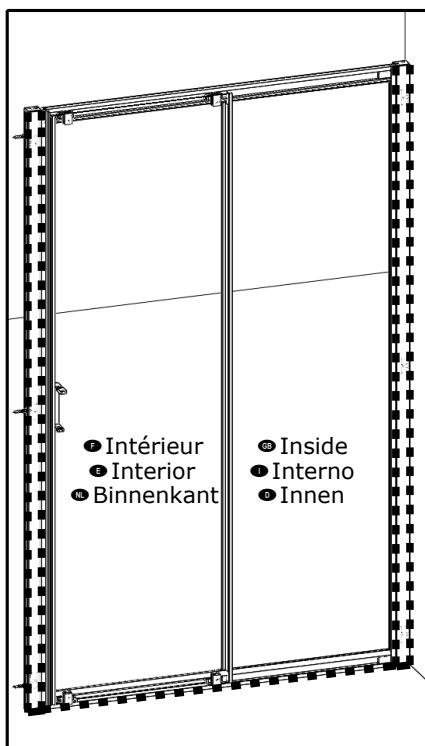

- ⓕ Détail du siliconage
- Ⓢ Detail of the siliconization
- ⓔ Detalle de la siliconización
- Ⓛ Dettaglio della siliconizzazione
- Ⓝ Detail van de siliconisatie
- Ⓞ Detail der Silikonisierung

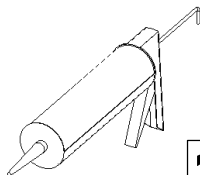
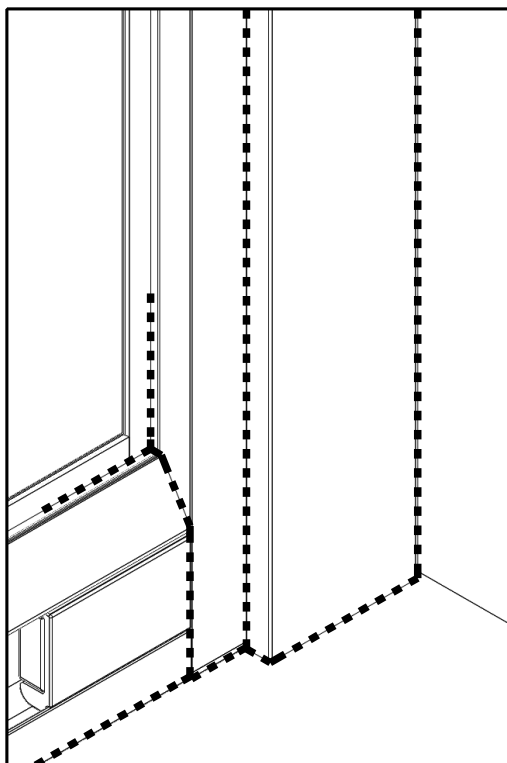

24H



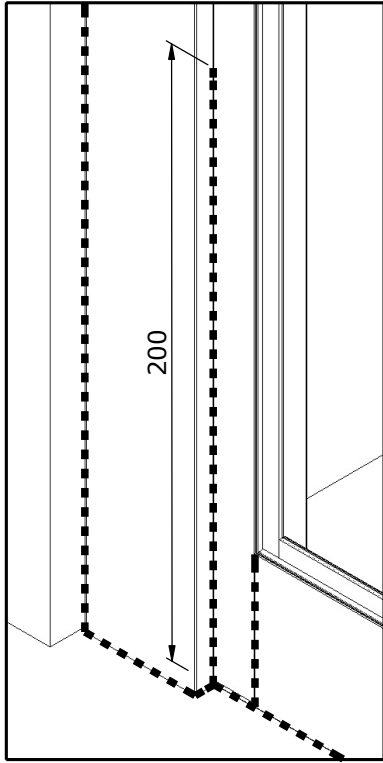
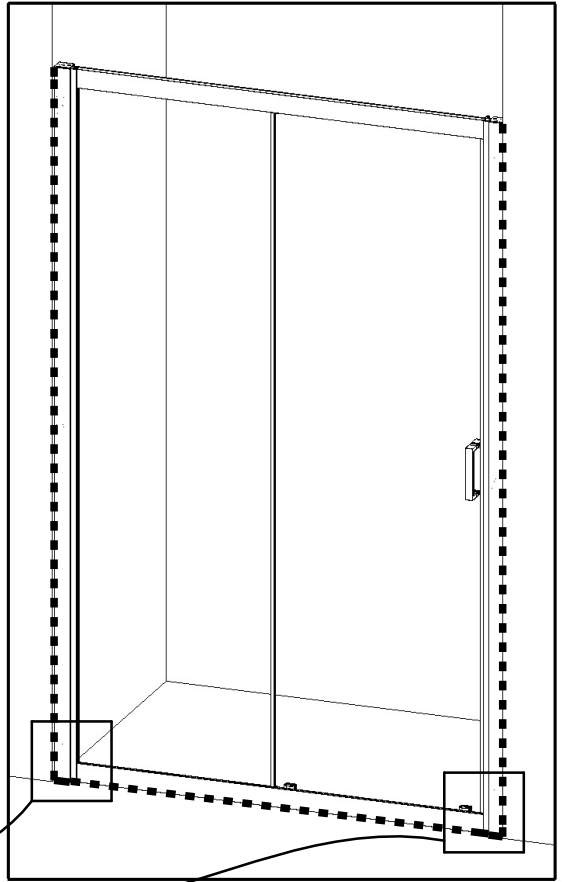
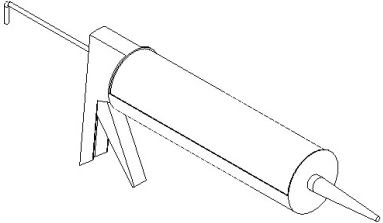

24H



**SAV**  
**SERVICE HELPLINES**  
**ASSISTENZA POST-VENDITA**  
**SERVICIO POSTVENTA**

**FRANCE**

02 40 21 29 45

**UK**

020 8842 0033

**IRELAND**

04697 33102

**DEUTSCHLAND**

+49 (0) 6074 / 30928 0

**ITALIA**

(0382) 6181

**ÖSTEREICH**

+43 1 710 60 70

**SCHWEIZ**

(01) 748 17 44

**ESPAÑA**

93 544 60 76

**NEDERLAND**

+31 475 487 100

**BELGIË**

+31 475 487 100

**BELGIQUE**

+31 475 487 100

**РОССИЯ**

963 19 40, 773 67 22

**PORTUGAL**

219 112 785



AQUAPRODUCTION, Site industriel,  
 F - 44680 Chaumes-en-Retz

21

**EN 14428**

Paroi de douche, fabriquée en verre de silicate  
 sodo-calcique de sécurité trempé thermiquement

Aptitude au nettoyage : réussite

Résistance à l'impact/propriétés de fragmentation : réussite

Durabilité : réussite