

# LEDA

## NOTICE DE MONTAGE POUR

## ARTY

PAROI FIXE POUR MONTAGE AVEC PORTE / RÉVERSIBLE  
MONTAGE EN ANGLE AVEC PORTE : PIVOTANTE /  
PIVOTANTE AVEC PARTIE FIXE EN LIGNE

Vitrage transparent - Profilés argent brillant, satiné, blanc ou noir mat

**DOCUMENT A CONSERVER / DOCUMENT TE BEWAREN**

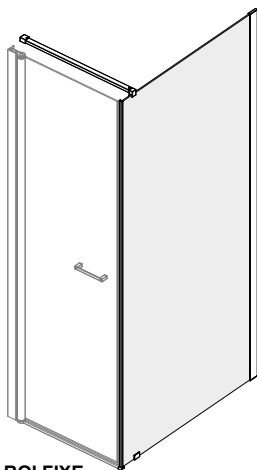

PAROI FIXE  
POUR PORTE PIVOTANTE

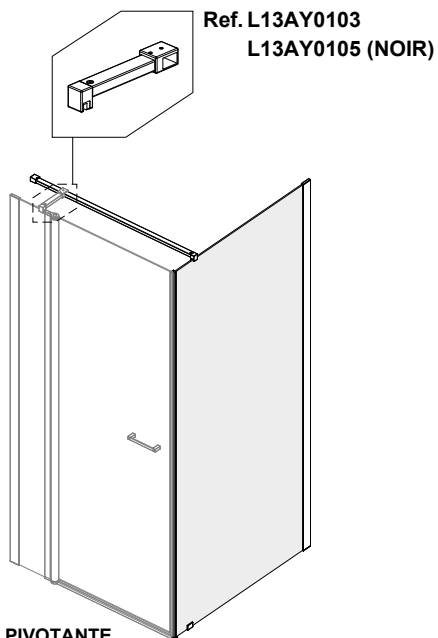

PAROI FIXE  
POUR PORTE PIVOTANTE  
AVEC PARTIE FIXE

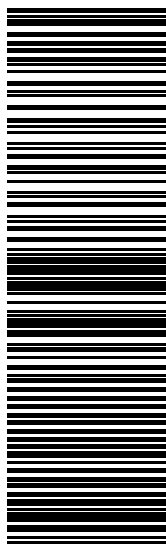

(01) 2000002074997 (94) AL LBlank

La société LEDA se réserve le droit d'apporter des modifications techniques sans préavis.

**NOTICE A CONSERVER PAR L'UTILISATEUR DU PRODUIT**  
***INSTRUCTIES TE BEWAREN DOOR DE CONSUMENT***

**LEDA : Z.A. Du Bois Gasseau - CS 80004 SAMOREAU - 77215 AVON CEDEX**  
**TEL : 01 60 71 66 41 - FAX : 01 60 71 66 49**

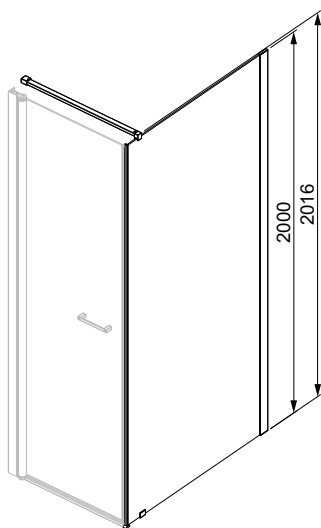

## PAROI FIXE POUR PORTE PIVOTANTE

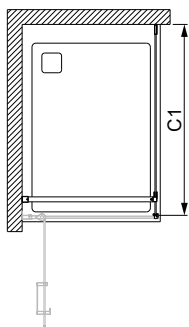

Paroi Fixe	C1min-max [mm]
70	638-668
75	688-718
80	738-768
90	838-868
100	938-968

## Ref. L13AY0103 L13AY0105 (NOIR)

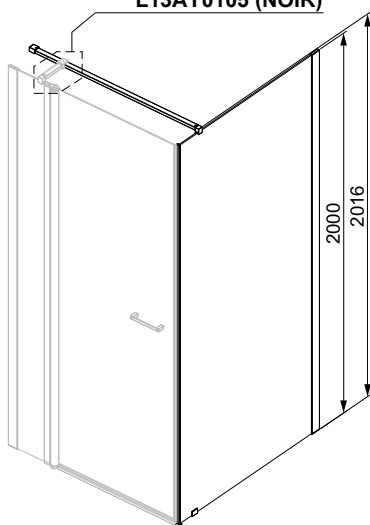

## PAROI FIXE POUR PORTE PIVOTANTE AVEC PARTIE FIXE

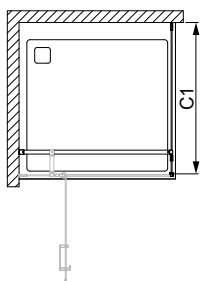

Paroi Fixe	C1min-max [mm]
70	638-668
75	688-718
80	738-768
90	838-868
100	938-968



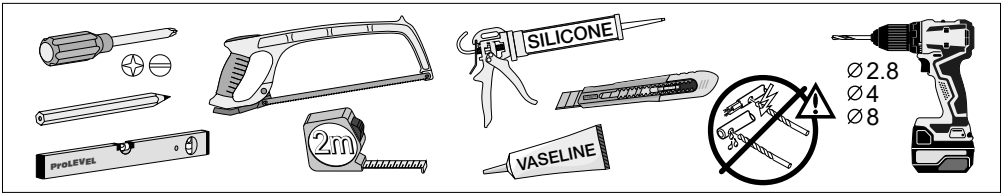

## ENTRETIEN

**NE PAS UTILISER DE PRODUITS ABRASIFS** pour nettoyer la paroi

### NOTICE:

- Lire attentivement la notice avant installation. Vérifier tous les éléments de la liste cidessus.
- Préparez toutes les pièces et les outils dont vous aurez besoin et installer le produit en suivant les étapes d'instructions.

## ONDERHOUD

**Gebruik geen agressieve, schurende onderhoudsproducten voor de reiniging van het scherm.**

### Notitie

- Lees aandachtig de handleiding alvorens aan te vangen met de montage. Kijk na of alle onderdelen van onderstaande lijst aanwezig zijn.
- Leg alle materialen en werkgerief klaar en start met de installatie door de verschillende stappen van het montagevoorschrift te volgen.

Etapes du montage en fonction du type de produit

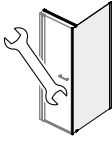
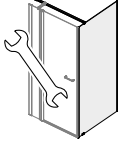
PAROI FIXE POUR PORTE PIVOTANTE	PAROI FIXE POUR PORTE PIVOTANTE AVEC PARTIE FIXE
 <p>A1 A2 A3 A4 A5 A6 A7 A8 A9 A10 A11</p>	 <p>B1 B2 B3 B4 B5 B6 B7 B8 B9 B10 B11 B12</p>

A1 / B1

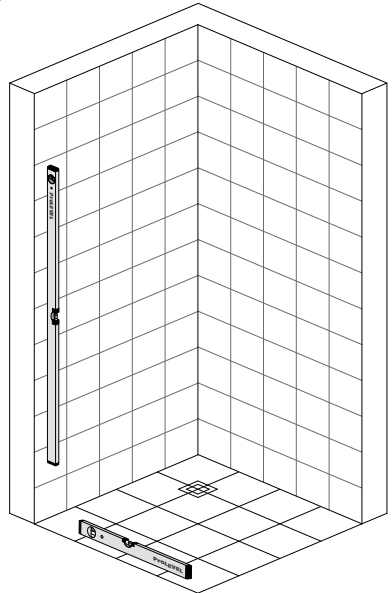
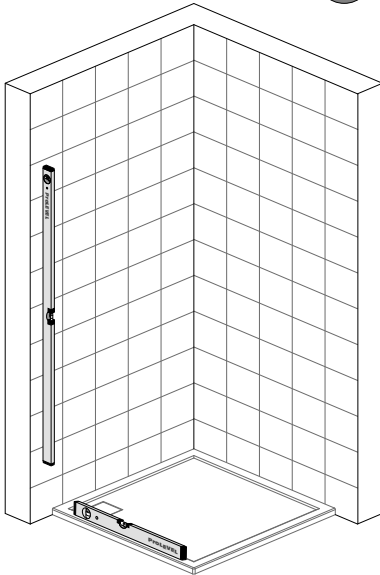

A2

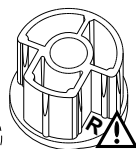
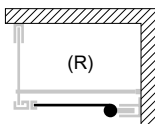
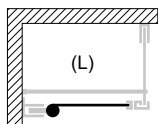
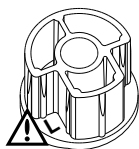

L

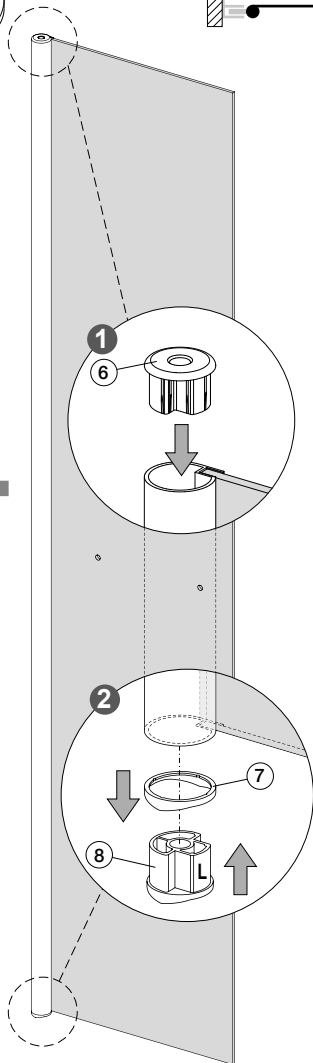

R

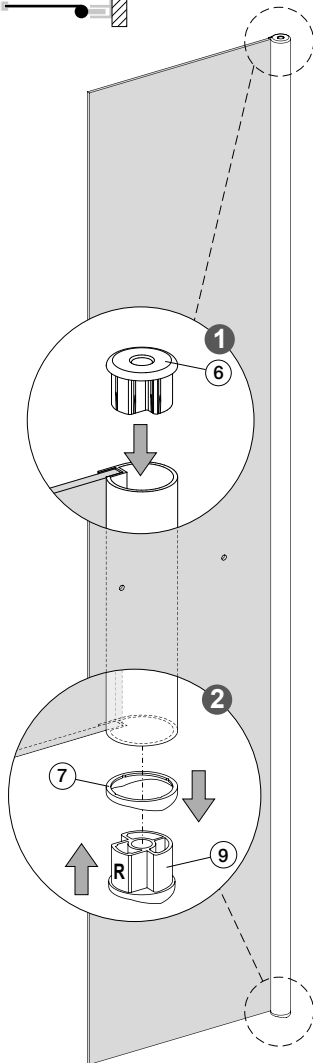

**A3**

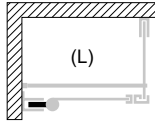

pour faciliter le coulissement mettre du liquide vaisselle, savon ou spray graisse silicone.

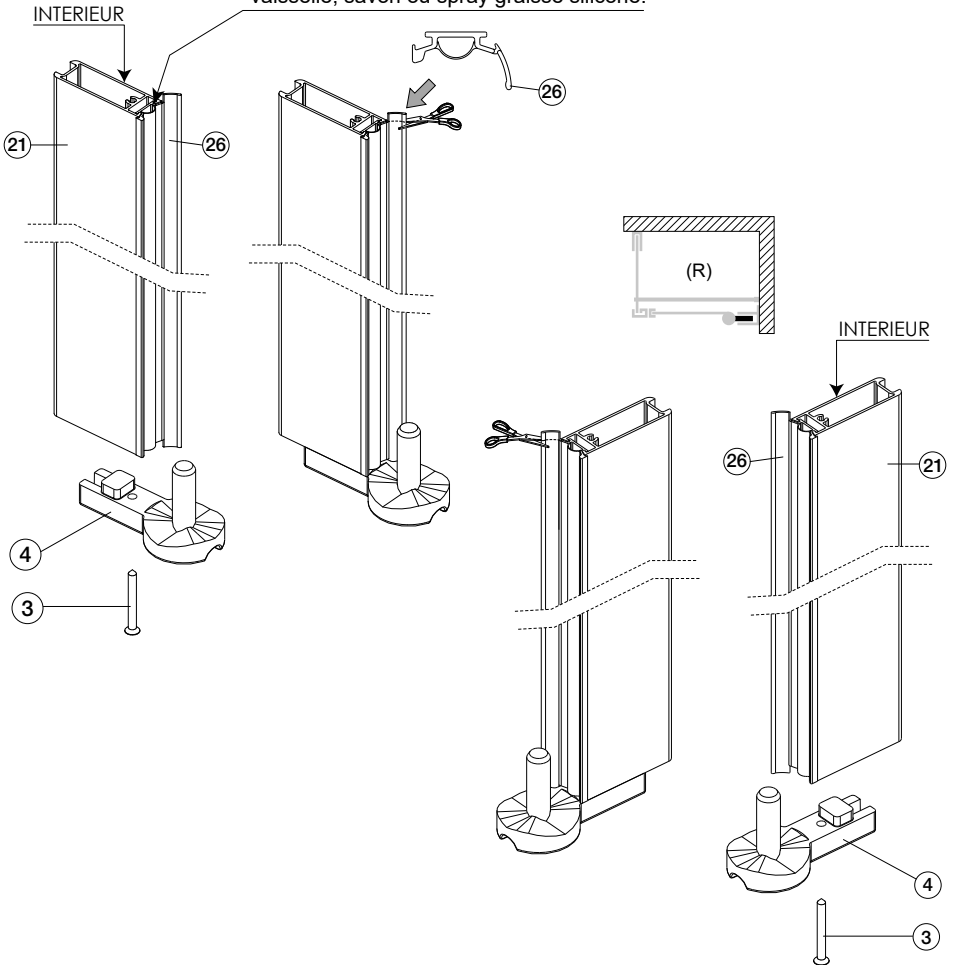

A4

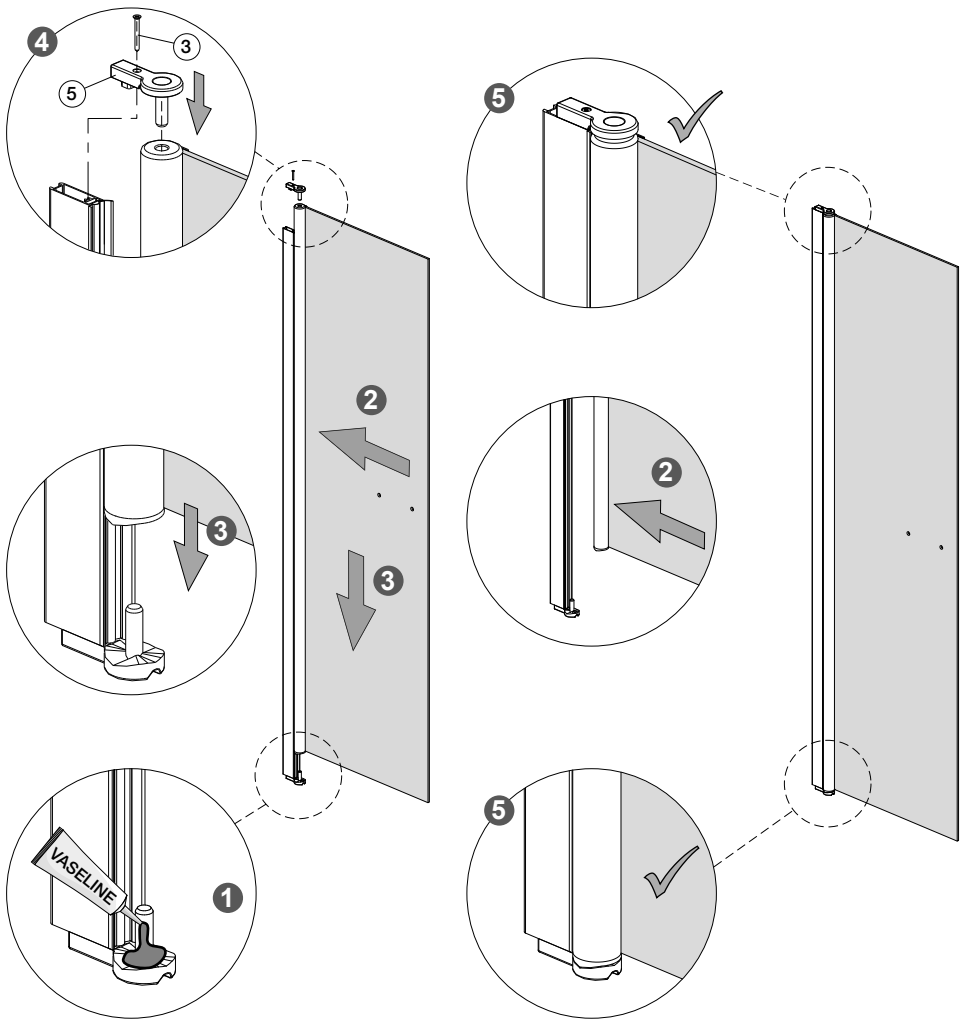
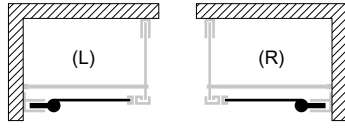



A5

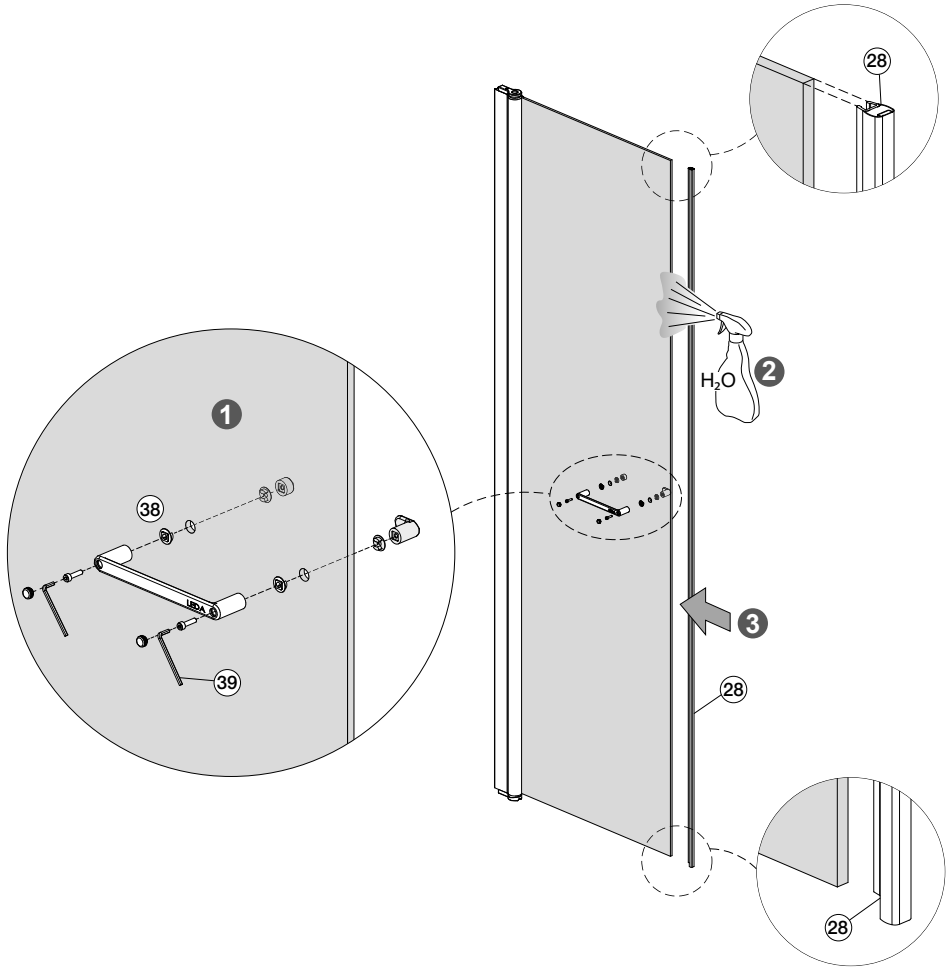
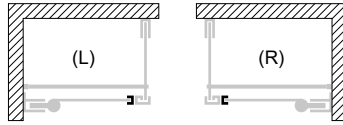

A6

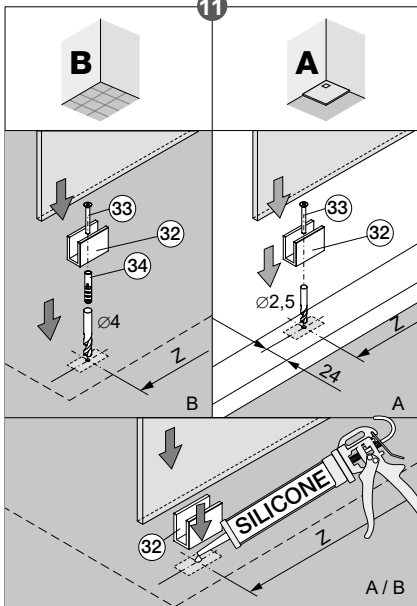
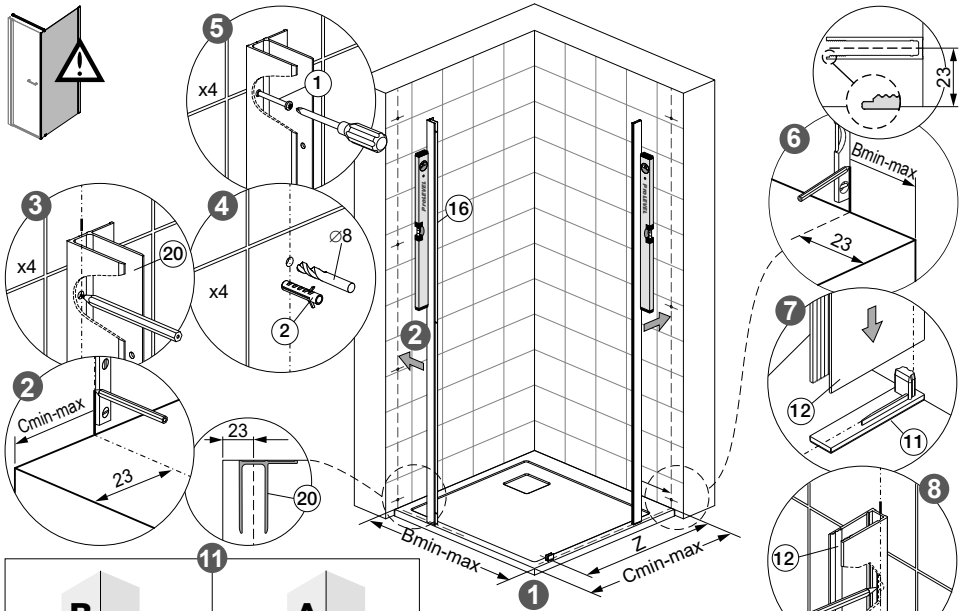

1			
	Cmin-max [mm]	Z [mm]	
	Paroi fixe-70	670-700	580
	Paroi fixe-75	720-750	630
	Paroi fixe-80	770-800	680
	Paroi fixe-90	870-900	780
	Paroi fixe-100	970-1000	880

1		
	Bmin-max [mm]	
	Porte pivotante-70	670-700
	Porte pivotante-80	770-800
	Porte pivotante-90	870-900

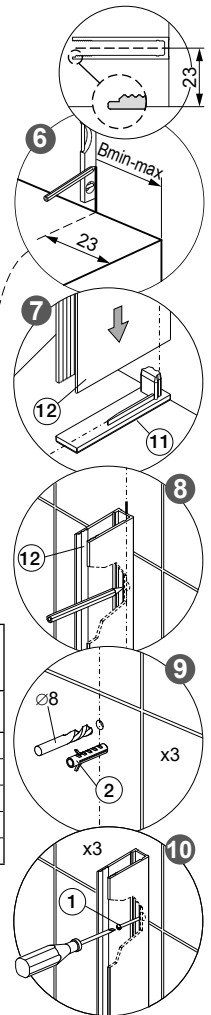

A7

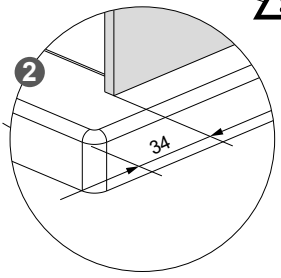
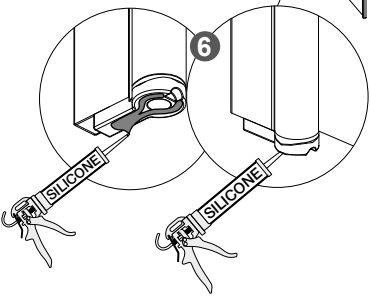
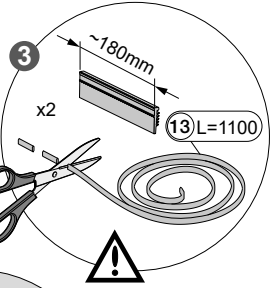
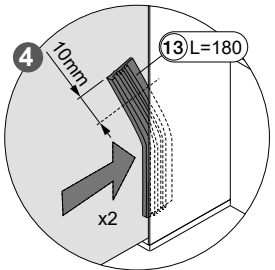
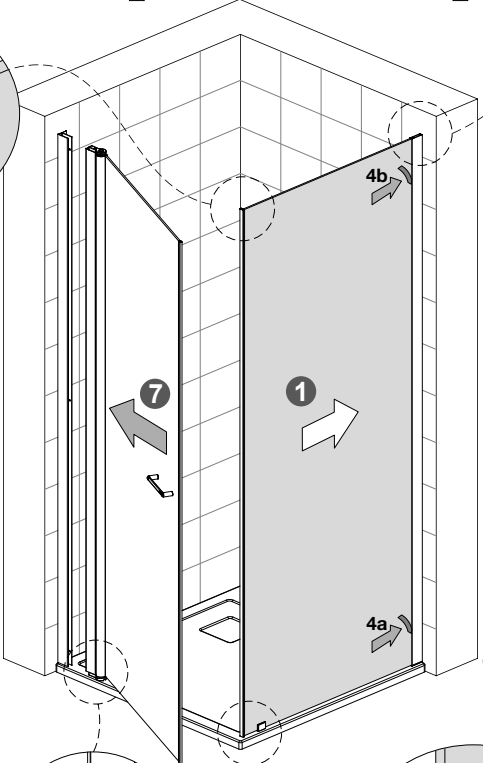
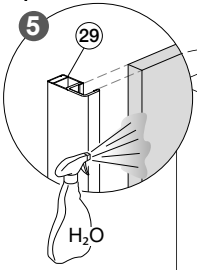
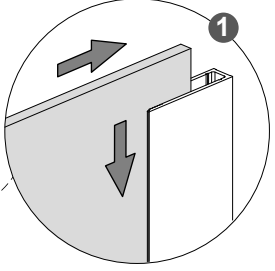
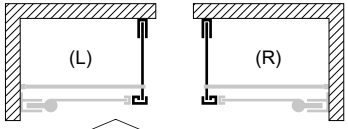
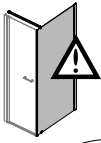

A8

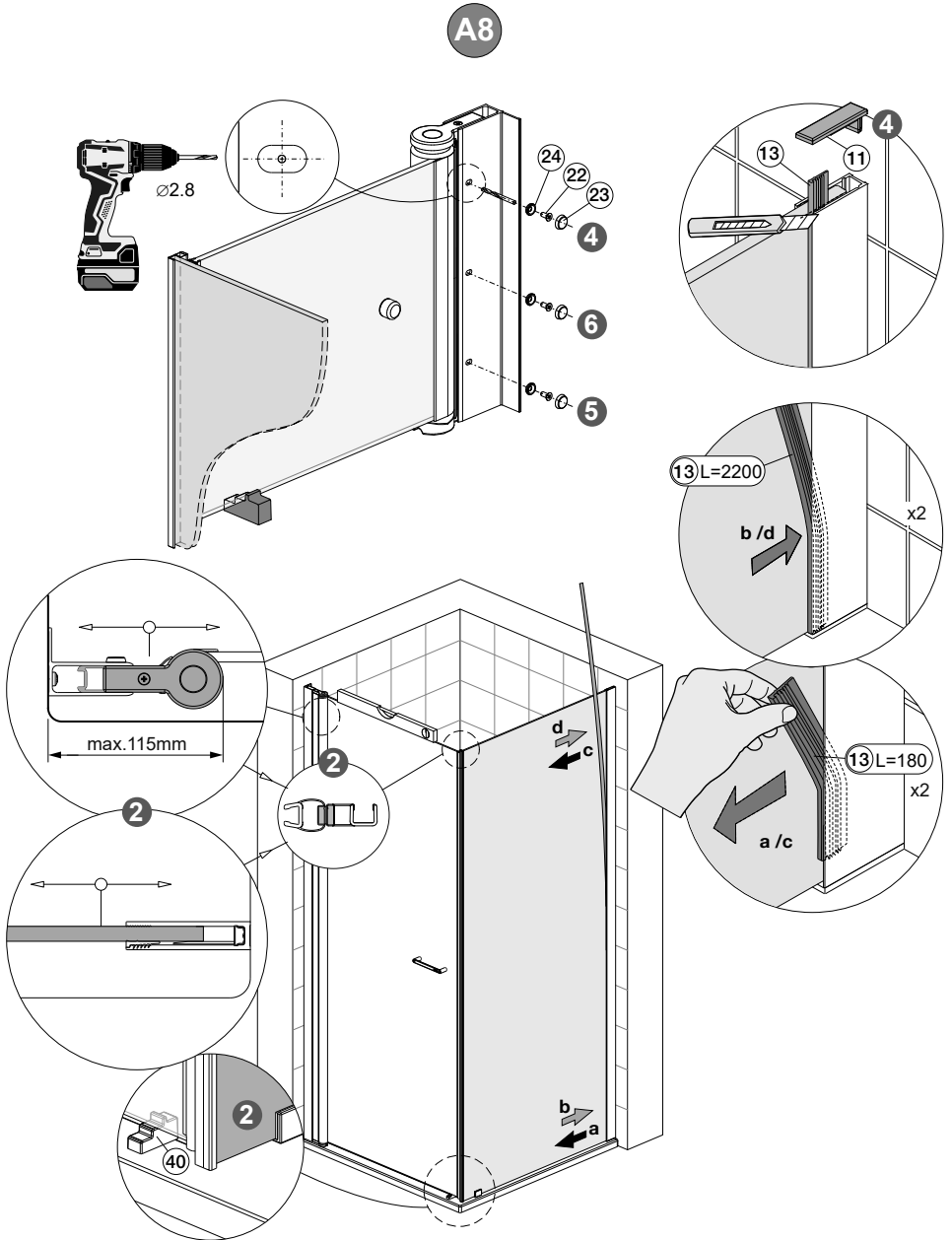

A9

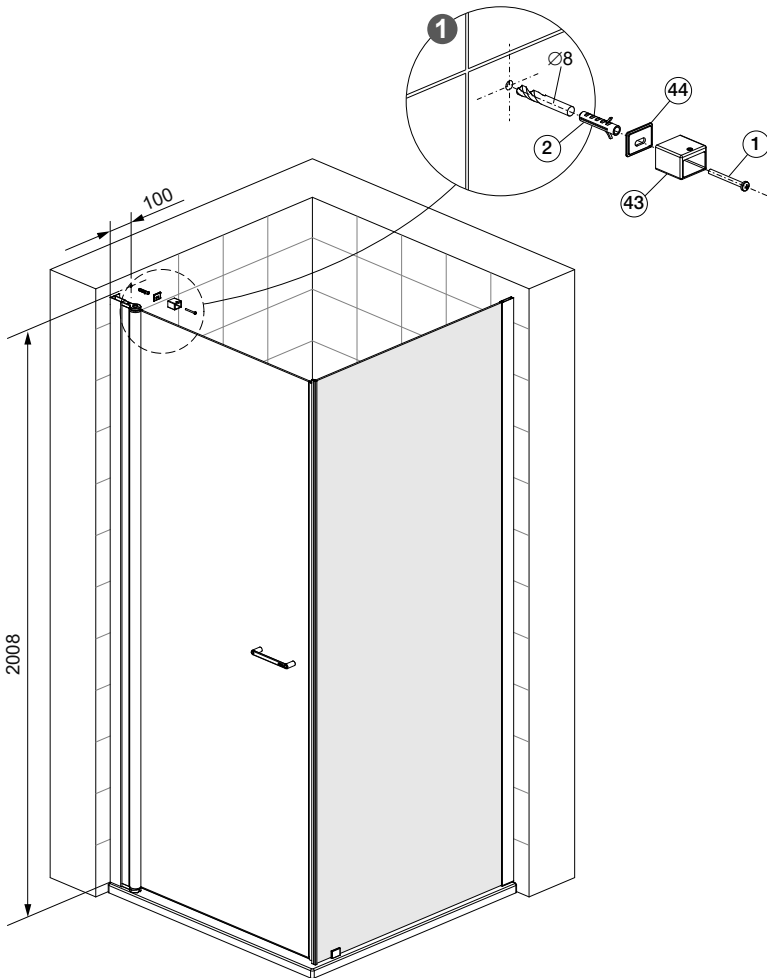
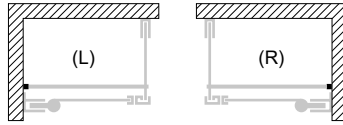

A10

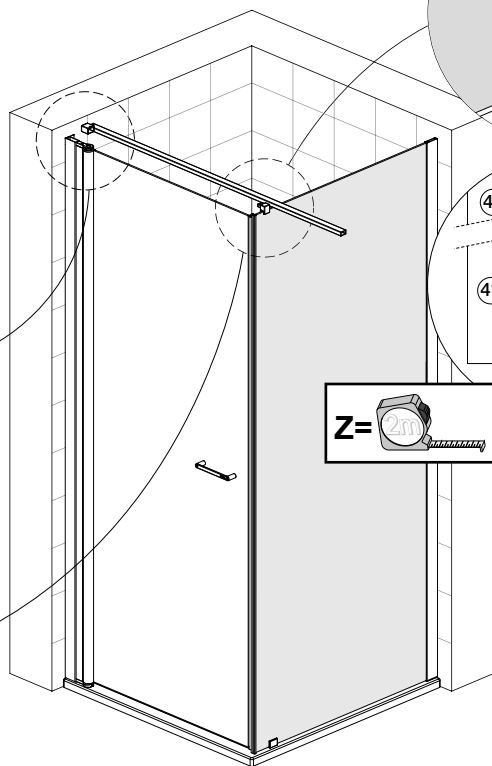
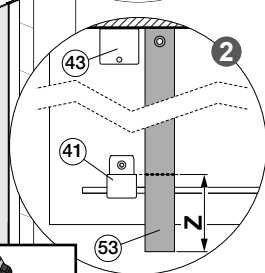
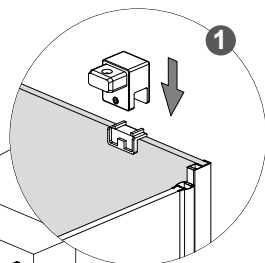
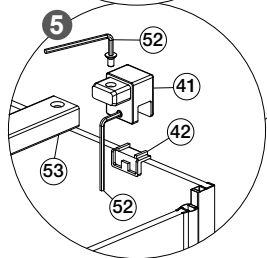
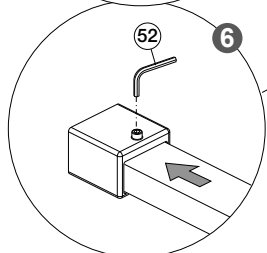
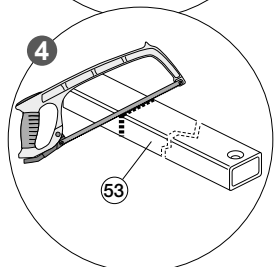
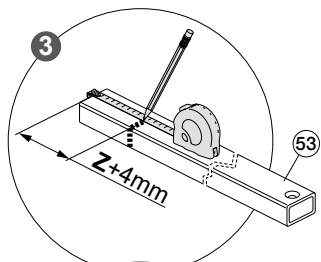
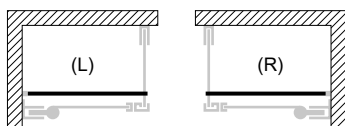

A11

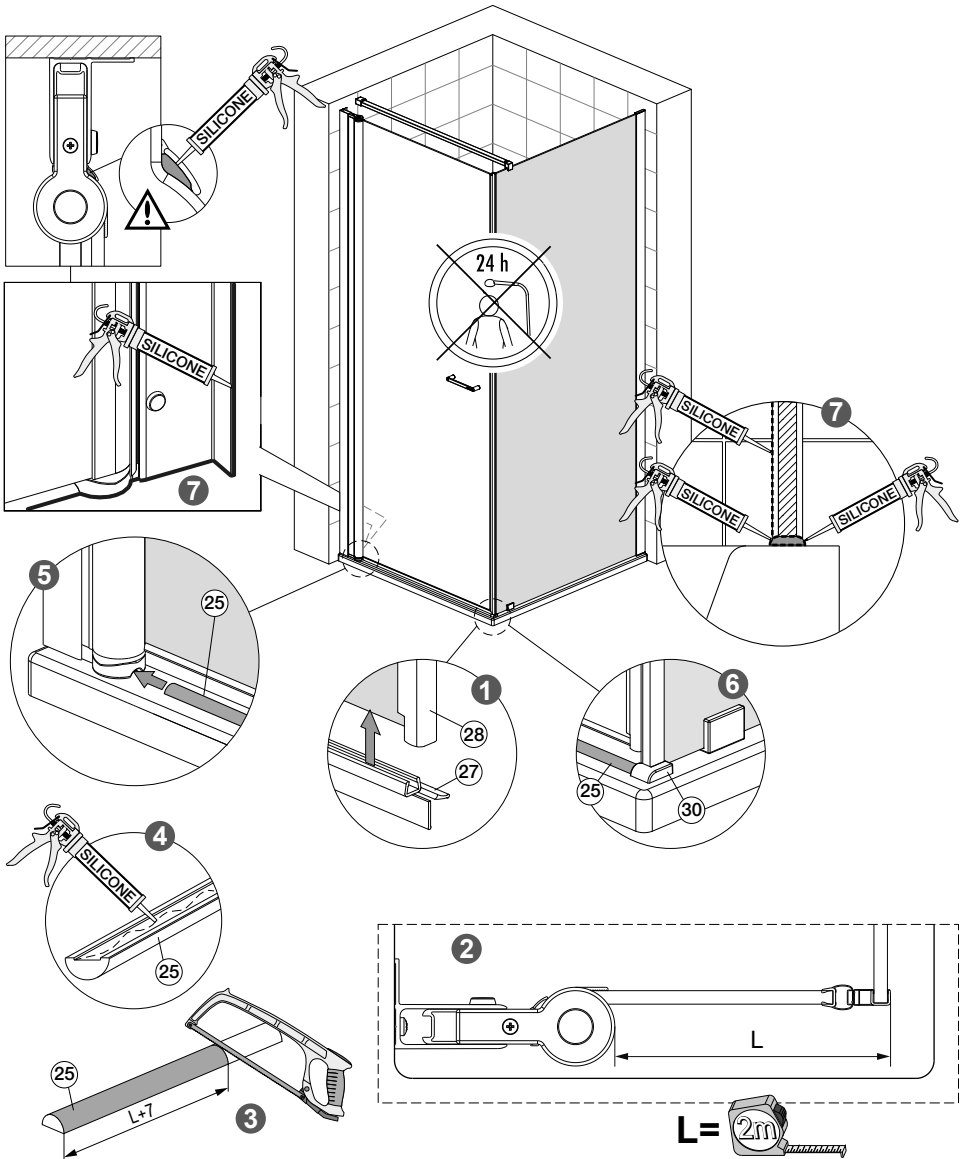

B2

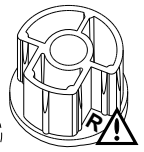
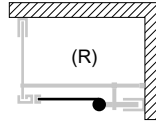
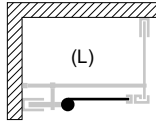
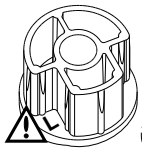

L

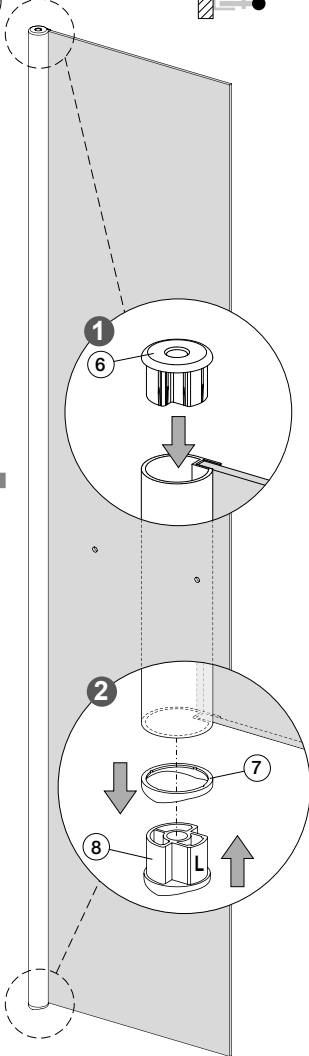

R

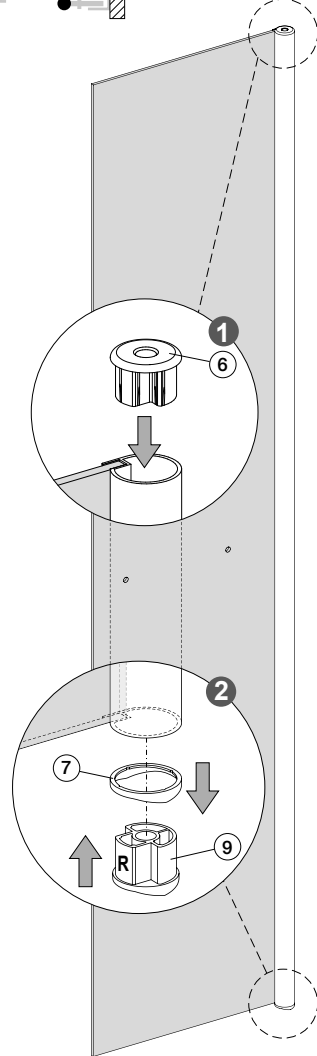



**B3**

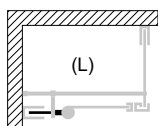

pour faciliter le coulissement mettre du liquide vaisselle, savon ou spray graisse silicone.

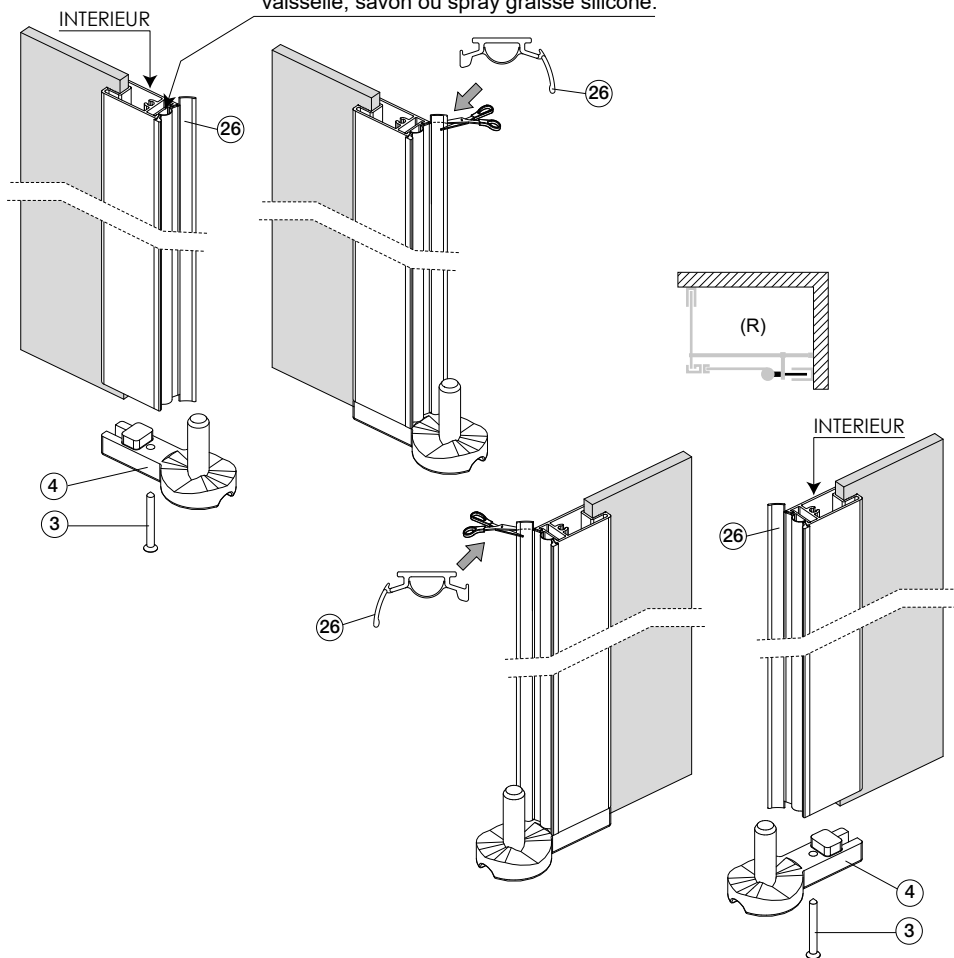

B4

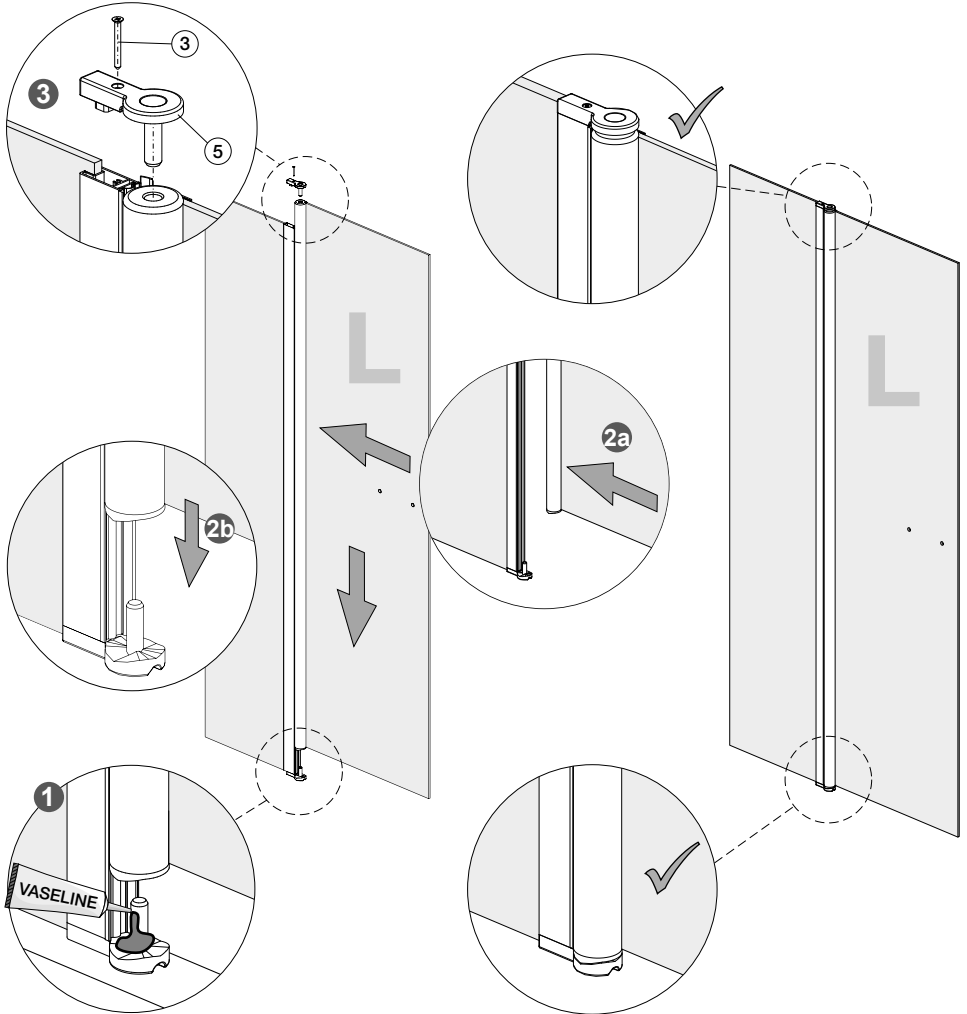
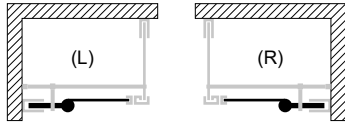

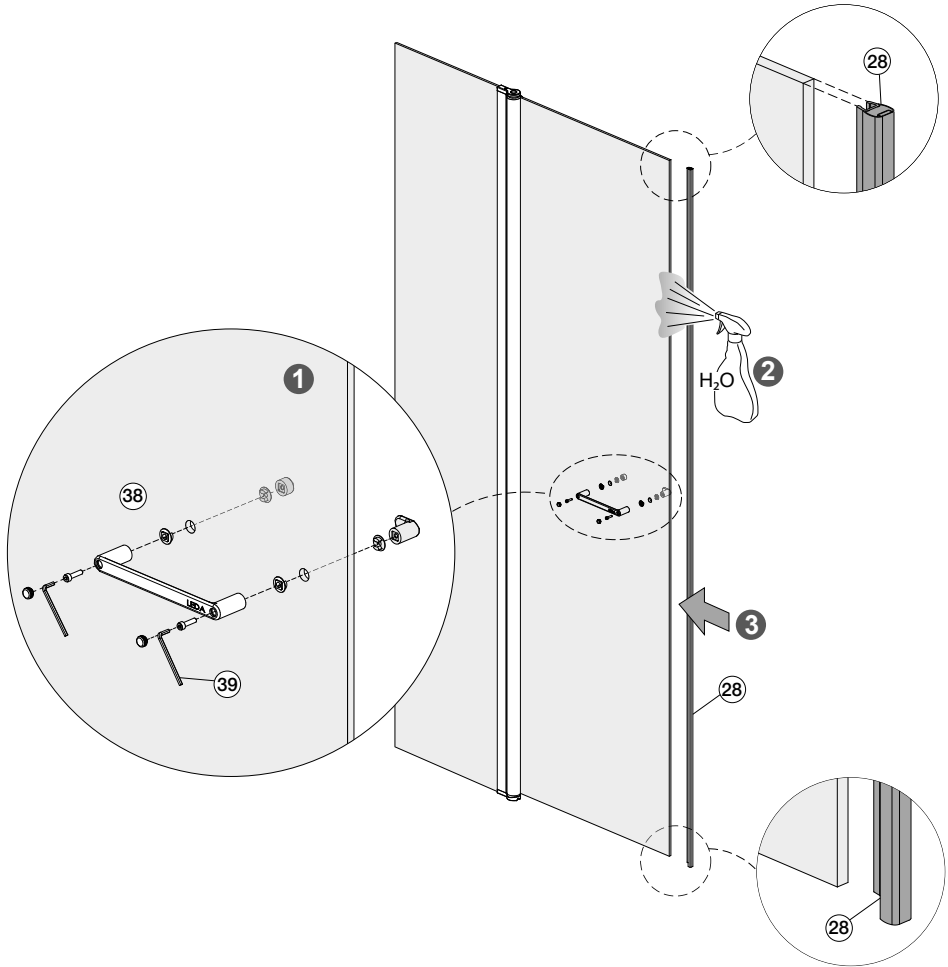
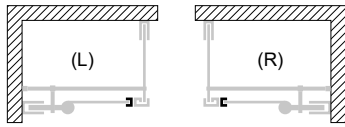

**B5**

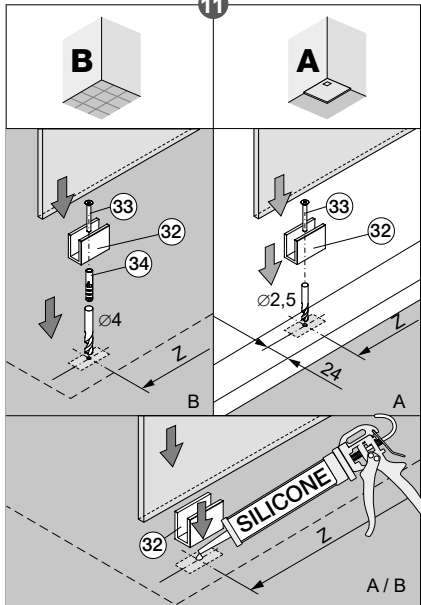
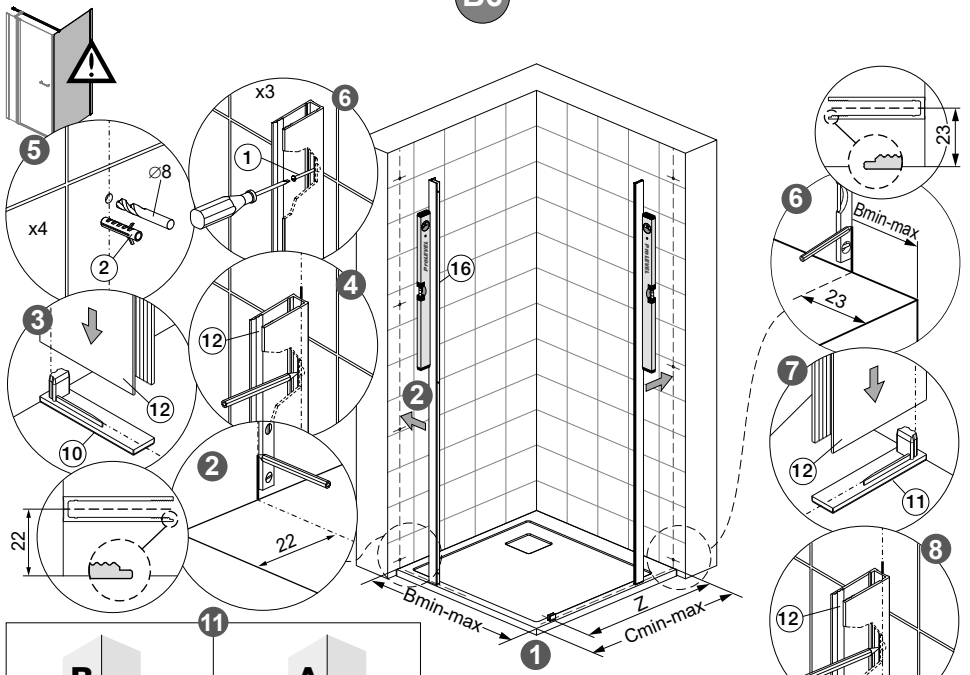

**B6**

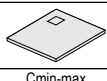

1			
	Cmin-max [mm]	Z [mm]	
	Paroi fixe-70	670-700	580
	Paroi fixe-75	720-750	630
	Paroi fixe-80	770-800	680
	Paroi fixe-90	870-900	780
	Paroi fixe-100	970-1000	880

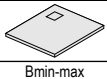
1		
	Bmin-max [mm]	
	Porte pivotante avec partie fixe-100	970-1000
	Porte pivotante avec partie fixe-110	1070-1100
	Porte pivotante avec partie fixe-120	1170-1200

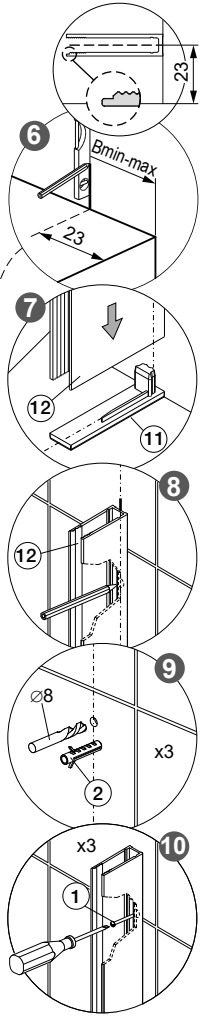

**B7**

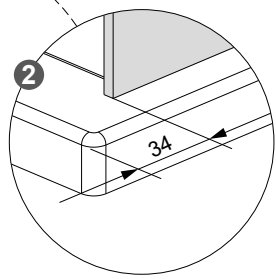
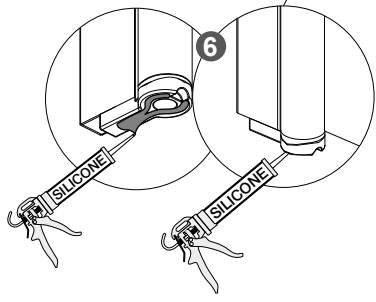
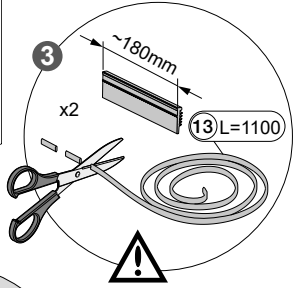
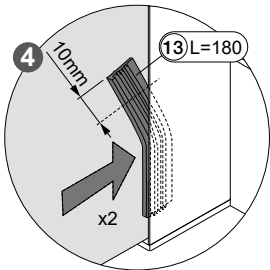
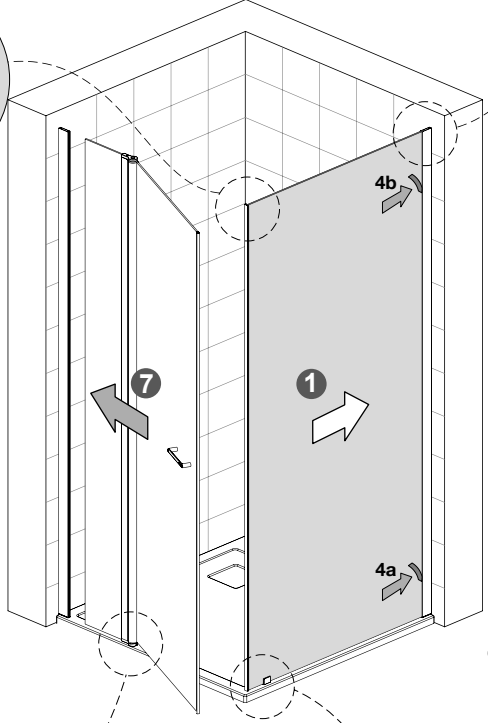
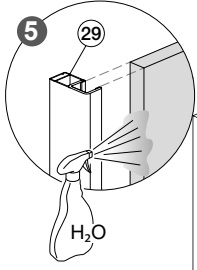
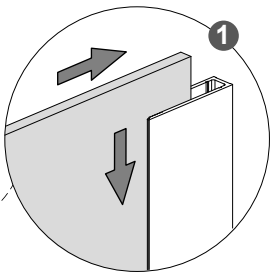
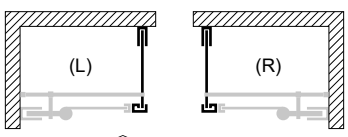
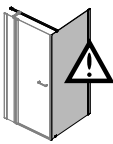

B8

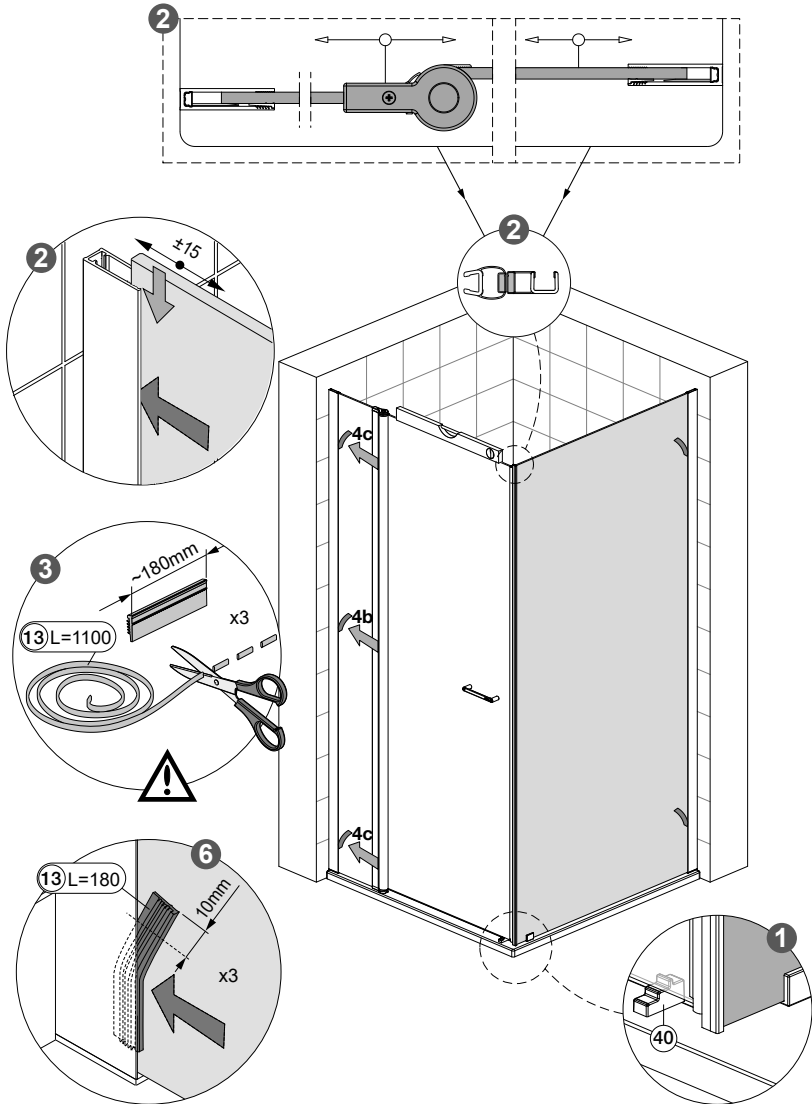

B9

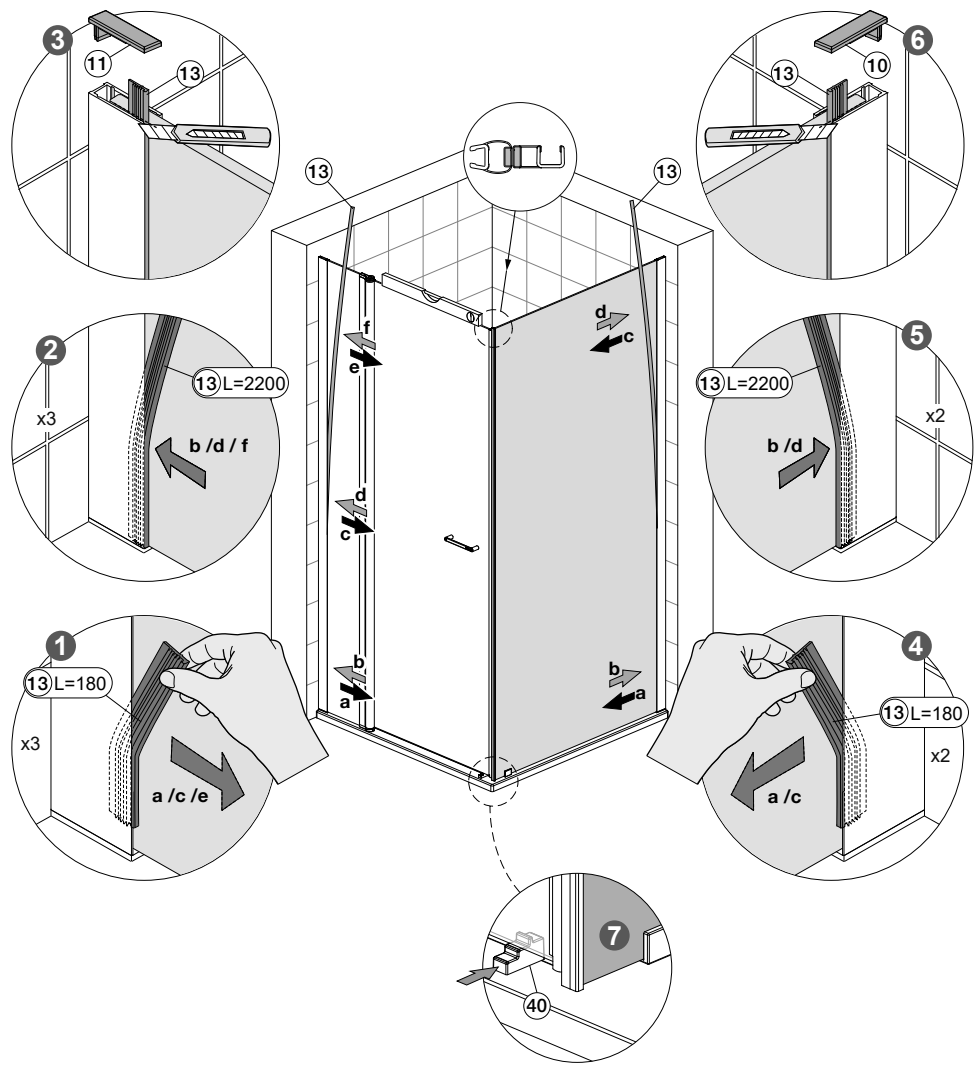

B10

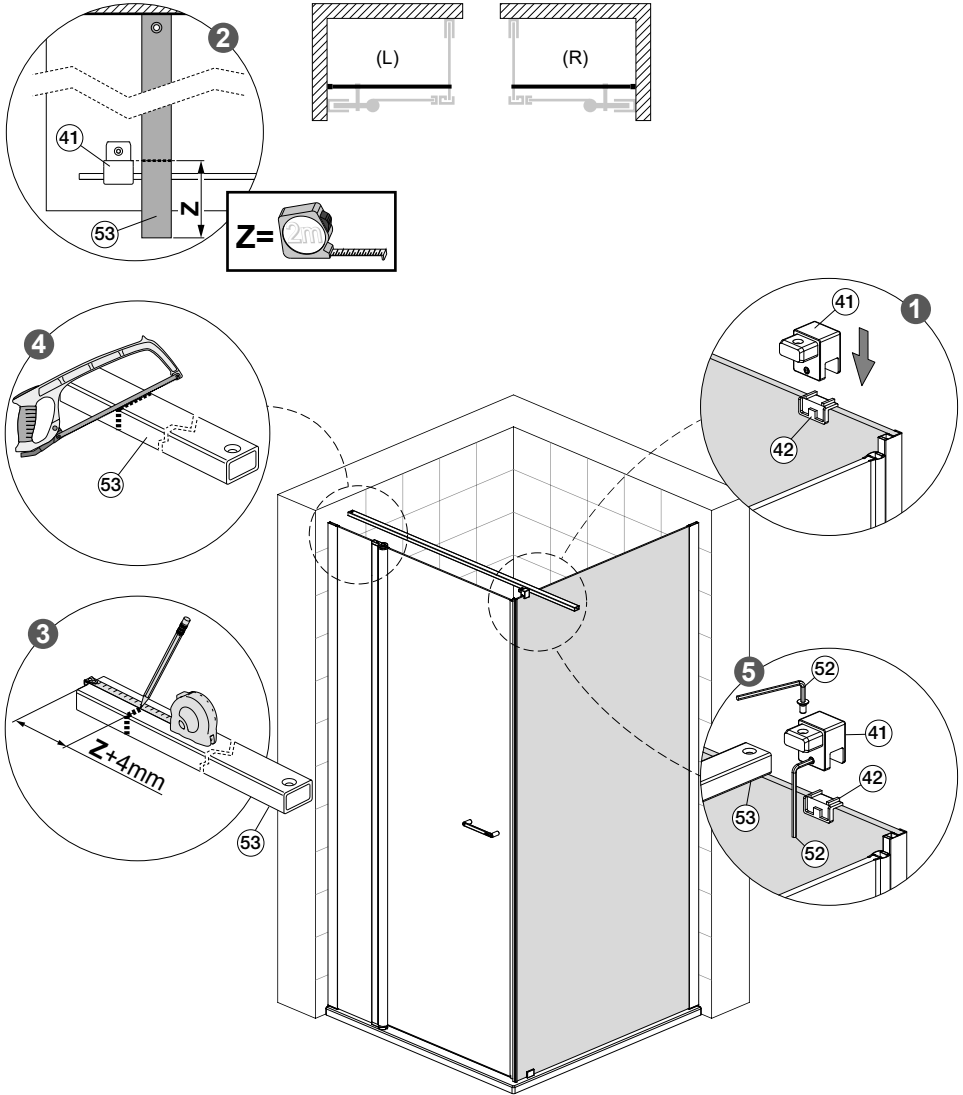



B11

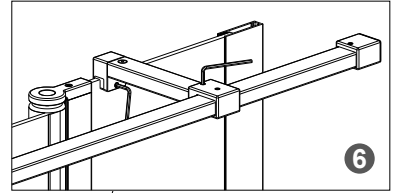
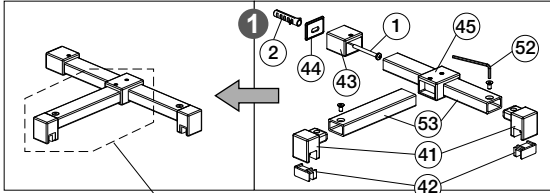
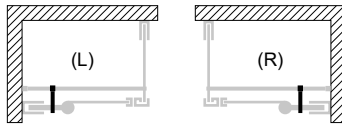

**A COMMANDER**  
Ref. L13AY0103  
L13AY0105 (NOIR)

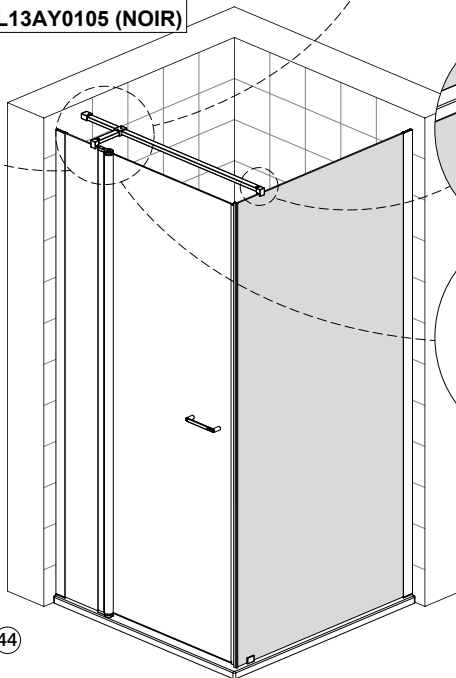
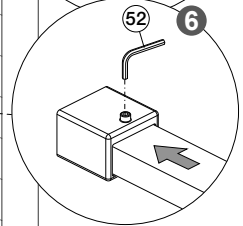
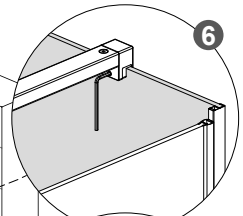
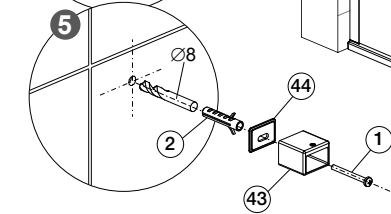
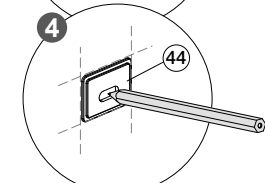
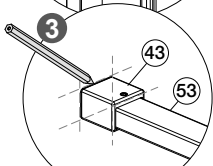
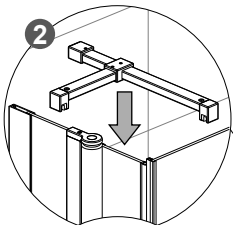

B12

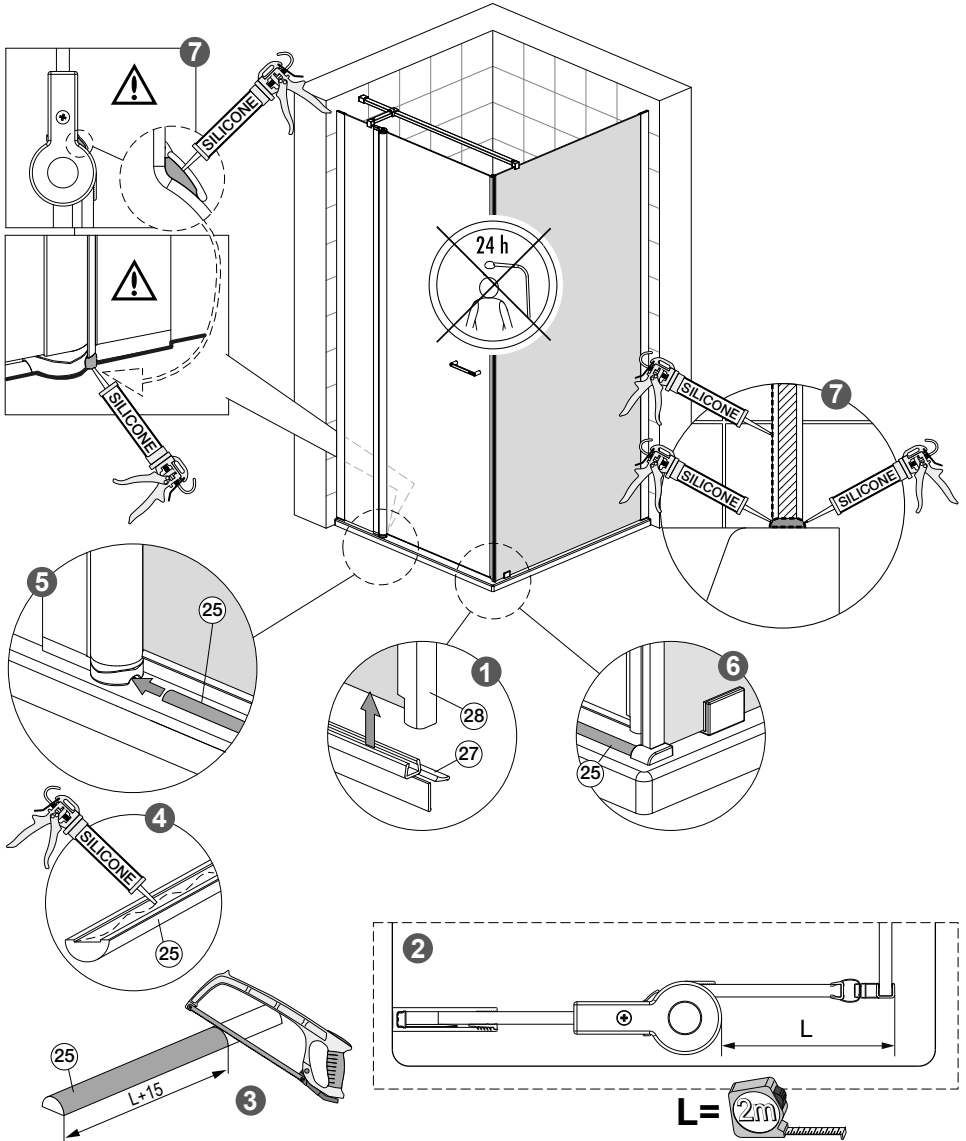

# PIÈCES DE RECHANGE / ONDERDELEN

Consulter votre revendeur pour toute commande de pièces détachées / Raadpleeg uw verdeler voor elke bestelling van onderdelen

## PAROI FIXE POUR MONTAGE AVEC PORTE

**A COMMANDER**  
Ref. L13AY0103  
L13AY0105

C2383

C2649

S1159	(70)
S1160	(75)
S1161	(80)
S1162	(90)
S1163	(100)

C2651

C2672

C2650

C2059

C2649

Ref	Qté
C1539	1
C1540	1
C2059	1
C2383	1
C2649	1
C2650	1
C2651	1
C2672	1
C2695	1
S1159	1
S1160	1
S1161	1
S1162	1
S1163	1
L13AY0103	1
L13AY0105	1

C1539	C1540	C2695
P	L	

## TRAITEMENT GLASS PROTECT

Le revêtement Glass Protect est un traitement du verre qui facilite l'entretien des parois vitrées en limitant les dépôts de calcaire, de graisse et de saleté. Le traitement rend la surface du verre hydrophobe et oléophobe. Ainsi, les liquides ou substances aqueux et huileux ou gras sont repoussés et glissent à la surface sans laisser de traces. Le verre a donc des propriétés de déperlance à l'eau, ainsi qu'aux substances grasses, et de ce fait présente des caractéristiques anti calcaires.

Le revêtement Glass Protect est si fin qu'il ne se voit pas à l'oeil nu, il ne modifie pas la transparence du verre : le seul effet visible révélant la présence de ce revêtement, c'est la formation de grosses gouttes d'eau qui glissent à la surface de la paroi et non la diffusion uniforme de milliers de gouttelettes d'eau qui s'accrochent et s'étalent sur la paroi.

A la différence des verres non traités, les verres traités Glass Protect vont être beaucoup plus faciles à nettoyer. **Cela ne signifie pas pour autant que les verres traités Glass Protect ne doivent pas être nettoyés.** Il peut rester des résidus visibles sur le verre après l'utilisation de la douche, notamment de savon. Ces résidus seront plus ou moins importants, et les particules se détacheront plus facilement.

Dans ce cas-là, afin d'assurer la longévité du traitement des parois de douche, il faut absolument respecter les conseils d'entretien et éviter d'utiliser :

- des poudres et des crèmes abrasives
- des nettoyeurs alcalins
- des nettoyeurs caustiques
- des produits acides
- des nettoyeurs désinfectants
- des nettoyeurs vapeur

Ces produits agressifs ne sont pas utiles puisque l'entretien s'effectue très facilement avec des produits doux comme les nettoyeurs neutres qui lavent mais n'attaquent pas le revêtement protecteur des parois de douche.

## **ENTRETIEN**

- Il est possible que le traitement anti-calcaire laisse des traces sur les vitrages, nous vous conseillons de nettoyer ceux-ci après l'installation des parois à l'aide d'un chiffon doux et sec.

- NE PAS UTILISER DE PRODUITS ABRASIFS OU SOLVANTS.

# LEDA

ZA du bois Gasseau  
CS 80004 SAMOREAU

77215 AVON CEDEX France

Tél. : 01 60 71 66 41 - Fax : 01 60 71 66 49 - sav@leda.tm.fr